

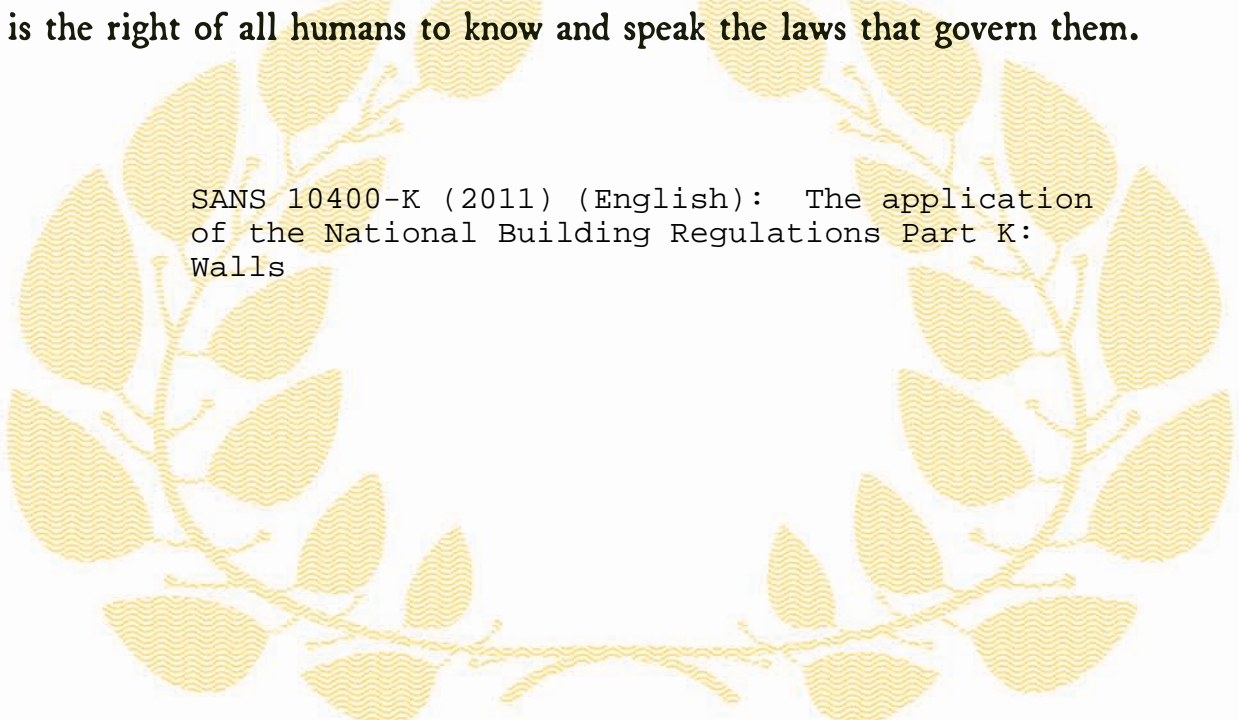

# *Republic of South Africa*

## ✎ EDICT OF GOVERNMENT ✎

In order to promote public education and public safety, equal justice for all, a better informed citizenry, the rule of law, world trade and world peace, this legal document is hereby made available on a noncommercial basis, as it is the right of all humans to know and speak the laws that govern them.



SANS 10400-K (2011) (English): The application  
of the National Building Regulations Part K:  
Walls



BLANK PAGE



ISBN 978-0-626-25193-2

**SANS 10400-K:2011**

Edition 3

# **SOUTH AFRICAN NATIONAL STANDARD**

## **The application of the National Building Regulations**

### **Part K: Walls**

---

Published by SABS Standards Division  
1 Dr Lategan Road Groenkloof ☒ Private Bag X191 Pretoria 0001  
Tel: +27 12 428 7911 Fax: +27 12 344 1568

[www.sabs.co.za](http://www.sabs.co.za)

© SABS

**SABS**

---

## **SANS 10400-K:2011**

Edition 3

### **Table of changes**

<b>Change No.</b>	<b>Date</b>	<b>Scope</b>

## **Acknowledgement**

The SABS Standards Division wishes to acknowledge the work of the South African Institution of Civil Engineering and the Home Builders Registration Council in updating this document.

## **Foreword**

This South African standard was approved by National Committee SABS TC 59, *Construction standards*, in accordance with procedures of the SABS Standards Division, in compliance with annex 3 of the WTO/TBT agreement.

This document was published in March 2011.

This document supersedes the corresponding parts of SABS 0400:1990 (first revision).

Compliance with the requirements of this document will be deemed to be compliance with the requirements of part K of the National Building Regulations, issued in terms of the National Building Regulations and Building Standards Act, 1977 (Act No. 103 of 1977).

SANS 10400 consists of the following parts, under the general title *The application of the National Building Regulations*:

*Part A: General principles and requirements.*

*Part B: Structural design.*

*Part C: Dimensions.*

*Part D: Public safety.*

*Part F: Site operations.*

*Part G: Excavations.*

*Part H: Foundations.*

*Part J: Floors.*

*Part K: Walls.*

*Part L: Roofs.*

*Part M: Stairways.*

*Part N: Glazing.*

*Part O: Lighting and ventilation.*

**Foreword** *(concluded)*

*Part P: Drainage.*

*Part Q: Non-water-borne means of sanitary disposal.*

*Part R: Stormwater disposal.*

*Part S: Facilities for persons with disabilities.*

*Part T: Fire protection.*

*Part V: Space heating.*

*Part W: Fire installation.*

This document should be read in conjunction with SANS 10400-A.

Annex C forms an integral part of this document. Annexes A and B are for information only.

# SANS 10400-K:2011

Edition 3

## Contents

	Page
Acknowledgement	
Foreword	
<b>1</b> Scope .....	3
<b>2</b> Normative references .....	3
<b>3</b> Definitions .....	4
<b>4</b> Requirements .....	9
<b>4.1</b> General .....	9
<b>4.2</b> Masonry walls .....	9
<b>4.2.1</b> General .....	9
<b>4.2.2</b> Masonry walling in single-storey and double-storey buildings .....	12
<b>4.2.3</b> Infill masonry panels in framed buildings.....	14
<b>4.2.4</b> Free-standing boundary, garden and retaining walls .....	42
<b>4.2.5</b> Balustrade and parapet walls .....	46
<b>4.2.6</b> Control joints.....	47
<b>4.2.7</b> Articulation joints.....	52
<b>4.2.8</b> Corbelling.....	52
<b>4.2.9</b> Lintels.....	56
<b>4.2.10</b> Masonry arches .....	72
<b>4.2.11</b> Roof fixing.....	72
<b>4.3</b> Timber-framed walls.....	75
<b>4.4</b> Fixing of roofs to concrete elements.....	76
<b>4.5</b> Water penetration.....	76
<b>4.5.1</b> Condensation.....	76
<b>4.5.2</b> Rain penetration .....	77
<b>4.5.3</b> Rising damp.....	78
<b>4.6</b> Behaviour in fire .....	81
<b>Annex A</b> (informative) National Building Regulations – Part K: Walls .....	82
<b>Annex B</b> (informative) Design of lintels .....	83
<b>Annex C</b> (normative) Rain penetration tests for walls .....	89
<b>Bibliography</b> .....	93

## **The application of the National Building Regulations**

### **Part K:**

#### **Walls**

### **1 Scope**

This part of SANS 10400 provides deemed-to-satisfy requirements for compliance with part K (Walls) of the National Building Regulations.

NOTE Part K of the National Building Regulations, issued in terms of the National Building Regulations and Building Standards Act, 1977 (Act No. 103 of 1977), is reproduced in annex A.

### **2 Normative references**

The following referenced documents are indispensable for the application of this document. For dated references, only the edition cited applies. For undated references, the latest edition of the referenced document (including any amendments) applies. Information on currently valid national and international standards can be obtained from the SABS Standards Division.

SANS 121/ISO 1461, *Hot dip galvanized coatings on fabricated iron and steel articles – Specifications and test methods.*

SANS 248, *Bituminous damp-proof courses.*

SANS 298, *Mastic asphalt for damp-proof courses and tanking.*

SANS 935, *Hot-dip (galvanized) zinc coatings on steel wire.*

SANS 952-1, *Polymer film for damp-proofing and waterproofing in buildings – Part 1: Monofilament and co-extruded products.*

SANS 1504 (SABS 1504), *Prestressed concrete lintels.*

SANS 2001-CM1, *Construction works – Part CM1: Masonry walling.*

SANS 2001-EM1, *Construction works – Part EM1: Cement plaster.*

SANS 10005, *The preservative treatment of timber.*

SANS 10082, *Timber frame buildings.*

SANS 10177-2, *Fire testing of materials, components and elements used in buildings – Part 2: Fire resistance test for building elements.*

## **SANS 10400-K:2011**

Edition 3

SANS 10400-A:2010, *The application of the National Building Regulations – Part A: General principles and requirements.*

SANS 10400-B (SABS 0400-B), *The application of the National Building Regulations – Part B: Structural design.*

SANS 10400-H (SABS 0400-H), *The application of the National Building Regulations – Part H: Foundations.*

SANS 10400-T:2011, *The application of the National Building Regulations – Part T: Fire protection.*

### **3 Definitions**

For the purposes of this document, the definitions given in SANS 10400-A (some of which are repeated for convenience) and the following apply.

#### **3.1**

##### **adequate**

adequate

a) in the opinion of any local authority, or

b) in relation to any document issued by the council, in the opinion of the council

#### **3.2**

##### **Agrément certificate**

certificate that confirms fitness-for-purpose of a non-standardized product, material or component or the acceptability of the related non-standardized design and the conditions pertaining thereto (or both) issued by the Board of Agrément South Africa

#### **3.3**

##### **articulation joint**

joint in masonry provided at suitable locations and intervals, that takes cognizance of the lateral stability and structural integrity of individual panels, and that enables wall panels to move in harmony with their supports without developing significant damage

#### **3.4**

##### **balustrade wall**

wall that serves the purpose of a balustrade

#### **3.5**

##### **bed joint**

horizontal mortared joint between courses of masonry

#### **3.6**

##### **Board of Agrément South Africa**

body that operates under the delegation of authority of the Minister of Public Works

#### **3.7**

##### **bond block**

masonry unit which is manufactured or modified on site to accommodate horizontal reinforcement within the depth of the unit

#### **3.8**

##### **brickforce**

light, welded steel fabric that comprises two hard-drawn wires of diameter not less than 2,8 mm and



not more than 3,55 mm, held apart by either perpendicular (ladder-type) or diagonal (truss-type) cross wires (see figure 1)

NOTE Ladder-type brickforce usually has a main wire diameter that does not exceed 3,15 mm and is supplied in rolls. Truss-type brickforce usually has a diameter of 3,55 mm and is supplied flat.

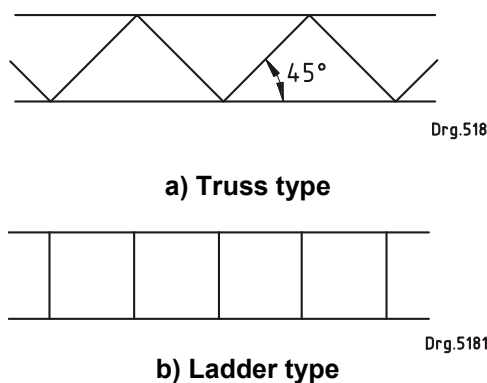

**Figure 1 — Brickforce types**

### **3.9**

#### **category 1 building**

building which

- a) is designated as being of class A3, A4, F2, G1, H2, H3, or H4 occupancy (see Regulation **A20** in SANS 10400-A),
- b) has no basements,
- c) has a maximum length of 6,0 m between intersecting walls or members providing lateral support, and
- d) has a floor area that does not exceed 80 m<sup>2</sup>

NOTE 1 Table C.1 in SANS 10400-A:2010 outlines the difference in performance between category 1 buildings and other buildings that have the same occupancy designation in respect of a number of building attributes.

NOTE 2 A building may be classified as a category 1 building for the purposes of one or more parts of SANS 10400. Additional limitations may accordingly be imposed on category 1 buildings. For example, a category 1 building in terms of SANS 10400-T (Fire protection) will be restricted to a single storey.

NOTE 3 Fire requirements for category 1 buildings are based on occupants escaping quickly from buildings. The design population for occupancies as set out in table 2 of part A of the Regulations (see SANS 10400-A) should therefore not be exceeded.

### **3.10**

#### **cavity**

void in a masonry member formed by or between the individual masonry units that comprise that member

### **3.11**

#### **cavity wall**

wall that consists of two parallel walls (called leaves) of either solid or hollow units, that are built side by side and tied to each other with wall ties so that there is a cavity of width at least 50 mm between the leaves

## SANS 10400-K:2011

Edition 3

### 3.12

#### **collar joint**

vertical longitudinal joint between leaves of masonry, filled with mortar or infill concrete (see figure 2)

### 3.13

#### **collar-jointed wall**

wall that comprises parallel single-leaf walls with a space between them that does not exceed 25 mm, solidly filled with mortar and tied together with wall ties (see figure 2)

### 3.14

#### **control joint**

movement joint

joint designed to permit relative movement of sections of a masonry structure or wall to occur without impairing the functional integrity of the masonry structure or wall

### 3.15

#### **core**

void within the cross section of a hollow masonry unit

### 3.16

#### **damp-proof**

proof against the transmission of moisture in liquid or vapour form

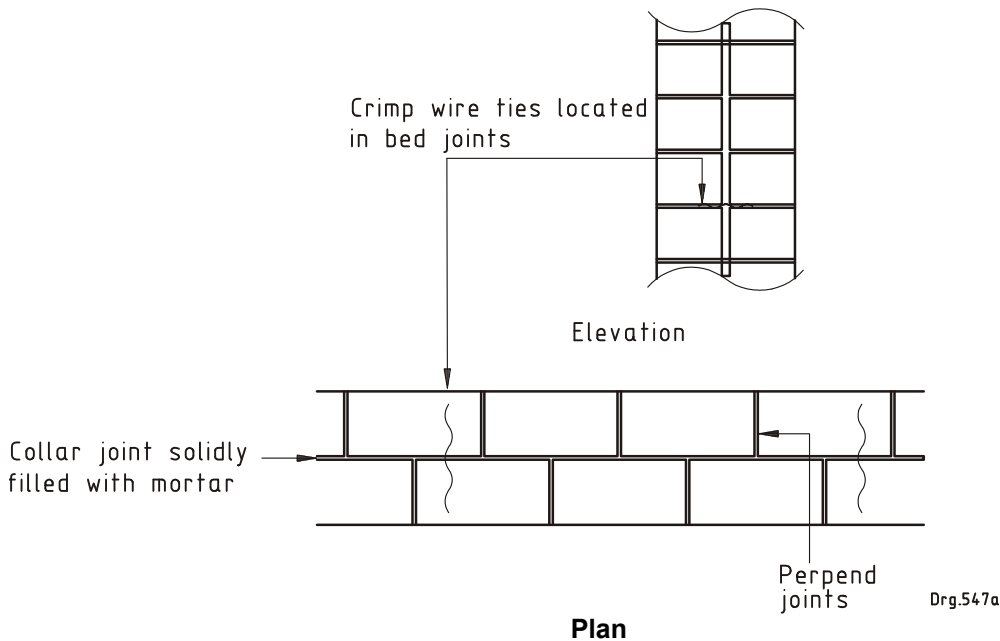

Figure 2 — Collar-jointed walls

### 3.17

#### **deemed-to-satisfy requirement**

non-mandatory requirement, the compliance with which ensures compliance with a functional regulation

### 3.18

#### **diaphragm wall**

wall that comprises two separate leaves and evenly spaced vertical columns (ribs) that join the leaves to form a hollow box section

**3.19**

**fire resistance**

shortest period for which a building element or building component complies with the requirements for stability, integrity and insulation when tested in accordance with SANS 10177-2

**3.20**

**foundation**

that part of a building which is in direct contact with, and is intended to transmit loads to, the ground

**3.21**

**foundation wall**

that portion of a wall between the foundation and the lowest floor above such foundation

**3.22**

**free-standing wall**

wall (that is not a retaining wall) without lateral support

**3.23**

**functional regulation**

regulation that sets out in qualitative terms what is required of a building or building element or building component in respect of a particular characteristic, without specifying the method of construction, dimensions or materials to be used

**3.24**

**garage**

enclosed area which is used or intended to be used for the parking, storing, servicing or repairing of motor vehicles

**3.25**

**grouted cavity wall**

cavity wall with the space between the leaves filled with infill concrete, and which may be reinforced

**3.26**

**infill concrete**

highly workable concrete placed in cores, cavities or pockets to produce grouted and reinforced masonry

**3.27**

**leaf**

continuous vertical section, which is one masonry unit width in thickness, of a wall

**3.28**

**lintel**

beam that spans an opening in a wall

**3.29**

**load**

value of a force corresponding to an action

**3.30**

**masonry**

assemblage of masonry units joined together with mortar to form a structure

**3.31**

**masonry unit**

rectangular unit that is intended for use in the construction of bonded masonry walling

## **SANS 10400-K:2011**

Edition 3

### **3.31.1**

#### **hollow masonry unit**

masonry unit that contains cores that exceed 25 %, but that do not exceed 60 %, of the gross volume of the unit

### **3.31.2**

#### **solid masonry unit**

masonry unit that either contains no cores, or contains cores that do not exceed 25 % of the gross volume of the unit

### **3.32**

#### **masonry wall**

assemblage of masonry units that are joined together with mortar or grout

### **3.33**

#### **mortar**

mixture of cementitious materials, sand (fine aggregate) and water, with or without chemical admixtures

### **3.34**

#### **parapet wall**

low wall at the edge of a balcony or roof or along the sides of a bridge

### **3.35**

#### **perpend joint**

joint (typically vertical) formed between adjacent masonry units laid in the same course

### **3.36**

#### **reinforced masonry**

masonry in which grouted or concreted cavities, cores or pockets or bed joints are reinforced with steel reinforcement to strengthen the masonry

### **3.37**

#### **retaining wall**

wall intended to resist the lateral displacement of materials

### **3.38**

#### **rod reinforcement**

bed joint reinforcement in masonry that comprises hard-drawn wires that have a diameter of not less than 4,0 mm and not greater than 6,0 mm, and which are pre-straightened at the point of manufacture

### **3.39**

#### **shell bedding**

bedding in mortar of the plan area of the face shells, but not the webs, of hollow masonry units during laying (see figure 3)

### **3.40**

#### **single-leaf wall**

wall of masonry units laid to overlap in one or more directions and set solidly in mortar

### **3.41**

#### **stability**

ability of a structure to maintain equilibrium and to resist displacement or overbalancing

### **3.42**

#### **strength**

capability of a body to resist the loads applied to it

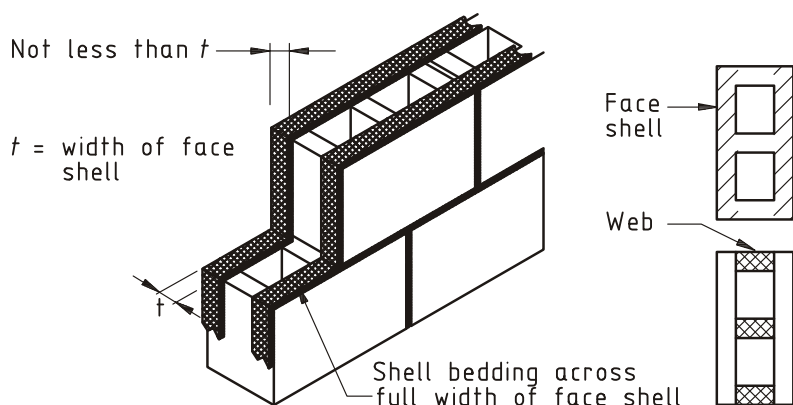

Drg.547b

**Figure 3 — Shell bedding**

**3.43**

**structural**

relating to or forming part of any structural system

**3.44**

**suitable**

capable of fulfilling or having fulfilled the intended function, or fit for its intended purpose

**3.45**

**vapour barrier**

impervious barrier that prevents the passage of water vapour through building components

## 4 Requirements

### 4.1 General

The functional regulations **K1** to **K4** contained in part K of the National Building Regulations (see annex A) shall be deemed to be satisfied where a wall complies with the requirements of

- a) SANS 10400-B, SANS 10400-T and 4.4; or
- b) 4.2, 4.4, 4.5 and 4.6; or
- c) 4.3, 4.4, 4.5 and 4.6.

NOTE The masonry walling panels have been sized by calculations using the approach provided in appendix G of the Joint Structural Division of the South African Institution of Civil Engineering and the Institution of Structural Engineers' *Code of practice for foundations and superstructures for single-storey residential buildings of masonry construction*, 1995.

### 4.2 Masonry walls

#### 4.2.1 General

**4.2.1.1** The requirements of 4.2 apply only to masonry walls that are not exposed to severe wind loadings at crests of steep hills, ridges and escarpments and, in case of

- a) single-storey buildings or the upper storey of double-storey buildings, where

## **SANS 10400-K:2011**

### Edition 3

- 1) the foundations for masonry walls comply with the requirements of SANS 10400-H and the supporting members comply with the requirements of SANS 10400-B;
  - 2) the span of roof trusses or rafters (or both) between supporting walls does not exceed
    - i) 6,0 m in respect of 90 mm and 110 mm single-leaf walls,
    - ii) 8,0 m in respect of 140 mm (or greater) single-leaf walls and all cavity and collar-jointed walls;
  - 3) the nominal height of masonry above the top of openings is not less than 0,4 m;
  - 4) the average compressive strength of hollow and solid masonry units is not less than 3,0 MPa and 4,0 MPa, respectively;
  - 5) the mortar is class II that complies with the requirements of SANS 2001-CM1;
  - 6) the mass of the roof covering, in roofs other than concrete slabs, does not exceed 80 kg/m<sup>2</sup>;
  - 7) the span of the concrete roof slabs between supporting walls does not exceed 6,0 m;
  - 8) concrete roof slabs are not thicker than 255 mm if of solid construction, or they are of the equivalent mass of such a solid slab if of voided construction;
  - 9) foundation walls are not thinner than the walls which they support; and
  - 10) the height of foundation walls does not exceed 1,5 m;
- b) the lower storey in a double-storey building, where
- 1) the imposed floor load does not exceed 3,0 kN/m<sup>2</sup>;
  - 2) the foundations for masonry walls comply with the requirements of SANS 10400-H and the supporting members comply with the requirements of SANS 10400-B;
  - 3) the height measured from the ground floor to the top of an external gable does not exceed 8,0 m;
  - 4) the storey height measured from floor to wall plate level or to the underside of the first floor does not exceed 3,0 m;
  - 5) the span of concrete floor slabs between supporting walls does not exceed 6,0 m;
  - 6) the floor slabs are not thicker than 255 mm if of solid construction, or they are of the equivalent mass of such a solid slab if of voided construction;
  - 7) the average compressive strength of the hollow and solid masonry units is not less than 7,0 MPa and 10 MPa, respectively;
  - 8) the mortar is class II that complies with the requirements of SANS 2001-CM1;
  - 9) the walls supporting floor elements are of cavity construction or have a nominal thickness of not less than 140 mm; and
  - 10) the mass of the roof covering does not exceed 80 kg/m<sup>2</sup>;

**SANS 10400-K:2011**

Edition 3

- c) infill panels in concrete and steel-framed buildings of four storeys or less, where
- 1) the average compressive strength of hollow and solid masonry units is not less than 3,0 MPa and 4,0 MPa, respectively;
  - 2) the mortar is class II that complies with the requirements of SANS 2001-CM1;
  - 3) the walls are either of a cavity construction or have a nominal thickness of not less than 140 mm; and
  - 4) the nominal height of masonry above openings is not less than 0,4 m; and
  - 5) the storey height measured from floor to soffit of the floor above does not exceed 3,3 m; and
- d) free-standing, retaining, parapet and balustrade walls, where
- 1) the average compressive strength of hollow and solid masonry units is not less than 3,0 MPa and 5,0 MPa, respectively; and
  - 2) the mortar is class II that complies with the requirements of SANS 2001-CM1.

NOTE 1 In accordance with SANS 10400-B, the imposed load in the following occupancy classes and zones does not exceed 3,0 kN/m<sup>2</sup>:

- a) all rooms in a dwelling unit and a dwelling house, including corridors, stairs and lobbies to a dwelling house;
- b) bedrooms, wards, dormitories, private bathrooms and toilets in educational buildings, hospitals, hotels and other institutional occupancies;
- c) classrooms, lecture theatres, X-ray rooms and operating theatres;
- d) offices for general use and offices with data-processing and similar equipment;
- e) cafés and restaurants;
- f) dining rooms, dining halls, lounges, kitchens, communal bathrooms and toilets in educational buildings, hotels and offices;
- g) entertainment, light industrial and institutional occupancies; and
- h) corridors, stairs and lobbies to all buildings.

NOTE 2 The imposed load in the following areas exceeds 3,0 kN/m<sup>2</sup>:

- a) filing and storage areas to offices, institutional occupancies, and hotels;
- b) light laboratories;
- c) sales and display areas in retail shops and departmental stores;
- d) banking halls; and
- e) shelved areas to libraries.

**4.2.1.2** The construction of the walls shall be in accordance with the requirements of SANS 2001-CM1. Rod reinforcement shall comprise hard-drawn wires that have a proof stress of 485 MPa.

**4.2.1.3** Cavities in cavity walls shall not be less than 50 mm or more than 110 mm wide.

## **SANS 10400-K:2011**

Edition 3

### **4.2.1.4 Metal wall ties used in areas**

- a) between the coastline and an imaginary line 30 km inland,
- b) parallel with the coastline, or
- c) at the top of the escarpment or watershed of the first mountain range inland, if these are less than 30 km from the coastline,

shall have a minimum thickness of galvanizing of  $750 \text{ g/m}^2$  and in tidal splash zones shall be manufactured from stainless steel.

**4.2.1.5** In areas within 1 km from the coastline or shoreline of large expanses of salt water and within 3 km of industries that discharge atmospheric pollutants which are corrosive,

- a) brickforce shall be manufactured from pre-galvanized wire, and the galvanizing shall be in accordance with SANS 935 for a grade 2 coating; and
- b) rod reinforcement shall be galvanized in accordance with the requirements of SANS 935 for a grade 2 coating or SANS 121, as appropriate.

**4.2.1.6** In tidal and splash zones, brickforce and rod reinforcement shall be made of stainless steel wire.

**4.2.1.7** Lintels shall be provided above all window and door openings in accordance with the requirements of 4.2.9.

**4.2.1.8** Bed joint reinforcement shall be discontinuous across a control joint that is tied.

### **4.2.2 Masonry walling in single-storey and double-storey buildings**

**4.2.2.1** Masonry wall panels in single-storey and double-storey buildings shall have dimensions not greater than those derived from figures 4 and 5 and tables 1 to 6, subject to the maximum lengths of openings and the minimum distances between the faces of supports and openings and between successive openings being in accordance with figure 6 and table 7.

NOTE 1 The dimensions for panels with openings in tables 1, 2, 4 and 5 are only valid if lintels in accordance with the requirements of 4.2.9 are provided above all windows and openings.

NOTE 2 Occasionally, during the lifetime of a building, the positions of openings in walls are changed. For this reason, it is recommended that reinforcement be provided in a continuous band in external walls, particularly in the case of walls less than 190 mm thick, to form a lintel or "ring" beam.

**4.2.2.2** The distance between an opening and a free edge shall not be less than dimension  $b$  given in table 7. Where collar joints in collar-jointed walls are not fully mortared, such walls shall, for the purposes of 4.2.1.1, be treated as cavity walls. Panels incorporating full height doors or doors with fanlights shall be treated as panels supported on one side only and shall be sized in accordance with table 4 (wall with opening).

#### **EXAMPLE**

An owner wishes to build a single-storey building using 190 mm wide hollow masonry units.

The largest (and therefore critical) wall panel dimensions in the chosen layout are as follows:

- wall panel with no openings:  $7,0 \text{ m} \times 2,6 \text{ m}$
- wall panel with openings less than 15 %:  $6,2 \text{ m} \times 2,6 \text{ m}$



## SANS 10400-K:2011

Edition 3

- wall panel with openings greater than 15 %: 6,5 m × 2,6 m
- internal wall panels: 7,0 m × 2,6 m
- gable end panel (11° double-pitched roof) without openings: 6,0 m × 2,6 m

**Wall panel with no opening:** A 7,0 m × 2,6 m panel is within the limits for panel A (see columns 3 to 6 of table 1), namely 7,5 m × 2,7 m.

**Wall panel with openings less than 15 %:** The limiting dimensions for panel B of table 1 are 6,5 m × 2,4 m and 5,0 m × 4,6 m (see columns 7 to 10 of table 1).

By interpolating between tables, the maximum length of a 2,6 m high panel is

$$6,5 \text{ m} - (2,6 \text{ m} - 2,4 \text{ m}) / (4,6 \text{ m} - 2,4 \text{ m}) \times (6,5 \text{ m} - 5,0 \text{ m}) = 6,36 \text{ m}.$$

Thus a 6,2 m × 2,6 m panel is adequate.

**Wall panel with openings greater than 15 %:** The limiting dimensions for panel C of table 1 are 6,0 m × 2,7 m and 4,8 m × 4,4 m (see columns 11 to 14 of table 1).

A 6,5 m × 2,6 m panel does not comply with the requirements of this part of SANS 10400 as its length exceeds the maximum permissible length of 6,0 m. It can be made to comply with the requirements by reducing the length to 6,0 m or by providing truss-type reinforcement and a reinforced bond block in accordance with note 2 of table 1 since an 8,0 m × 4,0 m panel is permitted in respect of 190 mm solid masonry units (see columns 11 and 12 of table 1).

**Internal walls:** The maximum internal wall panel dimensions (for hollow units) as given in table 3 are 8,5 m and 4,6 m. The 7,0 m × 2,6 m panel is well within these limits.

**Gable end:** The maximum wall panel length (for hollow units) (11° roof pitch) for walls without openings as given in table 5 is 6,0 m. A 6,0 m × 2,6 m panel complies with the requirements.

The maximum base width of the triangular portion of the wall above eaves height permitted in terms of table 6 is 8,0 m for a roof that has an 11° roof pitch. The gable end dimensions are within this limit.

**4.2.2.3** Vertical supports, where required, shall extend to the top of the wall or, in the case of gable ends, to eaves level, and shall comprise intersecting walls which shall, with respect to figure 8,

- a) intersect the supported wall at an angle of between 60° and 120°;
- b) have a thickness of not less than 90 mm; and
- c) have a length projecting beyond the face of the unsupported wall of not less than the greater of
  - 1) for internal walls: 1/8<sup>th</sup> of the height of the wall and 1/10<sup>th</sup> of the wall length; and
  - 2) for external walls: 0,5 m and one-half the sum of adjacent panel lengths in the case of an intermediate support, and one-half the panel lengths for a corner support, as appropriate, divided by
    - i) for vertical supports of thickness  $\leq$  110 mm: 2,5
    - ii) for vertical supports of thickness  $\geq$  140 mm: 3,0.

**4.2.2.4** Where such vertical supports incorporate an opening, the length derived in accordance with 4.2.2.3(c) shall be extended by the length of such opening. Supports should generally extend the full height of the panel. A support on one side of a panel may extend for only 90 % of the height of the panel provided that the support on the opposite end of the panel extends the full height (see figure 8).

## **SANS 10400-K:2011**

Edition 3

**4.2.2.5** Walls supporting either concrete floors or roofs shall have a thickness of not less than 90 mm in cavity wall construction and 140 mm in single-leaf and collar-jointed wall construction and contain no openings wider than 2,5 m.

**4.2.2.6** The height of fill retained by foundation walls shall not exceed the values given in table 8.

**4.2.2.7** Foundation walls shall be of a thickness not less than the wall they support. The cores in hollow units and cavities in cavity walls shall be filled with grade 10 infill concrete.

### **4.2.3 Infill masonry panels in framed buildings**









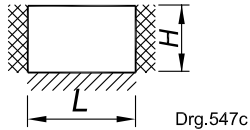
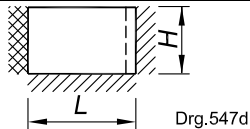
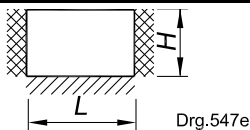
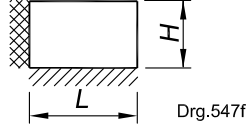
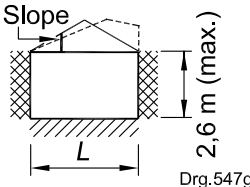
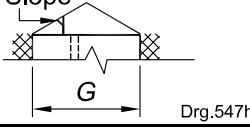

**4.2.3.1** Infill masonry wall panels in framed buildings of four storeys and less shall have dimensions not longer than those contained in table 3 or derived from figure 10 and tables 9 to 15, subject to the maximum lengths of openings and the minimum distances between the face of supports and openings and between successive openings being in accordance with figure 11 and table 7.

**4.2.3.2** Where collar joints in collar-jointed walls are not fully mortared, such walls shall, for the purposes of 4.2.3.1, be treated as cavity walls. Panels incorporating full height doors with fanlights shall be treated as panels supported on one side only and shall be sized in accordance with tables 14 and 15 (wall with openings).

**4.2.3.3** Vertical supports, which are provided by means of intersecting masonry walls, shall be in accordance with the requirements of 4.2.2.3.

**4.2.3.4** Infill masonry wall panels shall be connected to reinforced concrete columns in accordance with figures 12 to 15. All bed joint reinforcement shall be discontinuous across a tied joint.

**4.2.3.5** The joint between infill masonry wall panels and the underside of concrete beams or slab soffits shall be in accordance with figure 16.

Wall configuration	Table	Commentary									
 <p>External wall panel</p>	Table 1	<p>Applicable to panels that do not incorporate gable ends. Wall panel sizes are sensitive to panel openings.</p> <p>Two categories of opening are provided for:</p> <ol style="list-style-type: none"> <li>1) <math>\leq 15\%</math> wall area</li> <li>2) <math>&gt; 15\%</math> wall area</li> </ol>									
 <p>External wall panel</p>	Table 2	<p>Applicable to panels that do not incorporate gable ends. Wall panel sizes are sensitive to panel openings.</p> <p>Two categories of opening are provided for:</p> <ol style="list-style-type: none"> <li>1) <math>\leq 15\%</math> wall area</li> <li>2) <math>&gt; 15\%</math> wall area</li> </ol>									
 <p>Internal wall panel</p>	Table 3	Wall panel size is not governed by openings.									
 <p>Internal/external panel supported</p>	Table 4	Panels which incorporate full height doors are treated as walls supported on one side only with openings. Wall panel size is sensitive to openings (no size of opening is specified).									
 <p>2,6 m (max.)</p>	Table 5	<p>Applicable to panels that incorporate gable ends (or a portion thereof) which have a panel height that does not exceed 2,6 m.</p> <p>Wall panel size is sensitive to panel openings.</p> <p>Triangular portion of gable above eaves level shall be in accordance with table 6.</p> <p>Internal walls with gables (firewalls) shall be designed in accordance with table 1 (no openings).</p>									
 <p>G</p>	Table 6	The base width (G) shall be reduced by the length of any openings within the gable.									
<p><b>Key</b></p> <table style="width: 100%; border: none;"> <tr> <td style="width: 30%;"></td> <td style="width: 40%;">Horizontal support</td> <td style="width: 30%;"><math>L</math> = Length of panel</td> </tr> <tr> <td></td> <td>Vertical support (cross wall or return providing support)</td> <td><math>H</math> = Height of panel</td> </tr> <tr> <td></td> <td>Vertical support (tied butt control joint (see figure 7))</td> <td><math>G</math> = Base width of gable end</td> </tr> </table> <p>Drg.547i</p>				Horizontal support	$L$ = Length of panel		Vertical support (cross wall or return providing support)	$H$ = Height of panel		Vertical support (tied butt control joint (see figure 7))	$G$ = Base width of gable end
	Horizontal support	$L$ = Length of panel									
	Vertical support (cross wall or return providing support)	$H$ = Height of panel									
	Vertical support (tied butt control joint (see figure 7))	$G$ = Base width of gable end									

**Figure 4 — Table selection chart for the determination of wall panel sizes in single-storey and double-storey buildings**

**SANS 10400-K:2011**

Edition 3

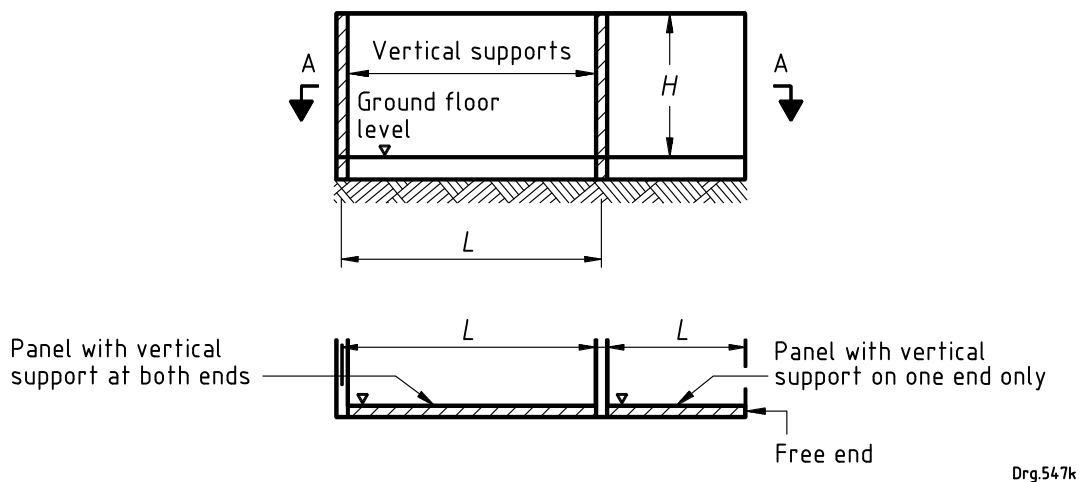

Drg.547k

**a) Panel proportions**

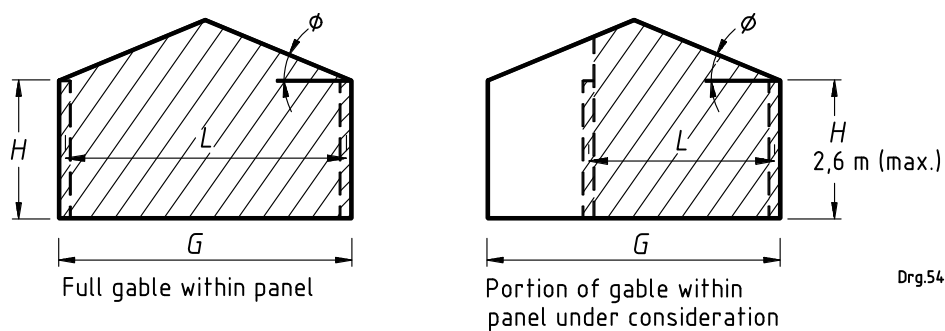

Drg.547l

**b) Gable end incorporating an isosceles triangle or portion thereof**

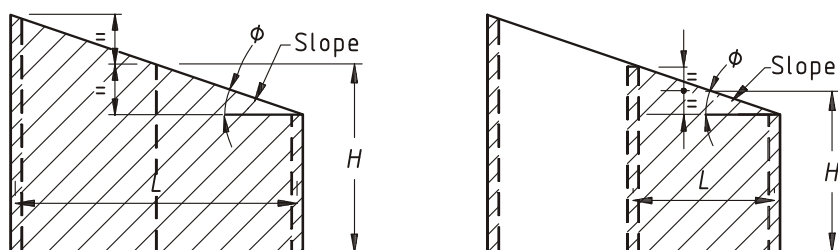

Drg.547m

**c) Monoslope gable end**

$H$  = height of panel  
 $L$  = horizontal distance between centres of vertical support  
 $G$  = base width of gable end

**Figure 5 — Wall panels in single-storey and double-storey buildings**

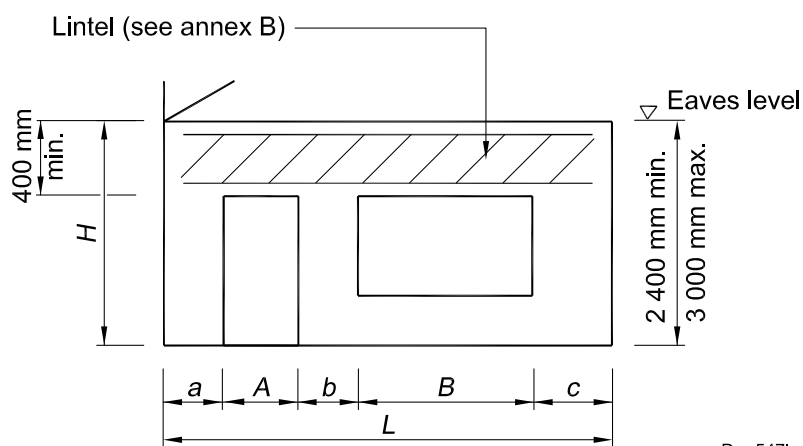

Drg.547j

**a) Wall with door and window openings**

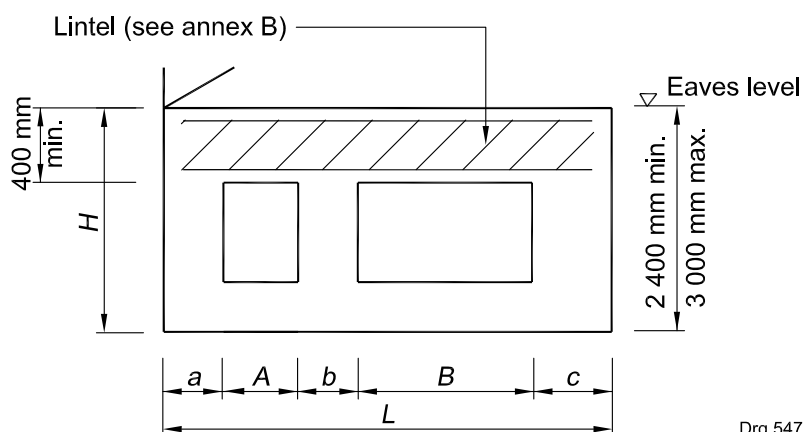

Drg.547ja

**b) Wall with window openings only**

**Single storey or upper storey with sheeted or tiled roof**

*a* and *c* not less than 150 mm (solid units) or 200 mm (hollow units)  
*b*, *A* and *B* in accordance with table 7

**Lower storey of double storey or single storey or upper storey with concrete roof**

*A* or *B* not greater than 2 500 mm

*a* not less than  $\frac{A}{x}$

*c* not less than  $\frac{B}{x}$

*b* not less than  $\frac{A + B}{x}$  or 300 mm (hollow unit filled with infill concrete)

or 300 mm (solid units)  
400 mm (hollow units)

where *x* = 6 for timber floor  
4 for concrete floor (span not greater than 4,5 m)  
3 for concrete floor (span not greater than 6,0 m)

**Figure 6 — Limitations on the size of openings in single-storey and double-storey buildings**

Table 1 – Maximum dimensions for external masonry wall panels supported on both sides

1	2	3	4	5	6	7	8	9	10	11	12	13	14
Nominal wall thickness mm	Wall type	Panel A No openings m				Panel B Openings ≤ 15 % wall area m				Panel C Openings > 15 % wall area m			
		L, max.	H	L	H, max.	L, max.	H	L	H, max.	L, max.	H	L	H, max.
<b>Solid units</b>													
90	Single-leaf	3,2	2,4	2,8	3,4	2,7	2,4	2,5	3,4	2,7	2,4	2,3	3,4
90-90	Cavity	5,5	2,7	5,5	3,9	5,5	2,7	5,0	3,9	5,5	2,4	4,5	3,9
110	Single-leaf	4,5	2,7	4,0	3,6	4,0	2,7	3,5	3,6	3,5	2,7	3,0	3,6
110-110	Cavity	7,0	3,3	6,0	4,4	7,0	2,4	5,5	4,4	6,5	2,4	5,0	4,4
140	Single-leaf	7,0	3,3	6,0	4,3	6,5	2,4	5,2	4,3	6,0	2,7	5,0	4,3
190	Collar-jointed	8,0	4,6	8,0	4,6	8,0	4,6	8,0	4,6	8,0	4,0	7,5	4,6
220	Collar-jointed	9,0	4,6	9,0	4,6	9,0	4,6	9,0	4,6	9,0	4,6	9,0	4,6
<b>Hollow units</b>													
90	Single-leaf	2,8	2,4	2,5	3,4	a	a	a	a	a	a	a	a
90-90	Cavity	5,0	2,7	4,5	3,9	4,5	2,4	4,0	3,9	4,0	2,7	3,5	3,9
110	Single-leaf	3,5	2,4	3,3	3,6	3,0	2,4	2,8	3,6	3,0	2,4	2,8	3,6
110-110	Cavity	6,0	2,4	5,0	4,2	5,0	2,4	4,2	4,2	4,5	2,7	4,2	4,2
140	Single-leaf	5,5	2,4	4,5	4,2	4,5	2,7	4,0	4,2	4,2	2,4	3,7	4,2
190	Single-leaf	7,5	2,7	6,0	4,4	6,5	2,4	5,0	4,6	6,0	2,7	4,8	4,4
<p>NOTE 1 Two alternative panel sizes (<math>L \times H</math>) are provided in respect of each panel type. Linear interpolation is permitted between these two sets of panel dimensions but not between wall types.</p> <p>NOTE 2 The values given in respect of solid units may be used for corresponding walls of hollow unit construction provided that the following reinforcement is provided:</p> <p>a) truss-type brickforce (see figure 1) that has main wires of not less than 3,55 mm diameter built into courses at vertical centres that do not exceed 400 mm; and</p> <p>b) either two 5,6 mm diameter rods in each leaf of walls in the bed joint immediately above window level, or a single Y8 bar in a bond block in 140 mm and 190 mm single-leaf walls at this same level;</p> <p>such reinforcements extending across the entire length of the panel and into the supports.</p> <p>NOTE 3 See figure 5 for definitions of <math>L</math> and <math>H</math>.</p>													
<p><sup>a</sup> Not permitted.</p>													

**Table 2 — Maximum dimensions for external masonry wall panels supported on both sides incorporating a tied control or articulation joint**

1	2	3	4	5	6	7	8	9	10	11	12	13	14
Nominal wall thickness mm	Wall type	Panel A No openings m				Panel B Openings ≤ 15 % wall area m				Panel C Openings > 15 % wall area m			
		L, max.	H	L	H, max.	L, max.	H	L	H, max.	L, max.	H	L	H, max.
<b>Solid units</b>													
90	Single-leaf	3,0	2,4	2,7	3,4	a	a	a	a	a	a	a	a
90-90	Cavity	5,5	2,7	5,0	3,9	5,0	2,7	4,5	3,9	4,5	2,7	4,0	3,9
110	Single-leaf	4,5	2,4	3,8	3,6	3,5	2,7	3,2	3,6	3,5	2,4	3,0	3,6
110-110	Cavity	7,0	3,0	5,5	4,4	6,5	2,4	5,0	4,4	6,0	2,4	4,5	4,4
140	Single-leaf	7,0	2,7	5,5	4,3	6,0	2,4	4,5	4,3	5,5	2,4	4,5	4,3
190	Collar-jointed	8,0	4,6	8,0	4,6	8,0	3,6	7,0	4,6	8,0	3,6	7,0	4,6
220	Collar-jointed	9,0	4,6	9,0	4,6	9,0	4,6	9,0	4,6	8,5	4,6	8,5	4,6
<b>Hollow units</b>													
90	Single-leaf	2,3	2,4	2,1	3,4	a	a	a	a	a	a	a	a
90-90	Cavity	5,0	2,4	4,5	3,9	4,0	2,7	3,5	3,9	4,0	2,7	3,5	3,9
110	Single-leaf	3,3	2,4	3,0	3,6	2,8	2,7	2,6	3,6	2,7	2,4	2,4	3,6
110-110	Cavity	5,5	2,4	4,5	4,2	4,5	2,4	4,0	4,2	4,3	2,4	3,7	4,2
140	Single-leaf	5,0	2,4	4,0	4,2	4,0	2,7	3,5	4,2	4,0	2,4	3,5	4,2
190	Single-leaf	7,0	2,7	6,0	4,4	6,0	2,4	4,5	4,4	5,5	2,4	4,5	4,4
<p>NOTE 1 Two alternative panel sizes (<math>L \times H</math>) are provided in respect of each panel type. Linear interpolation is permitted between these two sets of panel dimensions but not between wall panel types.</p> <p>NOTE 2 The values given in respect of solid units may be used for corresponding walls of hollow unit construction provided that the following reinforcement is provided:</p> <p>a) truss-type brickforce (see figure 1) that has main wires of not less than 3,55 mm diameter built into courses at vertical centres that do not exceed 400 mm; and</p> <p>b) two 5,6 mm diameter rods in each leaf of walls in the bed joint immediately above the window level, or a single Y8 bar in a bond block in 140 mm and 190 mm single-leaf walls at this same level;</p> <p>such reinforcement extending across the entire length of the panel and into the supports.</p> <p>NOTE 3 See figure 5 for definitions of <math>L</math> and <math>H</math>.</p> <p>NOTE 4 See figure 7 for the location and details of the tied control joint.</p>													
<p><sup>a</sup> Not permitted.</p>													

**SANS 10400-K:2011**  
Edition 3

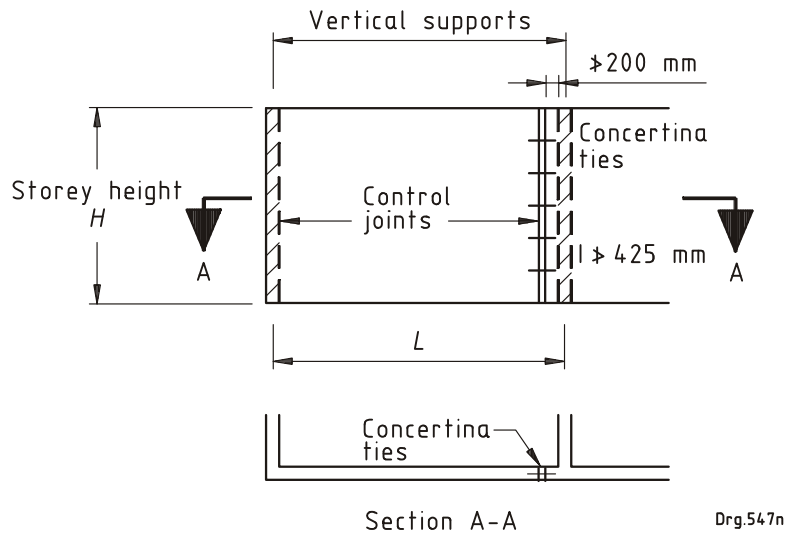

Concertina ties shall be placed in bed joints at centres that do not exceed 425 mm.

Dowels shall be placed in hollow unit bond beams instead of concertina ties (see figure 7(e)).

**a) Location of concertina ties**

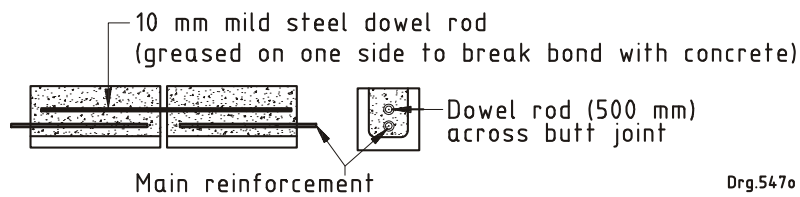

**b) Section through hollow unit bond beam at tied control joint**

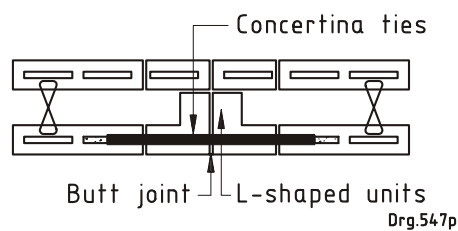

**c) Cavity wall detail at joint**

**Figure 7 — Tied butt control joint details (lateral stability)**



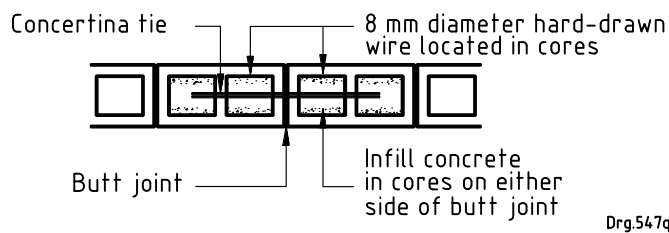

**d) Hollow single-leaf wall detail at joint**

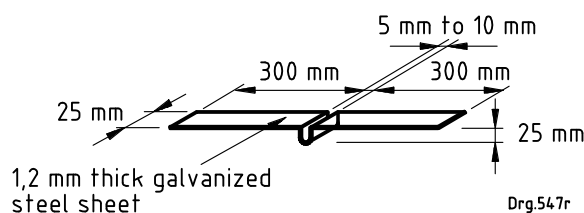

**e) Concertina tie detail**

**Figure 7 — Tied butt control joint details (lateral stability) (concluded)**

**Table 3 — Maximum dimensions for internal masonry wall panels supported on both sides with or without openings**

1	2	3	4
Nominal wall thickness mm	Wall type	Internal wall panel with or without openings m	
		<i>L</i>	<i>H</i>
<b>Solid unit</b>			
90	Single-leaf	4,5	3,4
90-90	Cavity	6,0	3,9
110	Single-leaf	5,5	3,6
110-110	Cavity	7,0	4,4
140	Single-leaf	7,0	4,3
190	Collar-jointed	8,5	4,6
220	Collar-jointed	9,0	4,6
<b>Hollow unit</b>			
90	Single-leaf	4,5	3,4
90-90	Cavity	5,5	3,9
110	Single-leaf	6,0	3,6
110-110	Cavity	7,0	4,4
140	Single-leaf	8,0	4,6
190	Single-leaf	8,5	4,6

NOTE 1 Internal panel lengths for gables (firewalls) that have slopes within the range presented, may be based on the maximum length given in respect of a wall without openings in accordance with column 3 (panel A) of table 1.

NOTE 2 See figure 5 for definitions of *L* and *H*.

**SANS 10400-K:2011**

Edition 3

**Table 4 — Maximum dimensions for internal and external masonry wall panels supported on one vertical side only**

1	2	3	4	5	6	7	8
Nominal wall thickness  mm	Wall type	Internal wall panel with or without openings		External wall panels			
		m		Without openings		With openings	
		<i>L</i>	<i>H</i>	<i>L</i>	<i>H</i>	<i>L</i>	<i>H</i>
<b>Solid unit</b>							
90	Single-leaf	1,4	3,4	1,4	3,4	1,2	3,0
90-90	Cavity	2,1	3,9	2,1	3,9	1,8	3,6
110	Single-leaf	2,0	3,6	2,0	3,6	1,6	3,6
110-110	Cavity	2,6	4,4	2,6	4,4	2,1	3,6
140	Single-leaf	2,5	4,3	2,5	4,3	2,0	3,6
190	Collar-jointed	3,4	4,6	3,4	4,6	2,7	3,6
220	Collar-jointed	4,0	4,6	4,0	4,6	3,1	3,6
<b>Hollow unit</b>							
90	Single-leaf	1,4	3,4	1,4	3,4	1,2	3,0
90-90	Cavity	2,1	3,9	2,1	3,9	1,8	3,6
110	Single-leaf	2,0	3,6	2,0	3,6	1,8	3,3
110-110	Cavity	2,6	4,4	2,6	4,4	2,0	3,3
140	Single-leaf	2,5	4,3	2,5	3,6	1,8	3,0
190	Single-leaf	3,4	4,6	3,4	3,6	2,4	3,3
NOTE 1 Where collar joints in collar-jointed walls are not fully mortared, such walls are structurally equivalent to cavity walls.							
NOTE 2 See figure 5 for definitions of <i>L</i> and <i>H</i> .							

**Table 5 — Maximum length (*L*) of external masonry wall panel not exceeding 2,6 m in height supporting a free-standing (isosceles) gable triangle or portion thereof**

1	2	3	4	5	6	7	8	9	10	11	12
Nominal wall thickness mm	Wall type	Without opening m					With opening m				
		Slope									
		≤ 11°	15°	17°	22°	26°	≤ 11°	15°	17°	22°	26°
<b>Solid units</b>											
90	Single-leaf	2,8	2,7	2,6	2,6	2,6	2,4	2,4	2,4	2,4	2,4
90-90	Cavity	5,5	5,5	5,5	5,0	5,0	4,5	4,5	4,0	4,0	4,0
110	Single-leaf	4,5	4,5	4,5	4,0	4,0	4,0	4,0	3,5	3,5	3,5
110-110	Cavity	7,0	7,0	6,5	6,0	6,0	6,0	5,5	5,5	5,0	5,0
140	Single-leaf	6,5	6,0	5,5	5,5	5,5	5,0	5,0	4,5	4,5	4,5
190	Collar-jointed	8,0	8,0	8,0	8,0	8,0	8,0	7,5	7,5	7,0	6,5
220	Collar-jointed	8,0	8,0	8,0	8,0	8,0	8,0	8,0	8,0	8,0	8,0
<b>Hollow units</b>											
90	Single-leaf	2,5	2,5	2,5	2,5	2,5	2,1	2,1	2,1	2,0	2,0
90-90	Cavity	4,5	4,5	4,0	4,0	4,0	3,5	3,5	3,5	3,5	3,5
110	Single-leaf	3,5	3,5	3,3	3,3	3,0	3,0	3,0	2,8	2,7	2,7
110-110	Cavity	5,5	5,5	5,0	5,0	5,0	4,5	4,5	4,0	4,0	4,0
140	Single-leaf	4,5	4,5	4,5	4,0	4,0	4,0	3,5	3,5	3,3	3,3
190	Single-leaf	6,0	5,5	5,5	5,0	5,0	5,0	5,0	5,0	4,5	4,5
<p>NOTE 1 The values given in respect of solid units may be used for corresponding walls of hollow unit construction provided that the following reinforcement is provided:</p> <p>a) truss-type brickforce (see figure 1) that has main wires of not less than 3,55 mm diameter at vertical centres that do not exceed 400 mm; and</p> <p>b) two 5,6 mm diameter rods in each leaf of walls in the bed joint immediately above the window level, or a single Y8 bar in a bond block in 140 mm and 190 mm single-leaf walls at this level;</p> <p>such reinforcement extending across the entire length of the panel and into the supports.</p> <p>NOTE 2 See figure 5 for the definition of <i>L</i>.</p>											

**SANS 10400-K:2011**

Edition 3

**Table 6 — Maximum base width (G) of external triangular masonry gable ends**

1	2	3	4	5	6	7
Nominal wall thickness mm	Wall type	Maximum base width (G) m				
		Slope				
		≤ 11°	15°	17°	22°	26°
<b>Solid units</b>						
90	Single-leaf	6,0	6,0	6,0	5,0	4,5
90-90	Cavity	8,0	8,0	8,0	7,5	6,5
110	Single-leaf	6,0	6,0	6,0	5,0	5,5
110-110	Cavity	8,0	8,0	8,0	8,0	7,5
140	Single-leaf	8,0	8,0	8,0	8,0	7,0
190	Collar-jointed	8,0	8,0	8,0	8,0	8,0
220	Collar-jointed	8,0	8,0	8,0	8,0	8,0
<b>Hollow units</b>						
90	Single-leaf	6,0	6,0	6,0	5,0	4,0
90-90	Cavity	8,0	8,0	8,0	7,0	5,5
110	Single-leaf	6,0	6,0	6,0	5,0	4,5
110-110	Cavity	8,0	8,0	8,0	8,0	6,5
140	Single-leaf	8,0	8,0	8,0	7,0	6,0
190	Single-leaf	8,0	8,0	8,0	8,0	7,5
NOTE 1 Where openings are provided within the gable, reduce the permissible value of G by the width of such openings.						
NOTE 2 The maximum base width of internal gables (firewalls), for the range of slopes presented, may be taken as that given in respect of a slope of 11°.						
NOTE 3 See figure 5 for the definition of G.						

**SANS 10400-K:2011**

Edition 3

**Table 7 — Critical dimensions of openings and edge distances in respect of single-storey/upper-storey external masonry wall panels supporting sheeted or tiled roofs**

1	2	3	4	5
Nominal wall thickness	Wall type	Minimum length of dimension <i>b</i>	Maximum length of dimension <i>A</i> or <i>B</i>	Maximum length of sum of dimensions <i>A</i> or <i>B</i>
mm		mm	m	m
<b>Solid units</b>				
90	Single-leaf	600	2,0	2,0
90-90	Cavity	300	3,0	3,5
110	Single-leaf	500	2,5	3,0
110-110	Cavity	300	3,0	4,0
140	Single-leaf	300	3,0	4,0
190	Collar-jointed	300	3,5	4,5
220	Collar-jointed	300	3,5	5,5
<b>Hollow units</b>				
90	Single-leaf	600	2,0	2,0
90-90	Cavity	600	2,5	2,5
110	Single-leaf	400	2,5	3,5
110-110	Cavity	400	3,0	4,0
140	Single-leaf	400	3,0	4,0
190	Single-leaf	400	3,5	4,5
NOTE See figure 6 for definitions of dimensions <i>A</i> , <i>b</i> and <i>B</i> .				

**SANS 10400-K:2011**

Edition 3

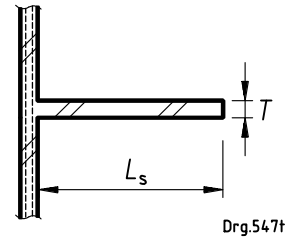
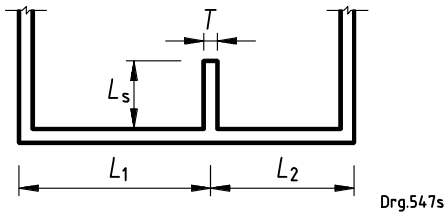

$$L_s = \text{greater of } \frac{L_1 + L_2}{2x} \text{ and } 500 \text{ mm}$$

$$L_s = \text{greater of } H/8 \text{ and } L/10$$

where

$$x = 2,5 \text{ for } T \leq 110 \text{ mm}$$

$$x = 3,0 \text{ for } T \geq 140 \text{ mm}$$

**b) Plan — Internal wall panels**

**a) Plan — External wall panels**

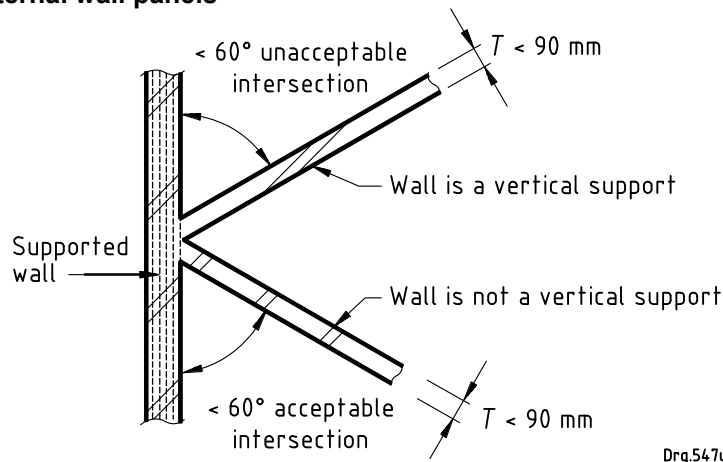

**Plan**

Drg.547u

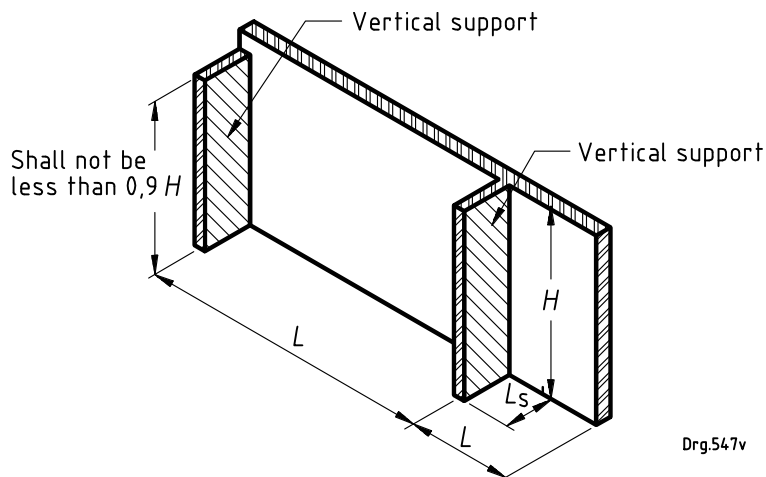

Drg.547v

**c) Vertical supports**

NOTE See figure 5 for the definitions of *L* and *H*.

**Figure 8 — Lateral support provided by intersecting walls**

**Table 8 — Maximum height of masonry foundation walls where fill is retained behind the wall**

1	2	3
Nominal wall thickness mm	Wall type	Maximum difference in ground levels, $h$ (see figure 9) mm
90 and 110	Single-leaf	200
140	Single-leaf	400
190	Single-leaf/collar-jointed	600
220	Collar-jointed	700
90-90	Cavity	700
110-110	Cavity	1 000
290	Collar-jointed	1 000
330	Collar-jointed	1 200

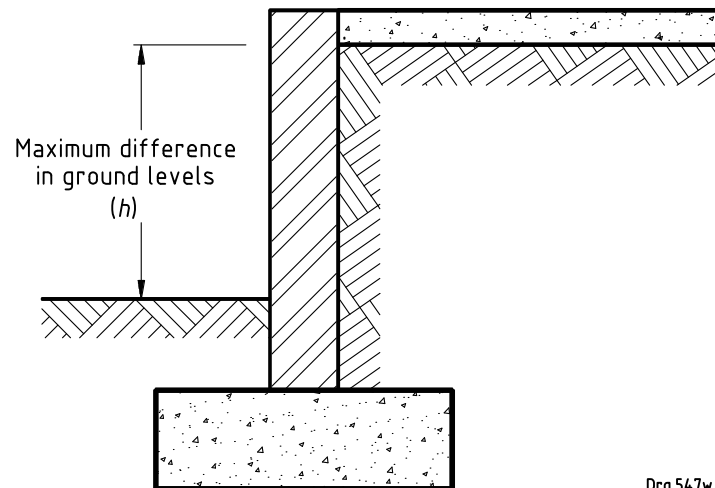











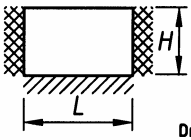
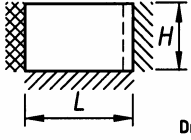
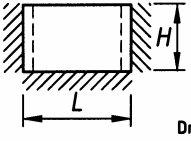
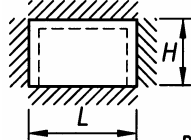
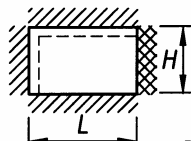
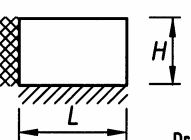
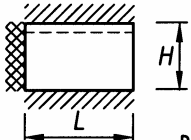





Drg.547w

**Figure 9 — Foundation walls**

Table 9 — External infill panel in framed buildings supported on both sides

1	2	3	4	5	6	7	8	9	10	11	12	13	14
Nominal wall thickness mm	Wall type	Panel A No openings m				Panel B Openings ≤ 15 % wall area m				Panel C Openings > 15 % wall area m			
		L, max.	H	L	H, max.	L, max.	H	L	H, max.	L, max.	H	L	H, max.
<b>Solid units</b>													
90-90	Cavity	5,5	2,7	5,0	3,3	4,7	2,4	4,2	3,3	4,5	2,4	4,2	3,3
110-110	Cavity	7,0	2,7	6,5	3,3	6,0	2,4	5,5	3,3	5,7	2,4	5,2	3,3
140	Single-leaf	7,0	2,4	6,0	3,3	6,0	2,4	5,2	3,3	5,5	2,4	5,0	3,3
190	Collar-jointed	8,0	3,3	8,0	3,3	8,0	3,3	8,0	3,3	8,0	3,3	8,0	3,3
220	Collar-jointed	9,0	3,3	9,0	3,3	9,0	3,3	9,0	3,3	9,0	3,3	9,0	3,3
<b>Hollow units</b>													
90-90	Cavity	4,5	2,4	4,0	3,3	3,8	2,4	3,5	3,3	3,5	2,4	3,3	3,3
110-110	Cavity	6,0	2,4	5,2	2,4	4,9	2,4	4,4	3,3	4,6	2,4	4,3	3,3
140	Single-leaf	4,7	2,4	4,3	3,3	4,0	2,4	3,7	3,3	3,8	2,4	3,6	3,3
190	Single-leaf	7,0	2,4	6,0	3,3	5,6	2,4	5,0	3,3	5,4	2,4	4,9	3,3
<p>NOTE 1 Two alternative panel sizes (<math>L \times H</math>) are provided in respect of each panel type. Linear interpolation is permitted between these two sets of panel dimensions but not between wall types.</p> <p>NOTE 2 The values given in respect of solid units may be used for corresponding walls of hollow unit construction provided that the following reinforcement is provided:</p> <p>a) truss-type brickforce (see figure 1) that has main wires of not less than 3,55 mm diameter built into courses at vertical centres that do not exceed 400 mm; and</p> <p>b) two 5,6 mm diameter rods in each leaf of walls in the bed joint immediately above window level, or a single Y8 bar in a bond block in 140 mm and 190 mm single-leaf walls at this same level;</p> <p>such reinforcements extending across the entire length of the panel and into the supports.</p> <p>NOTE 3 See figure 11 for definitions of <math>L</math> and <math>H</math>.</p>													



External wall configuration	Table	Joints to frame members (see figures 12 to 15)																				
 <p>Drg.547c</p>	Table 9	Top type IV or free edge LHS type I RHS type I																				
 <p>Drg.547y</p>	Table 10	Top type IV or free edge LHS type I RHS type II																				
 <p>Drg.547z</p>	Table 11	Top type IV or free edge LHS type II RHS type II																				
 <p>Drg.548</p>	Table 12	Top type III LHS type II RHS type II																				
 <p>Drg.548a</p>	Table 13	Top type III LHS type II RHS type I																				
 <p>Drg.548b</p>	Table 14	Top type IV or free edge LHS type I																				
 <p>Drg.548c</p>	Table 15	Top type III LHS type I																				
<p><b>Key</b></p> <table style="width: 100%; border: none;"> <tr> <td style="width: 30px;"></td> <td>Free edge or type IV movement joint</td> <td style="width: 300px;"></td> <td>LHS = left-hand side</td> </tr> <tr> <td></td> <td>Horizontal support at base of wall</td> <td></td> <td>RHS = right-hand side</td> </tr> <tr> <td></td> <td>Type III movement joint at the top of the wall</td> <td></td> <td></td> </tr> <tr> <td></td> <td>Vertical support (without movement joint or with type I movement joint)</td> <td></td> <td></td> </tr> <tr> <td></td> <td>Vertical support with type II movement joint</td> <td></td> <td></td> </tr> </table> <p>Drg.548d</p>				Free edge or type IV movement joint		LHS = left-hand side		Horizontal support at base of wall		RHS = right-hand side		Type III movement joint at the top of the wall				Vertical support (without movement joint or with type I movement joint)				Vertical support with type II movement joint		
	Free edge or type IV movement joint		LHS = left-hand side																			
	Horizontal support at base of wall		RHS = right-hand side																			
	Type III movement joint at the top of the wall																					
	Vertical support (without movement joint or with type I movement joint)																					
	Vertical support with type II movement joint																					

**Figure 10 — Table selection chart for the determination of wall panel sizes in framed buildings**

**SANS 10400-K:2011**  
Edition 3

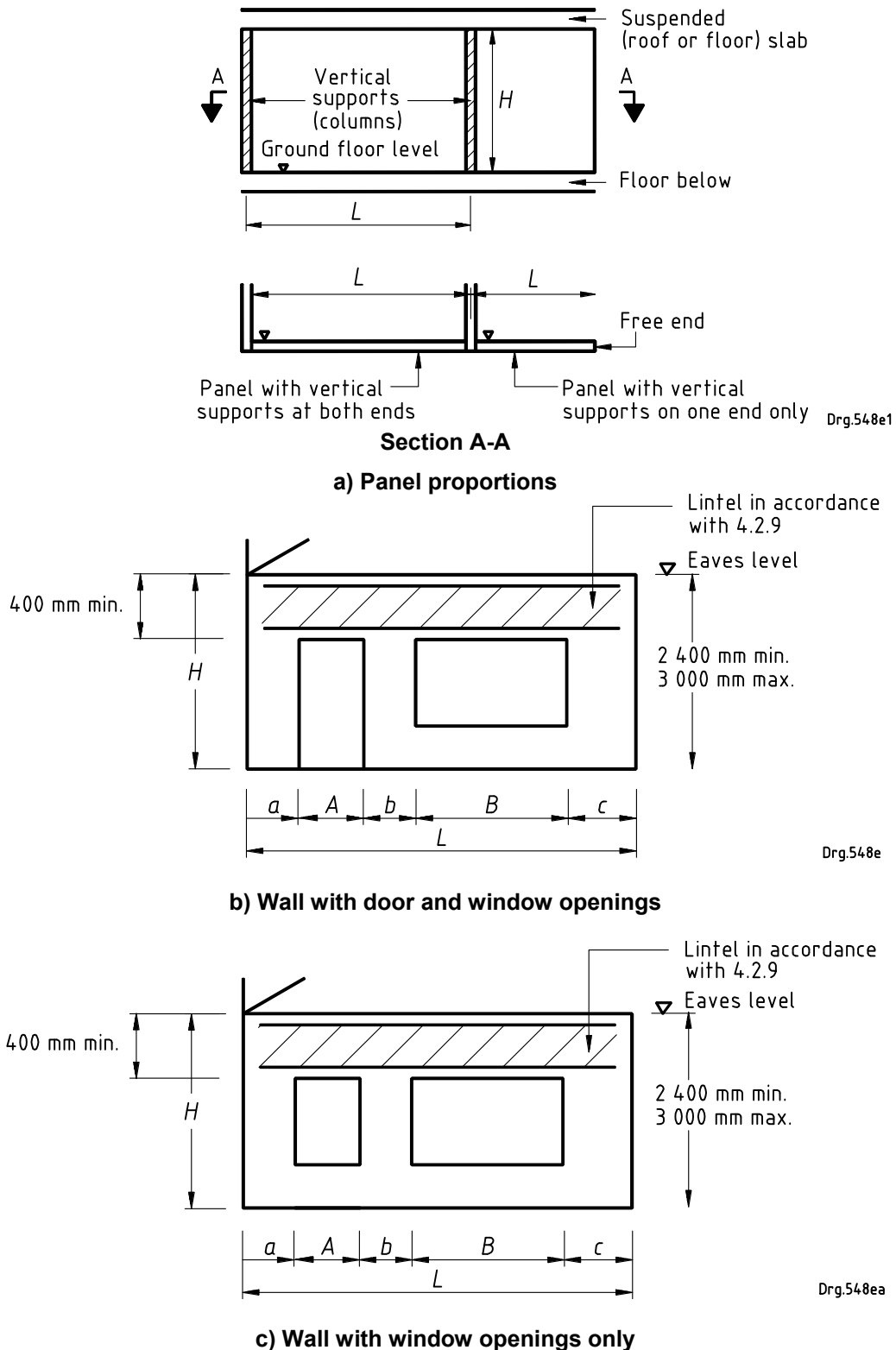

$a$  and  $c$  shall not be less than 150 mm (solid units) or 200 mm (hollow units).  
 $b$ ,  $A$  and  $B$  shall be in accordance with table 7.

$H$  = panel height  
 $L$  = horizontal distance between centres of vertical support

**Figure 11 — Wall panels in framed buildings — Definition sketches**

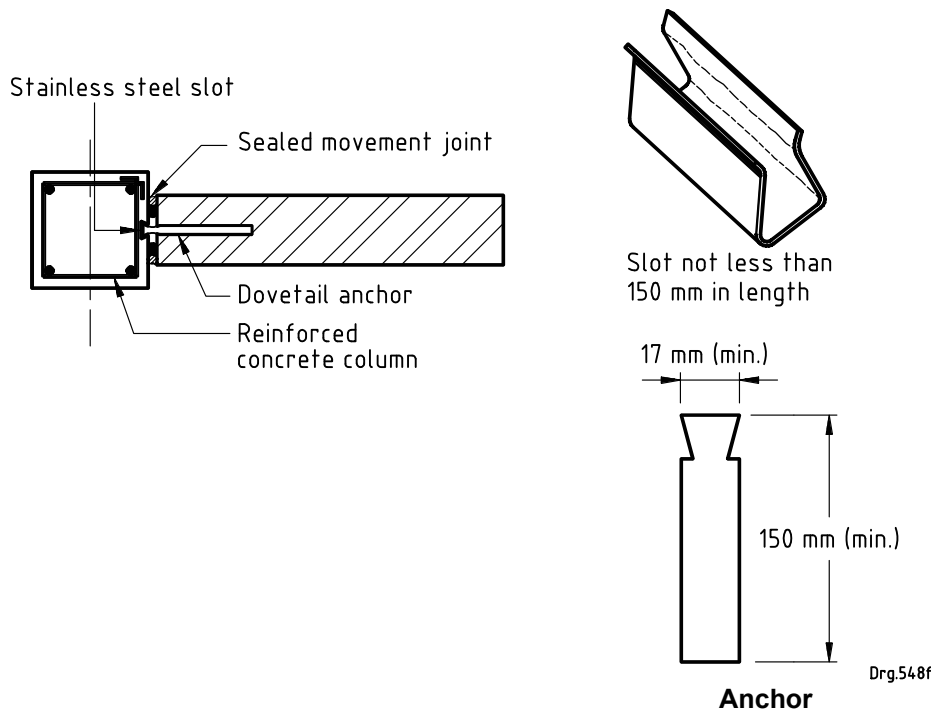
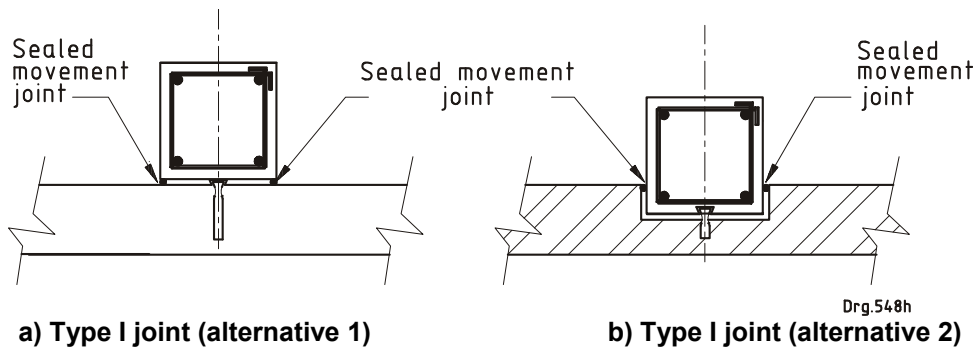

c) Type II joint (alternative 1)

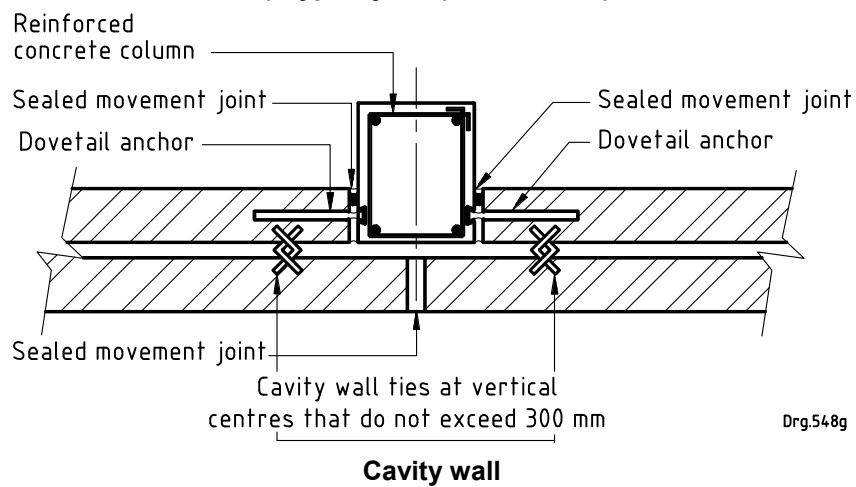

d) Type II joint (alternative 2)

Figure 12 — Movements joints between masonry walling and concrete columns using dovetail slot anchors (type I and type II joints)

**SANS 10400-K:2011**  
Edition 3

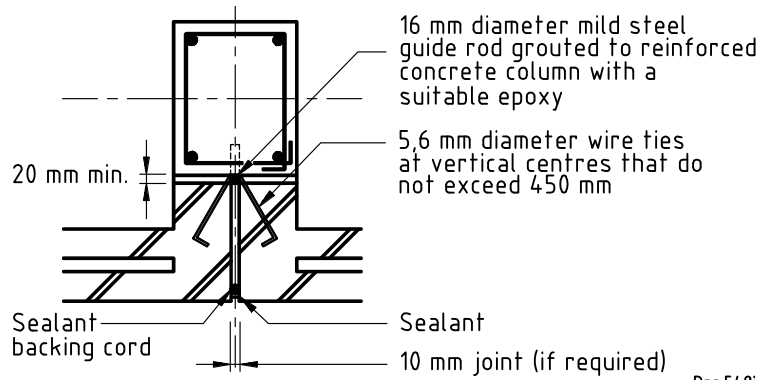

**a) Movement joint in cavity walls**

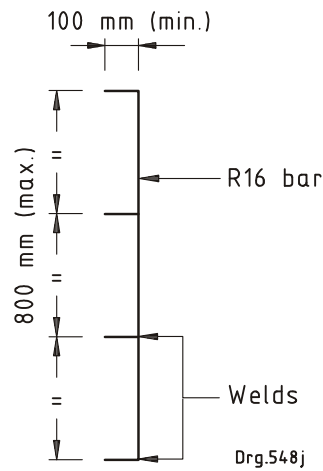

**Guide rod detail**

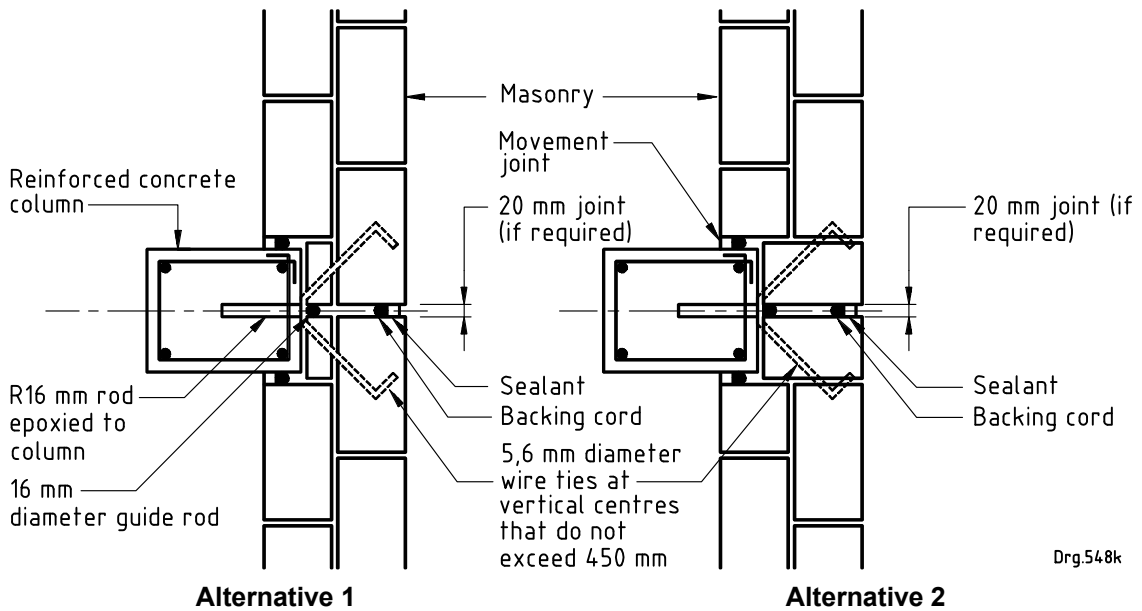

**b) Movement joint in collar-jointed wall**

**Figure 13 — Movement joints between masonry walling and concrete columns using sliding anchors (type II joints)**

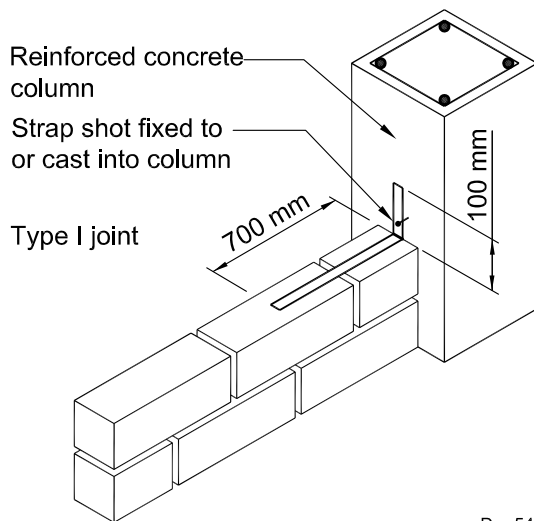

Drg.548l

**a) Isometric view of fixing to column (type I joint)**

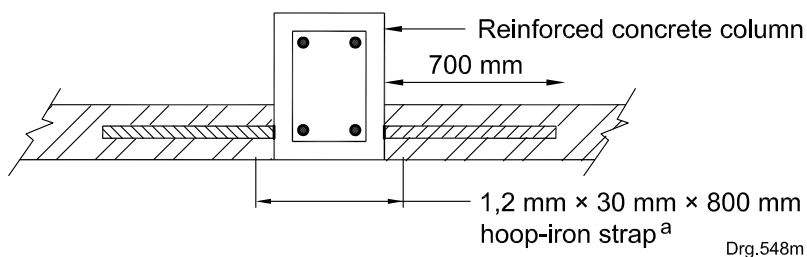

**b) Fixing detail for single-leaf and collar-jointed walls (type I joint)**

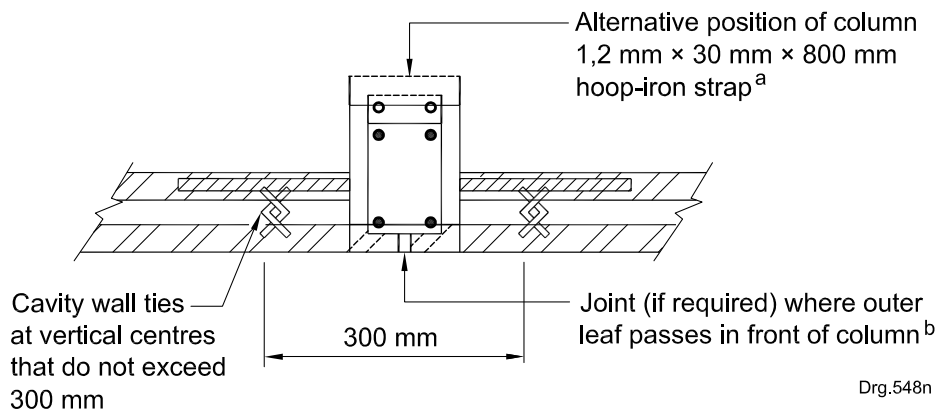

**c) Fixing detail for cavity walls (type I or type II joint)**

The drive pin shall be located as close to the bend in the strap as is practicable.

Cores in hollow units shall be filled with infill concrete.

<sup>a</sup> The first 100 mm in hoop-iron straps shall be either fixed to concrete by means of a 3,0 mm diameter (min.) drive pin or cast into concrete at vertical centres that do not exceed 450 mm.

<sup>b</sup> The joint is a type I joint where no joint is provided in front of the column. The joint is a type II joint where a joint is provided in front of the column.

**Figure 14 — Fixing of masonry walling to concrete columns (type I and type II joints)**

**SANS 10400-K:2011**

Edition 3

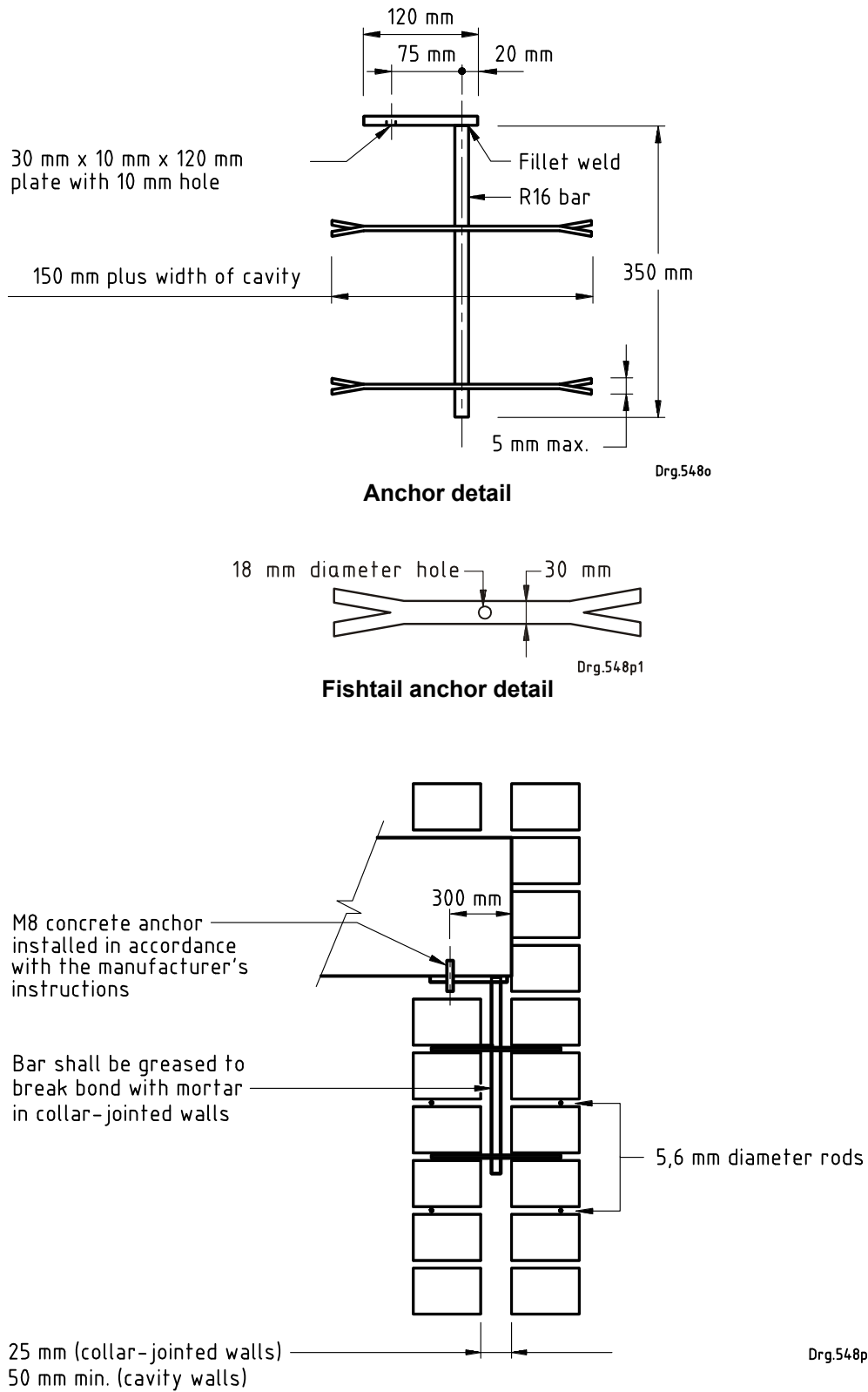

**Figure 15 — Details for fixing masonry walls to slab soffits (solid units) (type III joint)**

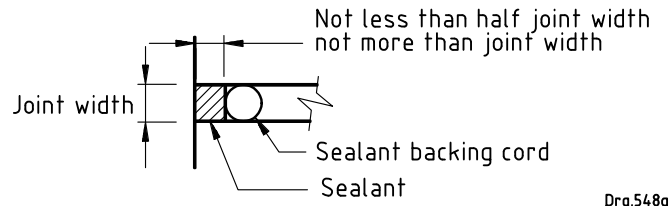

**Sealant detail**

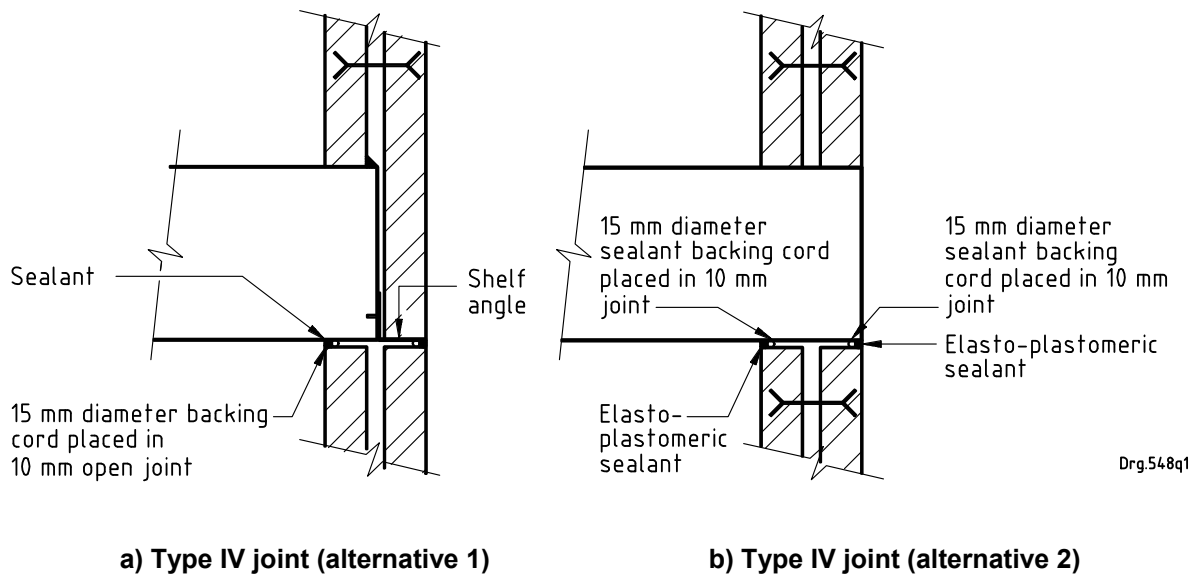

**Figure 16 — Horizontal joints at tops of masonry infill panels (type IV joint)**

**Table 10 — External infill panel in framed buildings supported on both sides incorporating a movement joint on one side**

1	2	3	4	5	6	7	8	9	10	11	12	13	14
Nominal wall thickness mm	Wall type	Panel A No openings m				Panel B Openings ≤ 15 % wall area m				Panel C Openings > 15 % wall area m			
		L, max.	H	L	H, max.	L, max.	H	L	H, max.	L, max.	H	L	H, max.
<b>Solid units</b>													
90-90	Cavity	5,0	2,4	4,2	3,3	3,8	2,4	3,5	3,3	3,7	2,4	3,2	3,3
110-110	Cavity	6,5	2,4	5,5	3,3	5,0	2,4	4,2	3,3	4,7	2,4	4,1	3,3
140	Single-leaf	6,0	2,4	5,3	3,3	4,7	2,4	4,2	3,3	4,5	2,4	4,0	3,3
190	Collar-jointed	8,0	3,3	8,0	3,3	8,0	2,4	6,7	3,3	6,5	2,4	6,2	3,3
220	Collar-jointed	9,0	3,3	9,0	3,3	9,0	3,0	8,5	3,3	9,0	2,4	8,0	3,3
<b>Hollow units</b>													
90-90	Cavity	3,8	2,4	3,3	3,3	3,0	2,4	2,7	3,3	2,8	2,4	2,6	3,3
110-110	Cavity	5,1	2,4	4,5	3,3	4,0	2,4	3,6	3,3	3,7	2,4	3,3	3,3
140	Single-leaf	4,1	2,4	3,7	3,3	3,3	2,4	3,0	3,3	3,0	2,4	2,8	3,3
190	Single-leaf	5,8	2,4	5,1	3,3	4,5	2,4	4,1	3,3	4,3	2,4	3,8	3,3
<p>NOTE 1 Two alternative panel sizes (<math>L \times H</math>) are provided in respect of each panel type. Linear interpolation is permitted between these two sets of panel dimensions but not between wall types.</p> <p>NOTE 2 The values given in respect of solid units may be used for corresponding walls of hollow unit construction provided that the following reinforcement is provided:</p> <p>a) truss-type brickforce (see figure 1) that has main wires of not less than 3,55 mm diameter built into courses at vertical centres that do not exceed 400 mm; and</p> <p>b) either two 5,6 mm diameter rods in each leaf of walls in the bed joint immediately above window level, or a single Y8 bar in a bond block in 140 mm and 190 mm single-leaf walls at this same level;</p> <p>such reinforcements extending across the entire length of the panel and into the supports.</p> <p>NOTE 3 See figure 11 for definitions of <math>L</math> and <math>H</math>.</p>													



**Table 11 — External infill panel in framed buildings supported on both sides incorporating movement joints on both sides**

1	2	3	4	5	6	7	8	9	10	11	12	13	14
Nominal wall thickness mm	Wall type	Panel A No openings m				Panel B Openings ≤ 15 % wall area m				Panel C Openings > 15 % wall area m			
		L, max.	H	L	H, max.	L, max.	H	L	H, max.	L, max.	H	L	H, max.
<b>Solid units</b>													
90-90	Cavity	4,0	2,4	3,5	3,3	3,0	2,4	2,7	3,3	2,7	2,4	2,4	3,3
110-110	Cavity	5,3	2,4	5,0	3,3	3,8	2,4	3,3	3,3	3,3	2,4	3,0	3,3
140	Single-leaf	5,0	2,4	4,2	3,3	3,6	2,4	3,3	3,3	3,3	2,4	2,9	3,3
190	Collar-jointed	8,0	2,7	7,0	3,3	6,0	2,4	5,0	3,3	5,2	2,4	4,5	3,3
220	Collar-jointed	9,0	3,3	9,0	3,3	8,0	2,4	6,5	3,3	7,0	2,4	5,5	3,3
<b>Hollow units</b>													
90-90	Cavity	3,1	2,4	2,8	3,3	2,3	2,4	2,1	3,3	a	a	a	a
110-110	Cavity	4,3	2,4	3,7	3,3	3,0	2,4	2,7	3,3	2,8	2,4	2,5	3,3
140	Single-leaf	3,4	2,4	3,3	3,3	2,5	2,4	2,3	3,3	2,3	2,4	2,1	3,3
190	Single-leaf	5,0	2,4	4,3	3,3	3,8	2,4	3,3	3,3	3,3	2,4	2,8	3,3
<p>NOTE 1 Two alternative panel sizes (<math>L \times H</math>) are provided in respect of each panel type. Linear interpolation is permitted between these two sets of panel dimensions but not between wall types.</p> <p>NOTE 2 The values given in respect of solid units may be used for corresponding walls of hollow unit construction provided that the following reinforcement is provided:</p> <p>a) truss-type brickforce (see figure 1) that has main wires of not less than 3,55 mm diameter built into courses at vertical centres that do not exceed 400 mm; and</p> <p>b) either two 5,6 mm diameter rods in each leaf of walls in the bed joint immediately above window level, or a single Y8 bar in a bond block in 140 mm and 190 mm single-leaf walls at this same level;</p> <p>such reinforcements extending across the entire length of the panel and into the supports.</p> <p>NOTE 3 See figure 11 for definitions of <math>L</math> and <math>H</math>.</p>													
<p><sup>a</sup> Not permitted.</p>													

**Table 12 — External infill panel in framed buildings supported on both sides and top by means of movement joints**

1	2	3	4	5	6	7	8	9	10	11	12	13	14
Nominal wall thickness  mm	Wall type	Panel A No openings m				Panel B Openings ≤ 15 % wall area m				Panel C Openings > 15 % wall area m			
		L, max.	H	L	H, max.	L, max.	H	L	H, max.	L, max.	H	L	H, max.
<b>Solid units</b>													
90-90	Cavity	5,5	2,7	4,5	3,3	4,0	2,4	3,0	3,3	3,5	2,4	2,8	3,3
110-110	Cavity	7,0	3,3	7,0	3,3	7,0	2,4	4,5	3,3	6,0	2,4	4,0	3,3
190	Collar-jointed	8,0	3,3	8,0	3,3	8,0	3,3	8,0	3,3	8,0	3,0	7,5	3,3
220	Collar-jointed	9,0	3,3	9,0	3,3	9,0	3,3	9,0	3,3	9,0	3,3	9,0	3,3
<b>Hollow units</b>													
90-90	Cavity	4,5	2,4	3,3	3,3	3,0	2,4	2,5	3,3	2,7	2,4	2,2	3,3
110-110	Cavity	6,0	2,7	4,8	3,3	4,5	2,4	3,3	3,3	4,0	2,4	2,9	3,3
<p>NOTE 1 Two alternative panel sizes (<math>L \times H</math>) are provided in respect of each panel type. Linear interpolation is permitted between these two sets of panel dimensions but not between wall types.</p> <p>NOTE 2 The values given in respect of solid units may be used for corresponding walls of hollow unit construction provided that the following reinforcement is provided:</p> <p>a) truss-type brickforce (see figure 1) that has main wires of not less than 3,55 mm diameter built into courses at vertical centres that do not exceed 400 mm; and</p> <p>b) either two 5,6 mm diameter rods in each leaf of walls in the bed joint immediately above window level, or a single Y8 bar in a bond block in 140 mm and 190 mm single-leaf walls at this same level;</p> <p>such reinforcements extending across the entire length of the panel and into the supports.</p> <p>NOTE 3 See figure 11 for definitions of <math>L</math> and <math>H</math>.</p>													

**Table 13 — External infill panel in framed buildings supported on both sides and on top incorporating a movement joint on one side and at the top**

1	2	3	4	5	6	7	8	9	10	11	12	13	14
Nominal wall thickness mm	Wall type	Panel A No openings m				Panel B Openings ≤ 15 % wall area m				Panel C Openings > 15 % wall area m			
		L, max.	H	L	H, max.	L, max.	H	L	H, max.	L, max.	H	L	H, max.
<b>Solid units</b>													
90-90	Cavity	6,0	2,4	5,5	3,3	5,5	2,4	4,2	3,3	5,0	2,4	3,8	3,3
110-110	Cavity	7,0	3,3	7,0	3,3	7,0	2,7	6,0	3,3	7,0	2,4	5,5	3,3
190	Collar-jointed	8,0	3,3	8,0	3,3	8,0	3,3	8,0	3,3	8,0	3,3	8,0	3,3
220	Collar-jointed	9,0	3,3	9,0	3,3	9,0	3,3	9,0	3,3	9,0	3,3	9,0	3,3
<b>Hollow units</b>													
90-90	Cavity	5,5	2,4	4,0	3,3	4,0	2,4	3,2	3,3	3,5	2,4	3,0	3,3
110-110	Cavity	7,0	2,4	5,5	3,3	6,0	2,4	4,3	3,3	5,0	2,4	4,0	3,3
<p>NOTE 1 Two alternative panel sizes (<math>L \times H</math>) are provided in respect of each panel type. Linear interpolation is permitted between these two sets of panel dimensions but not between wall types.</p> <p>NOTE 2 The values given in respect of solid units may be used for corresponding walls of hollow unit construction provided that the following reinforcement is provided:</p> <p>a) truss-type brickforce (see figure 1) that has main wires of not less than 3,55 mm diameter built into courses at vertical centres that do not exceed 400 mm; and</p> <p>b) either two 5,6 mm diameter rods in each leaf of walls in the bed joint immediately above window level, or a single Y8 bar in a bond block in 140 mm and 190 mm single-leaf walls at this same level;</p> <p>such reinforcements extending across the entire length of the panel and into the supports.</p> <p>NOTE 3 See figure 11 for definitions of <math>L</math> and <math>H</math>.</p>													

**SANS 10400-K:2011**

Edition 3

**Table 14 — Maximum dimensions for internal and external infill panels in framed buildings  
(panels supported on one vertical side only)**

1	2	3	4	5	6	7	8
Nominal wall thickness  mm	Wall type	Internal wall panel with or without openings  m		External wall panel m			
				Without openings		With openings	
		<i>L</i>	<i>H</i>	<i>L</i>	<i>H</i>	<i>L</i>	<i>H</i>
<b>Solid units</b>							
90	Single-leaf	1,4	3,3	1,4	3,3	1,2	3,0
90-90	Cavity	2,1	3,3	2,1	3,3	1,8	3,3
110	Single-leaf	2,0	3,3	2,0	3,3	1,6	3,3
110-110	Cavity	2,6	3,3	2,6	3,3	2,1	3,3
140	Single-leaf	2,5	3,3	2,5	3,3	2,0	3,3
190	Collar-jointed	3,4	3,3	3,4	3,3	2,7	3,3
220	Collar-jointed	4,0	3,3	4,0	3,3	3,1	3,3
<b>Hollow units</b>							
90	Single-leaf	1,4	3,3	1,4	3,3	1,2	3,0
90-90	Cavity	2,1	3,3	2,1	3,3	1,8	3,3
110	Single-leaf	2,0	3,3	2,0	3,3	1,8	3,3
110-110	Cavity	2,6	3,3	2,6	3,3	2,0	3,3
140	Single-leaf	2,5	3,3	2,5	3,3	1,8	3,0
190	Single-leaf	3,4	3,3	3,4	3,3	2,4	3,3
NOTE See figure 11 for definitions of <i>L</i> and <i>H</i> .							

**Table 15 — External panel in framed housing units supported on one side with a movement joint at the top**

1	2	3	4	5	6	7	8	9	10	11	12	13	14
Nominal wall thickness mm	Wall type	Panel A No openings m				Panel B Openings ≤ 15 % wall area m				Panel C Openings > 15 % wall area m			
		L, max.	H	L	H, max.	L, max.	H	L	H, max.	L, max.	H	L	H, max.
<b>Solid units</b>													
90-90	Cavity	5,5	2,7	4,3	3,3	3,5	2,7	3,0	3,3	3,3	2,7	2,8	3,3
110-110	Cavity	7,0	3,3	7,0	3,3	7,0	2,7	4,8	3,3	5,8	2,7	4,2	3,3
190	Collar-jointed	8,0	3,3	8,0	3,3	8,0	3,3	8,0	3,3	8,0	3,3	8,0	3,3
220	Collar-jointed	9,0	3,3	9,0	3,3	9,0	3,3	9,0	3,3	9,0	3,0	9,0	3,3
<b>Hollow units</b>													
90-90	Cavity	4,0	2,7	3,0	3,3	2,5	2,7	2,1	3,3	2,9	2,7	2,0	3,3
110-110	Cavity	7,0	2,7	5,0	3,3	4,3	2,7	3,3	3,3	3,8	2,7	2,8	3,3
<p>NOTE 1 Two alternative panel sizes (<math>L \times H</math>) are provided in respect of each panel type. Linear interpolation is permitted between these two sets of panel dimensions but not between wall types.</p> <p>NOTE 2 The values given in respect of solid units may be used for corresponding walls of hollow unit construction provided that the following reinforcement is provided:</p> <p>a) truss-type brickforce (see figure 1) that has main wires of not less than 3,55 mm diameter built into courses at vertical centres that do not exceed 400 mm; and</p> <p>b) either two 5,6 mm diameter rods in each leaf of walls in the bed joint immediately above window level, or a single Y8 bar in a bond block in 140 mm and 190 mm single-leaf walls at this same level;</p> <p>such reinforcements extending across the entire length of the panel and into the supports.</p> <p>NOTE 3 See figure 11 for definitions of <math>L</math> and <math>H</math>.</p>													

## SANS 10400-K:2011

Edition 3

### 4.2.4 Free-standing boundary, garden and retaining walls

4.2.4.1 Free-standing retaining walls shall be designed and constructed so that

- a) the height of fill retained by free-standing retaining walls (see figure 17) does not exceed the values given in table 16, provided, however, that where  $x$  (see figure 17) exceeds 0,3 m, the height retained shall be reduced by the difference between  $x$  and 0,3 m,
- b) piers, where required in terms of table 16, project on the opposite side of the wall to the fill that is being retained,
- c) control joints are located at intervals that do not exceed 10 m,
- d) no surcharge of fill is placed within a distance equal to the height of the amount of fill being retained, and
- e) subsoil drainage is provided behind the wall by weepholes formed by building into the wall, and 50 mm diameter plastic pipes, with the non-exposed end covered with geofabric, at a height that does not exceed 300 mm above the lower ground level, and at centres that do not exceed 1,5 m.

**Table 16 — Retaining walls**

1	2	3	4	5
Nominal wall thickness ( $T$ ) mm	Wall type	Maximum height retained ( $h$ ) m	Nominal pier dimension (overall depth ( $D$ ) × width ( $W$ )) mm	Maximum centre to centre pier spacing m
<b>Solid units</b>				
140	Single-leaf	1,3	600 × 300	1,8
190	Collar-jointed	1,3	600 × 300	2,5
190	Collar-jointed	1,6	600 × 400	2,6
220	Collar-jointed	1,7	660 × 330	3,0
220	Collar-jointed	1,8	880 × 440	3,1
290	Collar-jointed	1,0	–	–
300	Collar-jointed	1,2	–	–
<b>Hollow units</b>				
140	Single-leaf	1,1	600 × 300	1,8
190	Single-leaf	1,1	600 × 300	2,5
190	Single-leaf	1,4	800 × 400	2,6

NOTE See figure 17 for plan and section of retaining walls.

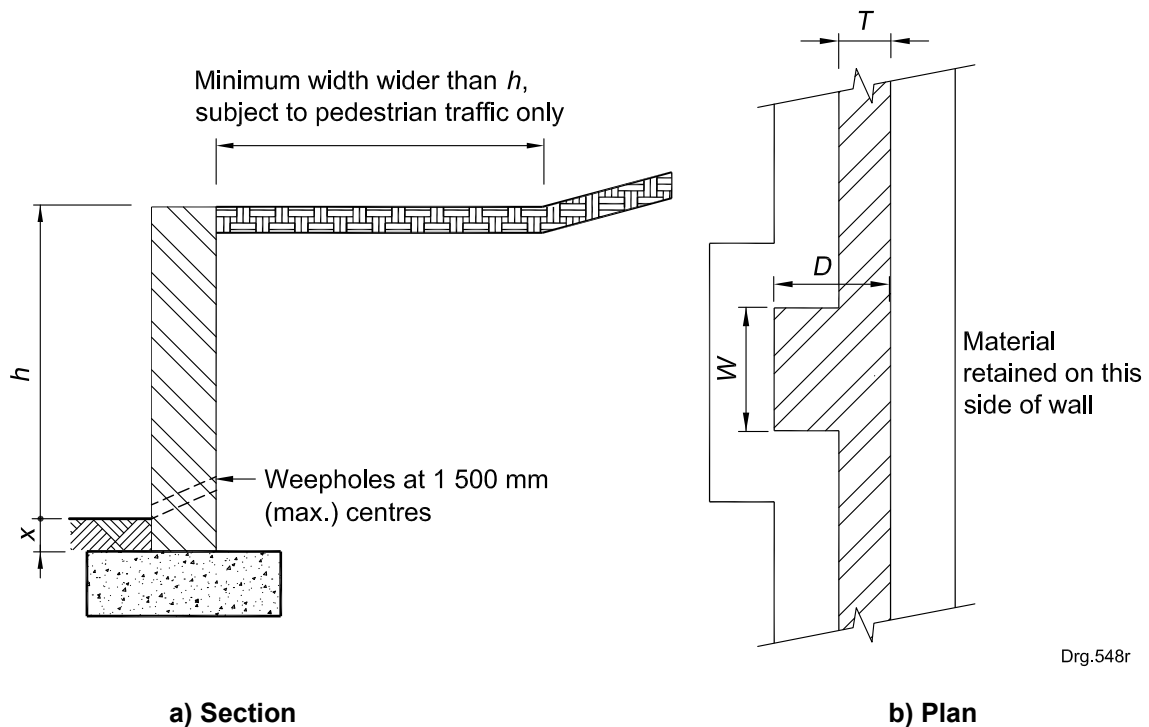

- $D$  = depth of pier
- $h$  = maximum height to be retained
- $T$  = thickness of wall
- $W$  = width of pier
- $x$  = height of soil above strip footing

**Figure 17 — Retaining walls**

**4.2.4.2** Free-standing boundary and garden walls shall be designed and constructed so that

- a) the height of the wall (see figure 18) does not exceed the values given in tables 17 and 18, provided however, that where  $x$  (see figure 18) exceeds 0,3 m, the height shall be reduced by the difference between  $x$  and 0,3 m,
- b) no earth is retained,
- c) piers extend to the top of the wall without any reduction in size,
- d) walls terminate in a pier or a return, and
- e) the cores of all piers are solidly filled with mortar or infill concrete where units are hollow.

**4.2.4.3** No horizontal damp-proof course (DPC) shall be provided in free-standing walls.

**SANS 10400-K:2011**

Edition 3

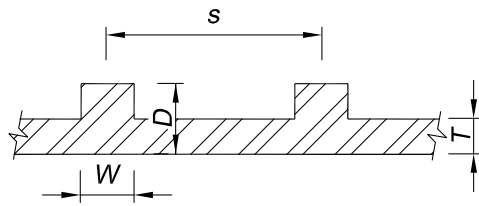

**a) Piers projecting on one side only**

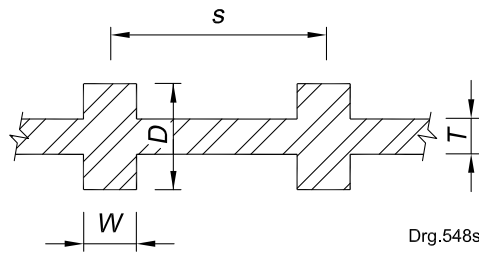

Drg.548s

**b) Piers projecting on both sides**

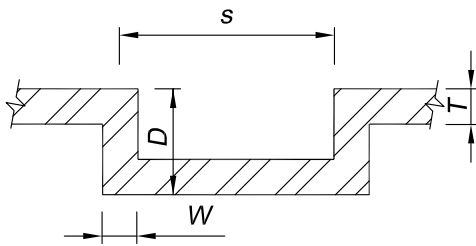

**c) Z-shaped walls**

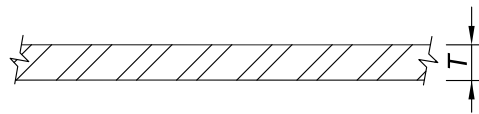

Drg.548t

**d) No piers**

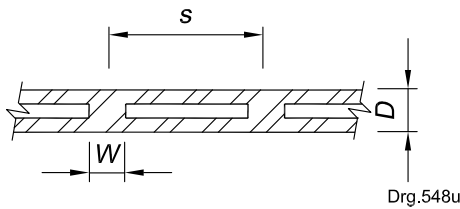

Drg.548u

**e) Diaphragm walls**

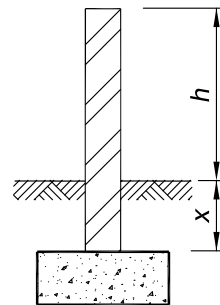

Drg.548ua

**f) Typical section through wall**

- $D$  = depth of pier
- $h$  = maximum height of wall above ground level
- $s$  = spacing of piers
- $T$  = thickness of wall
- $W$  = width of pier
- $x$  = height of soil above strip footing

**Figure 18 — Free-standing walls**



**Table 17 — Free-standing walls (solid units)**

1	2	3	4
Nominal wall thickness ( <i>T</i> ) mm	Maximum height above ground ( <i>h</i> ) m	Nominal dimensions of piers (overall depth ( <i>D</i> ) × width ( <i>W</i> )) mm	Maximum centre to centre pier spacing ( <i>s</i> ) m
<b>No piers</b>			
90	0,8	—	—
110	1,0	—	—
140	1,3	—	—
190	1,5	—	—
220	1,8	—	—
290	2,2	—	—
<b>Z-shaped walls</b>			
90	1,8	390 × 90	1,2
90	2,0	490 × 90	1,4
110	1,6	330 × 110	1,5
110	2,1	440 × 110	1,5
140	2,2	440 × 140	2,0
140	2,5	590 × 140	2,5
190	2,1	390 × 190	2,5
190	2,5	490 × 190	3,0
220	2,4	440 × 220	3,0
220	2,8	550 × 220	4,0
<b>Piers projecting on one side</b>			
90	1,4	290 × 290	1,4
90	1,5	390 × 290	1,6
90	1,7	490 × 290	1,6
110	1,5	330 × 330	1,8
110	1,5	440 × 330	1,8
110	1,9	550 × 330	2,0
140	1,7	440 × 440	2,2
140	1,8	590 × 390	2,5
190	2,0	590 × 390	2,8
220	2,3	660 × 440	3,2
<b>Piers projecting on both sides</b>			
90	1,5	490 × 290	1,4
110	1,6	550 × 330	1,8
140	1,6	440 × 440	2,2
190	1,8	590 × 390	2,8
220	2,1	660 × 440	3,2
<b>Diaphragm walls</b>			
90	2,1	290 × 190	1,4
90	2,7	390 × 190	1,4
110	2,6	330 × 220	1,6

NOTE See figure 18 for different free-standing wall types.

## SANS 10400-K:2011

Edition 3

**Table 18 — Free-standing walls (hollow units)**

1	2	3	4
Nominal wall thickness ( <i>T</i> ) mm	Maximum height above ground ( <i>h</i> ) m	Nominal dimensions of piers (overall depth ( <i>D</i> ) × width ( <i>W</i> )) mm	Maximum centre to centre pier spacing ( <i>s</i> ) m
<b>No piers</b>			
90	0,8	–	–
140	1,2	–	–
190	1,4	–	–
<b>Z-shaped walls</b>			
90	1,6	390 × 90	1,2
90	1,8	490 × 90	1,4
140	1,8	440 × 140	2,0
140	2,1	540 × 140	2,2
190	2,3	590 × 190	2,8
<b>Piers projecting on one side</b>			
90	1,2	390 × 390	1,4
90	1,7	490 × 390	1,7
140	1,4	440 × 290	2,1
140	1,5	540 × 390	2,3
190	1,6	590 × 390	2,8
<b>Piers projecting on both sides</b>			
90	1,0	490 × 290	1,4
140	1,4	440 × 440	2,2
220	1,7	660 × 440	2,9
<b>Diaphragm walls</b>			
90	1,8	290 × 190	1,4
90	2,3	390 × 190	1,4

NOTE See figure 18 for different free-standing wall types.

### 4.2.5 Balustrade and parapet walls

**4.2.5.1** Balustrade and parapet walls shall not be less than 1,0 m in height unless unauthorized access of persons to the edge of a flat roof or similar structure is excluded by a physical barrier properly erected and monitored.

**4.2.5.2** Free-standing balustrade and parapet walls shall have a thickness of not less than the height of the wall above the base divided by

a) Solid units:

- 1) no DPC at base: 5,0
- 2) DPC at base: 4,5

b) Hollow units that have cores filled with infill concrete:

- 1) no DPC at base: 4,0
- 2) DPC at base: 4,0

**4.2.5.3** Balustrade and parapet walls that have returns which continue for a distance of at least 0,75 m from the external face of such walls or are fixed to columns at centres that do not exceed 3,5 m, shall have a thickness of not less than

a) solid units: 110 mm

b) hollow units: 140 mm

#### 4.2.6 Control joints

**4.2.6.1** The overall length of a wall between free ends or returns shall not exceed the limits derived from table 19, unless vertical control joints have been incorporated into such wall so that the distance between a free end or a return and a vertical control joint, and the distance between vertical control joints is within such limits.

**Table 19 — Maximum spacing between vertical control joints in walls**

1	2	3	4
Unit type	Moisture expansion %	Maximum length of wall between vertical control joints	
		Free-standing wall m	Buildings m
<b>Unreinforced masonry</b>			
Burnt clay	< 0,05 0,05 to 0,10 0,11 to 0,20	16 10 6	18 14 10
Concrete	—	5,0 to 7,0	8
<b>Masonry with bed joint reinforcement at vertical centres that do not exceed 450 mm</b>			
Burnt clay	< 0,05 0,05 to 0,10 0,11 to 0,20	6 12 8	18 16 12
Concrete	—	10	12
NOTE 1 SANS 227 contains a test procedure to establish the moisture expansion of burnt clay bricks.			
NOTE 2 In wall construction that comprises hollow masonry units, the placing of a single Y8 bar in bond beams at centres that do not exceed 1 200 mm (generally in the course below slabs, below sills, above windows and above doors and in the uppermost course) may be treated as equivalent to bed joint reinforcement.			

**4.2.6.2** A vertical control joint shall be provided where there is a storey height change in the height of the external walling and where setbacks produce a return on plan of less than 800 mm (see figure 19).

NOTE Control joints are not required to continue below ground floor level except at changes in level and in free-standing walls.

**4.2.6.3** Vertical control joints in free-standing walls shall be provided at the locations shown in figure 20 and shall extend to the top of the foundation.

**4.2.6.4** Vertical control joints shall comprise butt joints that extend across the full width of the masonry. Such joints in hollow units shall be in accordance with figure 21.

**4.2.6.5** The gap between adjacent surfaces in the butt joint shall

a) not exceed 12 mm where walls are constructed using concrete masonry units, and

b) be between 10 mm and 12 mm where walls are constructed using burnt clay masonry units.

## SANS 10400-K:2011

Edition 3

**4.2.6.6** Tied butt joints shall be in accordance with figure 7. Vertical control joints at the interface with concrete columns shall be formed in accordance with figures 12 and 13.

**4.2.6.7** Vertical control joints in external walls of buildings shall be designed and constructed to resist the penetration of rain to the interior of the building.

NOTE 1 The sealant should be applied against a firm backing in a manner which ensures that it is forced against the sides of the joint under sufficient pressure to obtain good adhesion. The backing material should be firm but resilient and should not adhere to or react with the sealant. The compressibility of the backing material or joint filler is the most critical factor in the design of an adequate joint. Flexible cellular polyethylene, cellular polyurethane or foam rubber are the most suitable materials. Hemp, soft (fibre) board, cork, semi-rigid foams and similar materials are not suitable and should not be used. Alternatively, a temporary filler may be used to keep the joint clean and true during construction. A permanent backing (for example, polyethylene cord) can, upon completion, be forced into the formed joint to provide a backing for the sealant.

NOTE 2 Attention should be paid to the geometry of the sealant in the joint. The joint geometry, expressed as a ratio of the width to depth of the sealant cross section, is related to the properties of the sealant. Generally, the width to depth ratios for elasto-plastic sealants should be between 2:1 and 1:1, i.e. the depth of the seal should not exceed the width of the joint which is being sealed. (Further particulars may be found in SANS 10249).

**4.2.6.8** A 10 mm horizontal control joint shall be provided between the top of internal and external walls of burnt clay masonry construction in framed buildings in accordance with figures 16 and 22.

**4.2.6.9** Shims shall be provided in shelf angle fixings (see figure 22) to ensure that the angle bears for its full height against the concrete and permits the angle to be aligned. The total thickness of the shims between the concrete surface and the angle shall not exceed 13 mm. Masonry shall bear for at least two-thirds of its width at the shelf angle.

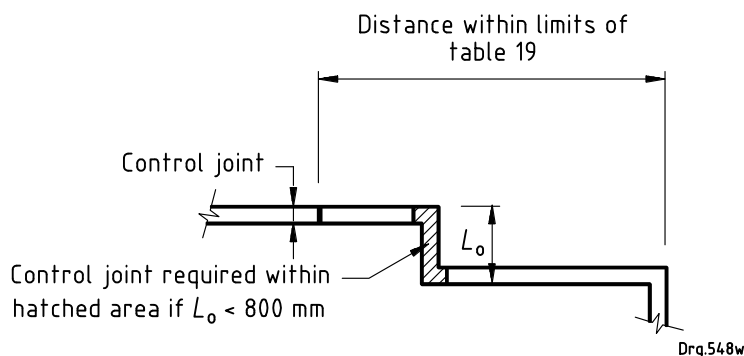
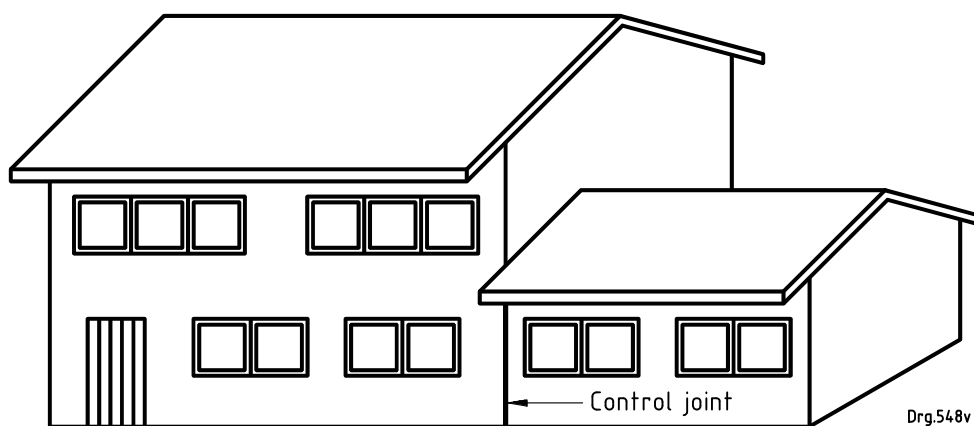

**Figure 19 — Location of control joints in buildings**

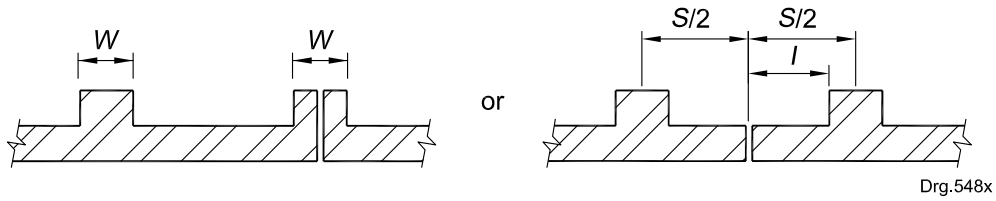

**a) Piers projecting on one side only**

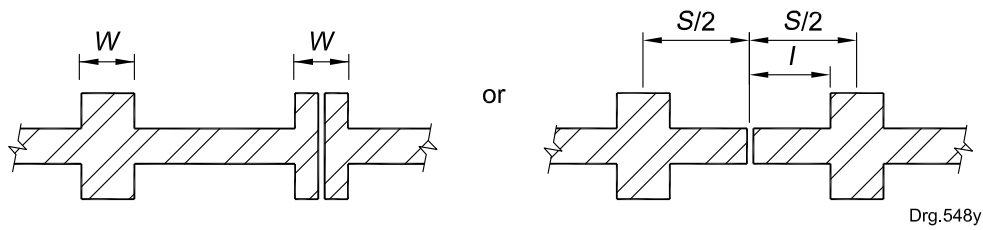

**b) Piers projecting on both sides**

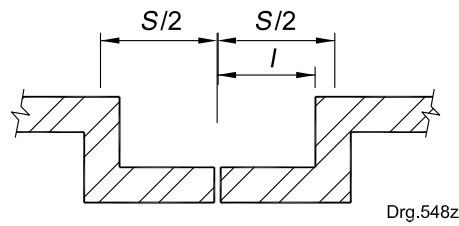

**c) Z-shaped walls**

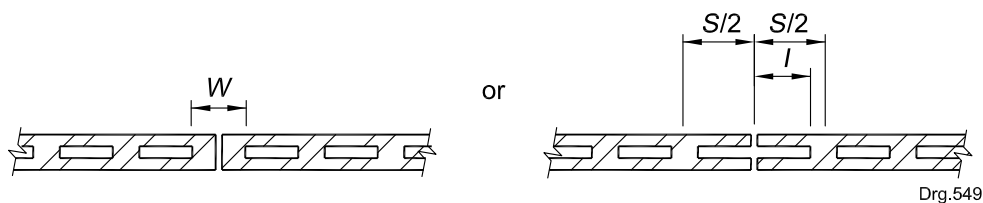

**d) Diaphragm walls**

Dimension  $l$  shall not exceed  $L$  derived from table 4 (panel supported on one side only).

**Figure 20 — Location of control joints in free-standing buildings**

**SANS 10400-K:2011**  
Edition 3

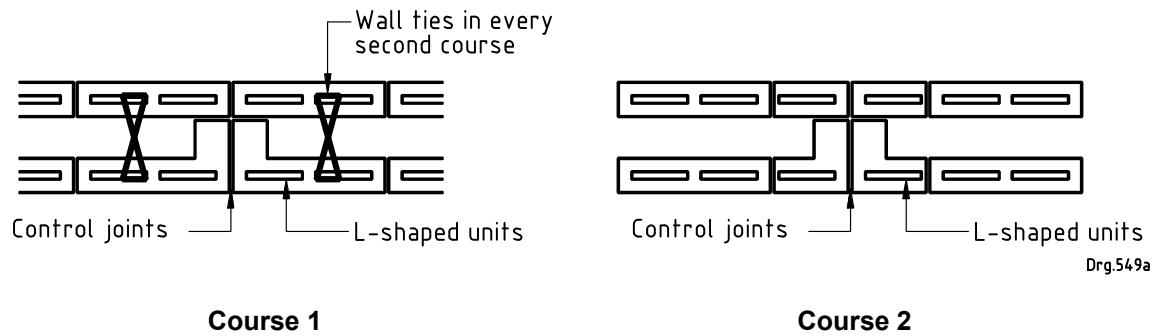

**a) Butt joint detail in cavity walls**

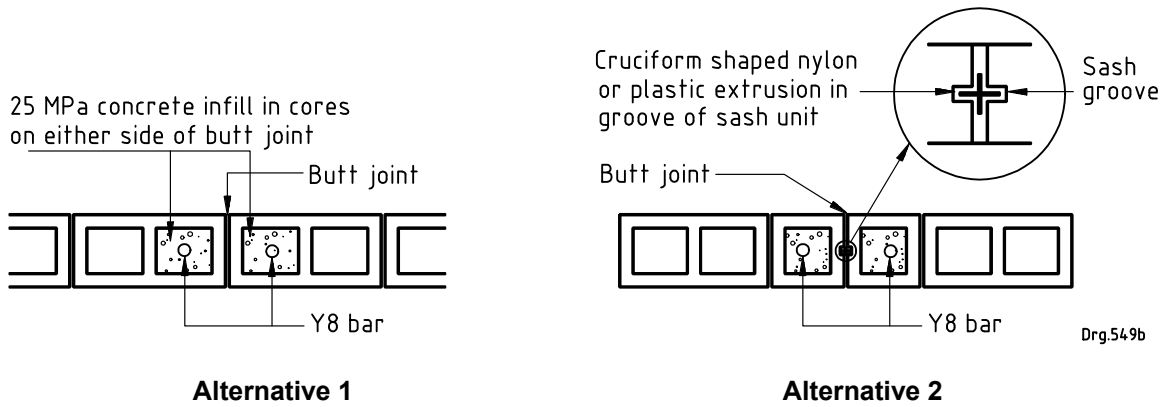

**b) Infill concrete in cores on either side of butt joint**

**Figure 21 — Butt joint details (no lateral stability)**

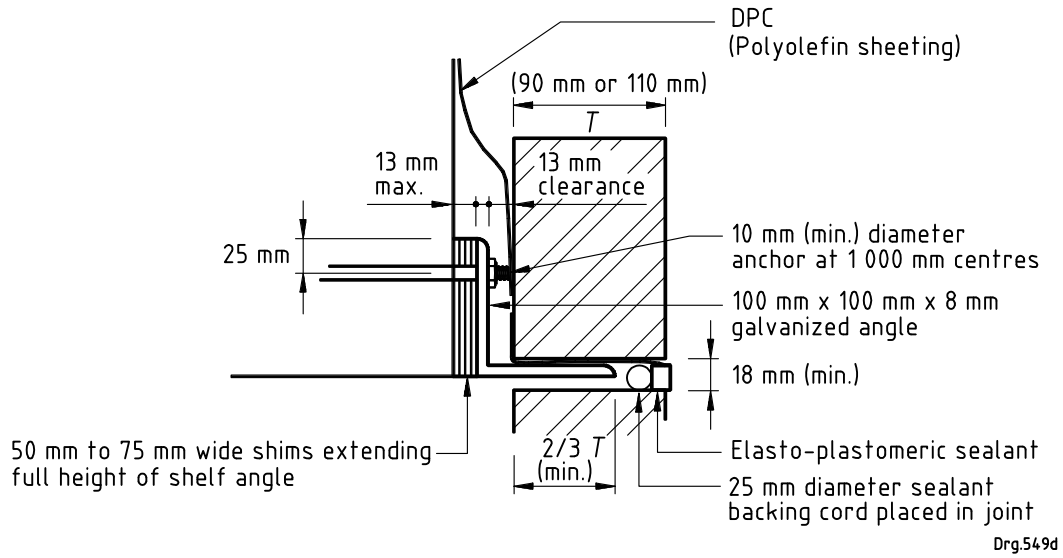

Height of wall shall not exceed 3,3 m.

**Section**

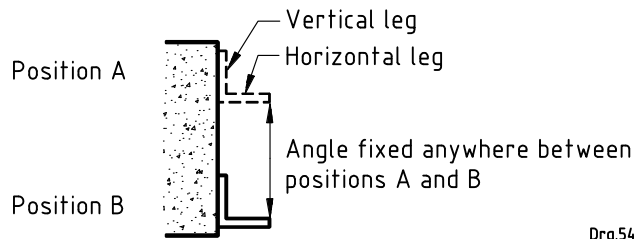

Vertical leg shall be above horizontal leg and not below.

**Location of shelf angle**

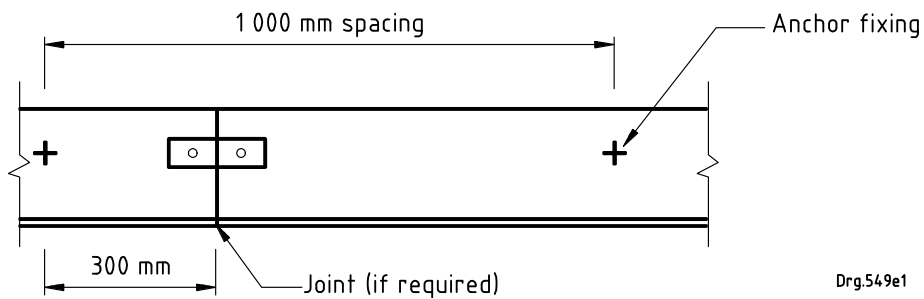

**Elevation**

**Figure 22 — Shelf angle details**

## **SANS 10400-K:2011**

Edition 3

### **4.2.7 Articulation joints**

**4.2.7.1** Articulation joints, where required, shall be capable of movement (expanding or contracting) to cater for the rigid body displacements of the walls as they rotate with the foundations. Joints shall be free of mortar droppings or other obstructions which might impede the function of the joints and, where required, shall be filled with a compressible filler and sealed with a sealant which is capable of withstanding the range of movements which are expected to take place.

NOTE 1 Articulation joints are required for modified normal construction on class C1, H1 and S1 sites which are designed in accordance with the requirements of SANS 10400-H.

NOTE 2 Articulation joints should be located at positions where concentrations or variations in the potential development of stress might occur, such as at changes in wall height; changes in wall thicknesses; and deep chases or rebates for service pipes.

**4.2.7.2** Articulation joints at doors and openings shall be in accordance with the requirements of figures 23, 24 and 25. Articulation joints at doors shall extend through the walls to the strip footings. Wall plates above articulation joints shall be cut, and arrangements shall be made to transfer loads from trusses located above doors to adjacent trusses by means of timber bearers (relief beams). Cornices shall either be fixed to the ceiling or to the walls, but not to both.

NOTE 1 Timber cornices are recommended as gypsum cornices tend to curl.

NOTE 2 When planning the position of internal articulation joints, cognizance should be taken of the location of wall returns (i.e. wall elements forming an L, Z or T-shape on plan) to ensure lateral stability of the walls.

### **4.2.8 Corbelling**

Where courses are corbelled out one above the other, the extent of corbelling shall not exceed that shown in figure 26.



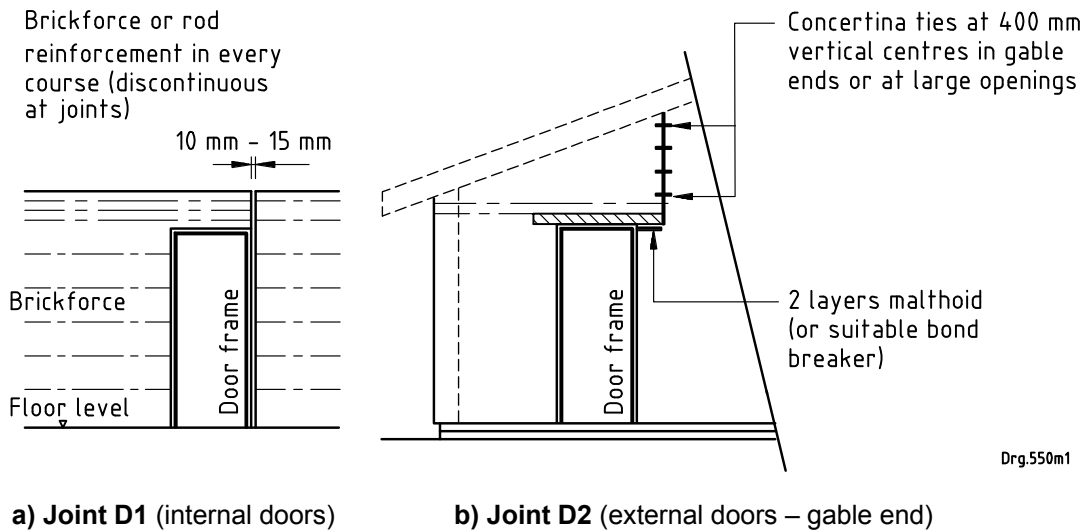

Drg.550m1

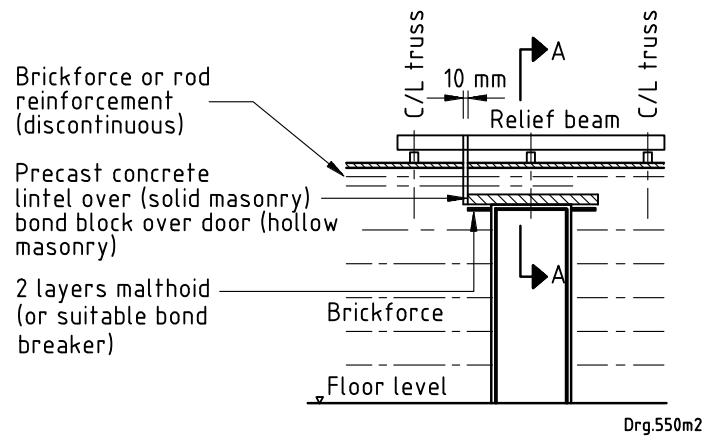

Drg.550m2

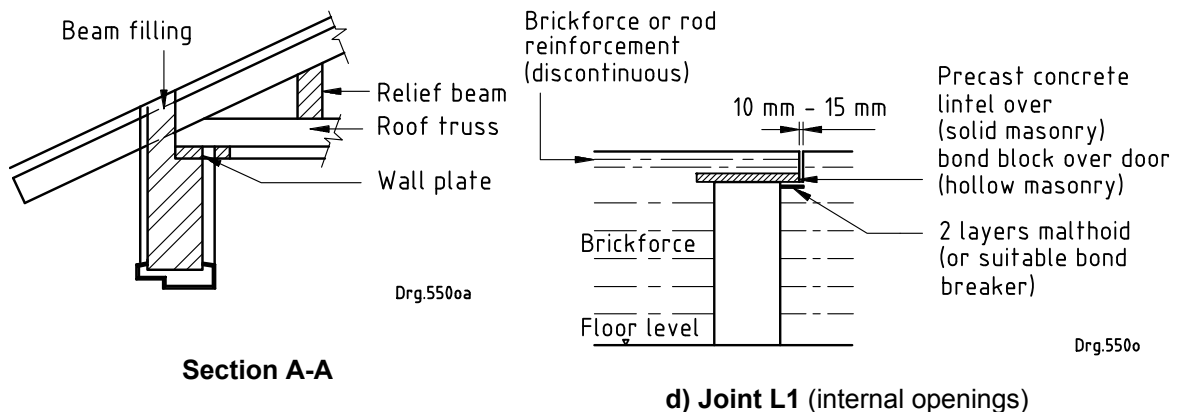

Drg.550oa

Drg.550o

Wall plate shall be cut at articulation joints.  
Door jamb details shall be in accordance with figure 25.

**Figure 23 — Articulation joints at doors and openings**

**SANS 10400-K:2011**  
Edition 3

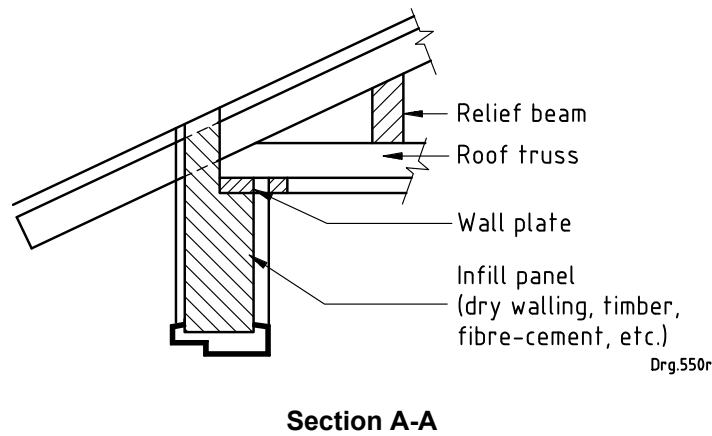
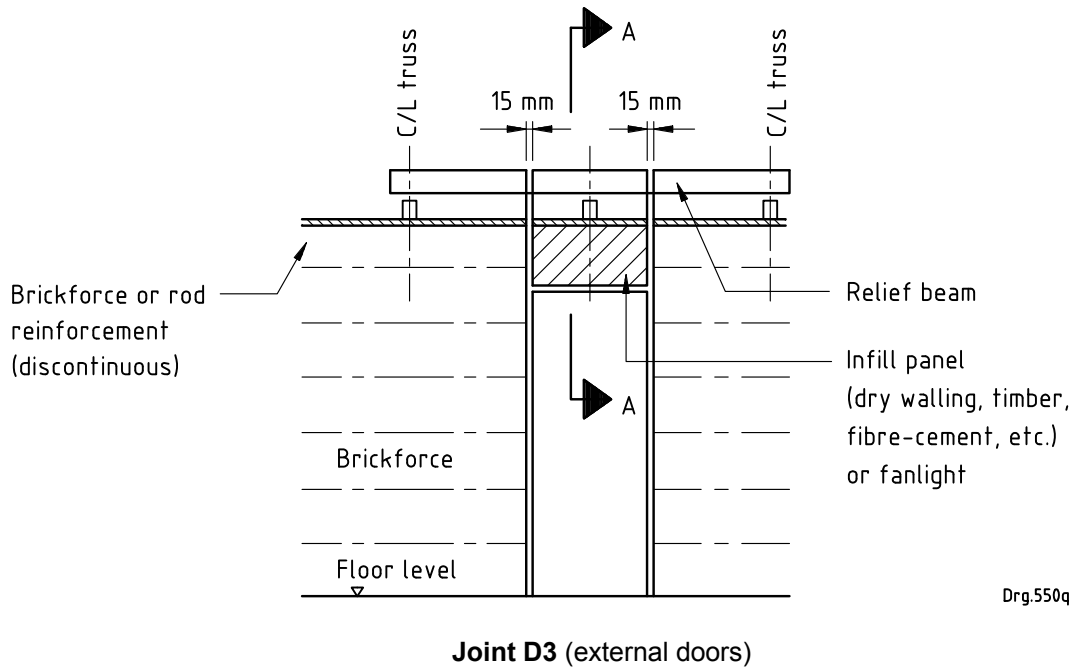

Wall plate shall be cut at articulation joints.  
Door jamb details shall be in accordance with figure 25.

**Figure 24 — Alternative articulation joints at doors and openings**

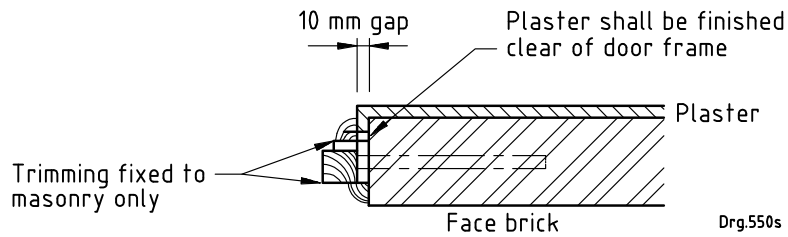

**a) Solid timber door frame<sup>a</sup>**

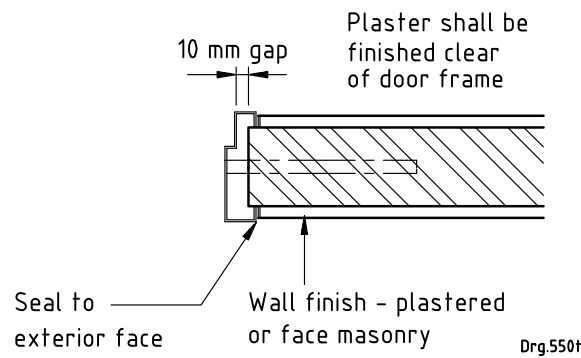

**b) Standard steel door frame<sup>a</sup>**

NOTE Lugs are bent into masonry.

<sup>a</sup> With a minimum of six number 25 lugs (0,8 mm × 350 mm long) per door jamb.

**Figure 25 — Details of articulation joints at door frames**

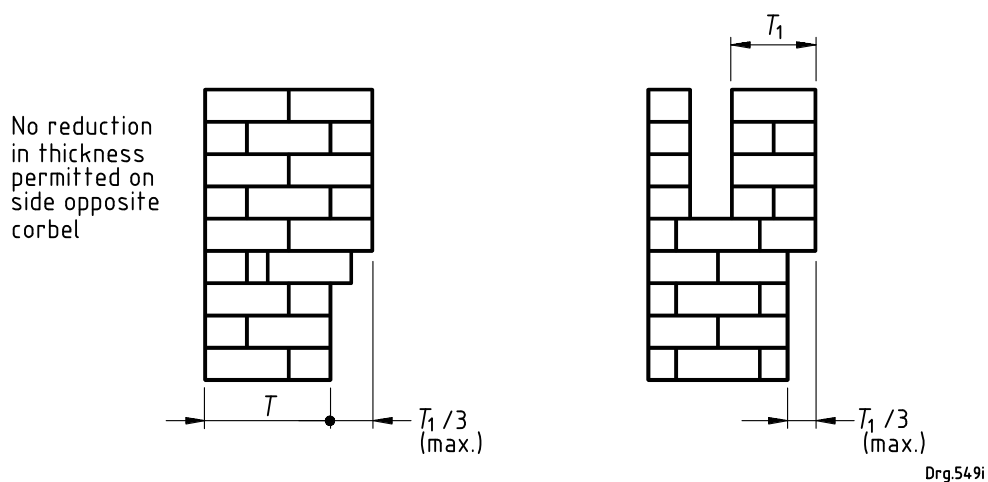

$T$  = wall thickness

**Figure 26 — Sizes of corbels**

## **SANS 10400-K:2011**

Edition 3

### **4.2.9 Lintels**

NOTE 1 Annex B provides information on the design of lintels and the minimum depths of lintels and maximum size of openings that can be accommodated using the tabulations provided in 4.2.9.

NOTE 2 In gable end construction, the minimum overall lintel depth or number of courses above the lintel soffit will be at the edge of the opening furthest from the apex.

#### **4.2.9.1 Bed joint reinforced lintels**

**4.2.9.1.1** Bed joint reinforced lintels shall have primary reinforcement located in the lowermost bed joints in accordance with table 20, 21 or 22 and secondary bed joint reinforcement in the uppermost bed joint in accordance with table 23 and in accordance with the details shown in figure 27.

NOTE Tables 20, 21 and 22 provide reinforcing details for lintels supporting tiled and sheeted roofs. Lintels which support concrete floors and roofs and timber floors fall outside the scope of this part of SANS 10400 and as such should be designed in accordance with the requirements of SANS 10400-B. Guidance on the design of lintels over openings is given in appendix G of the Joint Structural Division of the South African Institution of Civil Engineering and the Institution of Structural Engineers' *Code of practice for foundations and superstructures for single-storey residential buildings of masonry construction*, 1995.

**4.2.9.1.2** Masonry units in the lowermost course (course below the bed joint containing the reinforcement) shall either rest on the window or door frame below or, where practicable, be tied to the course above by means of crimp wire ties placed in cores or cavities or collar joints or perpend joints at centres that do not exceed 300 mm. Precast concrete lintels or lintel (U) blocks shall be used to form the bottom course in lintels where the soffit does not rest on a frame and the units cannot be tied to the course above by means of crimp wire ties.

**4.2.9.1.3** Brickforce shall be provided at centres that do not exceed 200 mm between the primary and secondary reinforcement described in 4.2.9.2.1 and 4.2.9.2.2, respectively.

**4.2.9.1.4** Primary reinforcement as described in 4.2.9.2.1 shall be located in the uppermost bed joint in accordance with the details shown in figure 28 where the pier between successive openings is less than 750 mm in width.

**4.2.9.1.5** The cores and perpend joints in hollow units shall be solidly filled with mortar or grade 10 concrete, as appropriate.

**4.2.9.1.6** Lapping of rod reinforcement shall not be permitted. The lap length in respect of brickforce shall not be less than 300 mm.

**4.2.9.1.7** Lintels shall be adequately supported for a period of not less than 7 d after completion.

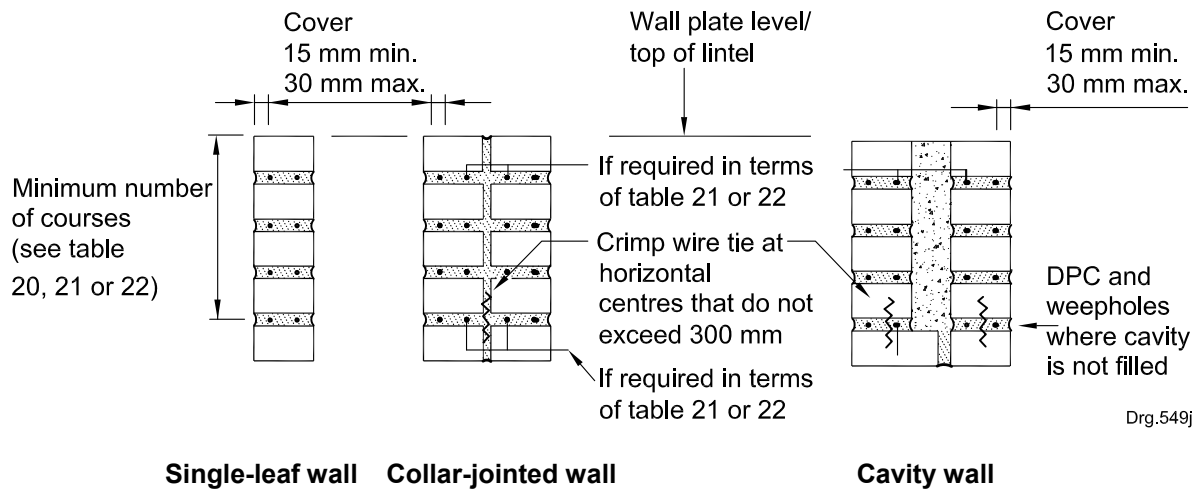

Drg.549j

**a) Typical section through lintel**

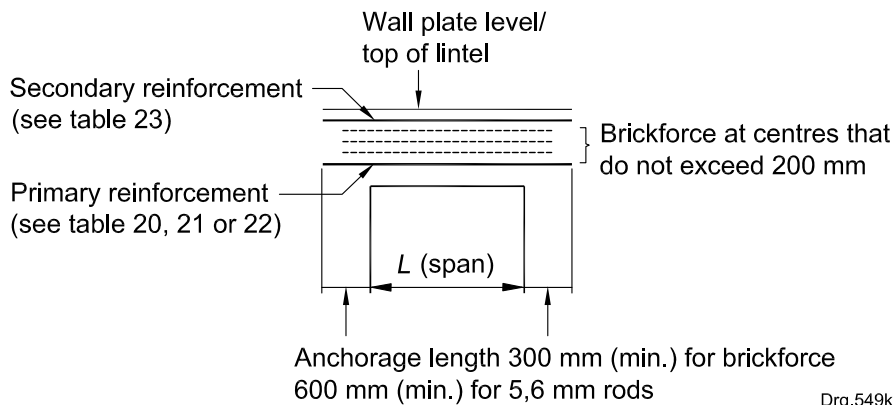

Drg.549k

**b) Single opening**

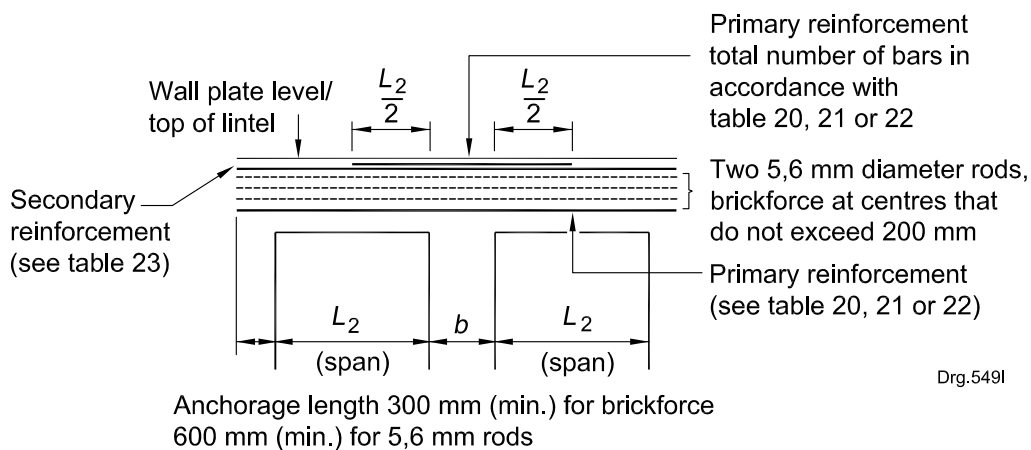

Drg.549l

**c) Openings with narrow pier where  $b < 750$  mm**

**Figure 27 — Bed joint reinforced lintel details**

**SANS 10400-K:2011**

Edition 3

**Table 20 — Primary bed joint reinforcement for lintels that do not support roofs or floors**

1	2	3	4	5
Minimum number of courses			Maximum span m	Rod reinforcement (number × diameter) mm
Course height mm				
85	100	200		
<b>90 mm single-leaf wall</b>				
–	3	–	2,5	2 × 5,6
4	–	–	3,0	2 × 5,6
5	4	2	3,0	2 × 5,6
<b>110 mm single-leaf wall</b>				
4	–	–	3,0	2 × 5,6
<b>140 mm single-leaf wall</b>				
–	3	–	2,5	2 × 5,6
4	–	–	3,0	2 × 5,6
5	4	2	3,0	2 × 5,6
<b>190 mm single-leaf/collar-jointed wall</b>				
–	3	–	2,5	2 × 5,6
4	–	–	3,0	2 × 5,6
5	4	2	3,5	2 × 5,6
<b>220 mm collar-jointed wall</b>				
4	–	–	3,0	2 × 5,6
5	4	2	3,5	2 × 5,6
<b>90 mm-90 mm cavity wall (cavity solidly filled)</b>				
–	3	–	2,5	2 × 5,6
4	–	–	3,0	2 × 5,6
5	4	2	3,0	2 × 5,6
<b>110 mm-110 mm cavity wall (cavity solidly filled)</b>				
4	–	–	3,0	2 × 5,6
NOTE 1 If the cavity in cavity wall construction is not filled with infill concrete, the two leaves should be considered independent leaves and be treated as single-leaf walls.				
NOTE 2 Bed joint reinforced lintel details are shown in figure 27.				

**Table 21 — Primary bed joint reinforcement for lintels that support light roofs**

1	2	3	4	5	6	7	8	9
Minimum number of courses			Maximum roof span					
Course height mm			m					
			4		6		8	
85	100	200	Maximum span m	Rod reinforcement (number × diameter) mm	Maximum span m	Rod reinforcement (number × diameter) mm	Maximum span m	Rod reinforcement (number × diameter) mm
<b>90 mm single-leaf wall</b>								
–	3	–	2,0	2 × 5,6	2,0	2 × 5,6	a	a
4	–	–	2,0	2 × 5,6	2,0	2 × 5,6	a	a
5	4	2	2,5	2 × 5,6	2,5	2 × 5,6	a	a
6	5	–	3,0	2 × 5,6	3,0	2 × 5,6	a	a
<b>110 mm single-leaf wall</b>								
4	–	–	2,0	2 × 5,6	2,0	2 × 5,6	a	a
5	–	–	2,5	2 × 5,6	2,5	2 × 5,6	a	a
6	–	–	3,0	2 × 5,6	3,0	2 × 5,6	a	a
<b>140 mm single-leaf wall</b>								
–	3	–	2,5	2 × 5,6	2,5	2 × 5,6	2,0	2 × 5,6
4	–	–	2,5	2 × 5,6	2,5	2 × 5,6	2,5	3 × 5,6
5	4	2	3,0	2 × 5,6	3,0	3 × 5,6	2,5	3 × 5,6
6	5	–	3,0	2 × 5,6	3,0	2 × 5,6	3,0	3 × 5,6
<b>190 mm collar-jointed wall</b>								
–	3	–	2,5	2 × 5,6	2,5	3 × 5,6	2,0	2 × 5,6
4	–	–	2,5	2 × 5,6	2,5	2 × 5,6	2,5	3 × 5,6
5	4	2	3,0	2 × 5,6	3,0	3 × 5,6	3,0	3 × 5,6
6	5	–	3,5	3 × 5,6	3,5	3 × 5,6	3,0	3 × 5,6
7	6	3	3,5	2 × 5,6	3,5	2 × 5,6	3,5	3 × 5,6
<b>220 mm collar-jointed wall</b>								
4	–	–	2,5	2 × 5,6	2,5	2 × 5,6	2,5	3 × 5,6
5	–	–	3,0	3 × 5,6	3,0	3 × 5,6	3,0	4 × 5,6
6	–	–	3,5	3 × 5,6	3,5	3 × 5,6	3,5	4 × 5,6
7	–	–	3,0	2 × 5,6	3,0	2 × 5,6	3,0	3 × 5,6
<b>90 mm-90 mm cavity wall (cavity solidly filled)</b>								
–	3	–	2,5	2 × 5,6	2,5	3 × 5,6	2,5	3 × 5,6
4	–	–	3,0	3 × 5,6	3,0	4 × 5,6	3,0	4 × 5,6
5	4	2	3,0	3 × 5,6	3,0	3 × 5,6	3,0	4 × 5,6
<b>110 mm-110 mm cavity wall (cavity solidly filled)</b>								
4	–	–	3,0	4 × 5,6	3,0	4 × 5,6	2,5	3 × 5,6
5	–	–	3,0	3 × 5,6	3,0	4 × 5,6	3,0	4 × 5,6

<sup>a</sup> Not permitted.

**SANS 10400-K:2011**

Edition 3

**Table 22 — Primary bed joint reinforcement for lintels that support heavy roofs**

1	2	3	4	5	6	7	8	9
Minimum number of courses			Maximum roof span					
Course height mm			m					
			4		6		8	
85	100	200	Maximum span m	Rod reinforcement (number × diameter) mm	Maximum span m	Rod reinforcement (number × diameter) mm	Maximum span m	Rod reinforcement (number × diameter) mm
<b>90 mm single-leaf wall</b>								
–	3	–	1,5	2 × 5,6	1,5	2 × 5,6	a	a
4	–	–	2,0	2 × 5,6	1,5	2 × 5,6	a	a
5	4	2	2,5	2 × 5,6	2,0	2 × 5,6	a	a
6	5	–	2,5	2 × 5,6	2,0	2 × 5,6	a	a
7	6	3	2,5	2 × 5,6	2,5	2 × 5,6	a	a
8	7	–	2,5	2 × 5,6	2,5	2 × 5,6	a	a
9	–	–	3,0	2 × 5,6	2,5	2 × 5,6	a	a
–	8	4	3,0	2 × 5,6	2,5	2 × 5,6	a	a
10	–	–	3,0	2 × 5,6	3,0	2 × 5,6	a	a
<b>110 mm single-leaf wall</b>								
4	–	–	2,0	2 × 5,6	1,5	2 × 5,6	a	a
5	–	–	2,5	2 × 5,6	2,0	2 × 5,6	a	a
6	–	–	2,5	2 × 5,6	2,5	2 × 5,6	a	a
7	–	–	2,5	2 × 5,6	2,5	2 × 5,6	a	a
8	–	–	3,0	2 × 5,6	2,5	2 × 5,6	a	a
9	–	–	3,0	2 × 5,6	3,0	2 × 5,6	a	a
10	–	–	3,0	2 × 5,6	3,0	2 × 5,6	a	a
<b>140 mm single-leaf wall</b>								
–	3	–	2,0	2 × 5,6	1,5	2 × 5,6	1,5	2 × 5,6
4	–	–	2,0	2 × 5,6	2,0	2 × 5,6	1,5	2 × 5,6
5	4	2	2,5	2 × 5,6	2,5	3 × 5,6	2,0	2 × 5,6
6	5	–	3,0	2 × 5,6	3,0	3 × 5,6	2,5	3 × 5,6
7	6	3	3,0	2 × 5,6	3,0	3 × 5,6	2,5	2 × 5,6
8	7	–	3,0	2 × 5,6	3,0	3 × 5,6	3,0	3 × 5,6
<b>190 mm collar-jointed wall</b>								
–	3	–	2,5	3 × 5,6	2,0	3 × 5,6	2,0	3 × 5,6
4	–	–	2,5	3 × 5,6	2,5	4 × 5,6	2,0	3 × 5,6
5	4	2	3,0	3 × 5,6	2,5	3 × 5,6	2,5	3 × 5,6
6	5	–	2,5	2 × 5,6	3,0	3 × 5,6	3,0	4 × 5,6
7	6	3	3,5	4 × 5,6	3,5	4 × 5,6	2,5	2 × 5,6
8	7	–	3,0	2 × 5,6	2,5	2 × 5,6	3,0	3 × 5,6
9	–	–	3,5	3 × 5,6	3,5	3 × 5,6	3,5	4 × 5,6
–	8	4	3,5	3 × 5,6	3,0	2 × 5,6	3,5	4 × 5,6
10	–	–	3,5	3 × 5,6	3,5	3 × 5,6	3,5	3 × 5,6
<sup>a</sup> Not permitted.								



**Table 22 (concluded)**

1	2	3	4	5	6	7	8	9
Minimum number of courses			Maximum roof span					
Course height mm			m					
			4		6		8	
85	100	200	Maximum span m	Rod reinforcement (number × diameter) mm	Maximum span m	Rod reinforcement (number × diameter) mm	Maximum span m	Rod reinforcement (number × diameter) mm
<b>220 mm collar-jointed wall</b>								
4	–	–	2,5	3 × 5,6	2,5	4 × 5,6	2,0	2 × 5,6
5	–	–	3,0	3 × 5,6	3,0	4 × 5,6	2,5	3 × 5,6
6	–	–	2,5	2 × 5,6	2,5	2 × 5,6	3,0	4 × 5,6
7	–	–	3,5	4 × 5,6	3,5	4 × 5,6	3,0	4 × 5,6
8	–	–	3,0	2 × 5,6	3,0	3 × 5,6	2,5	2 × 5,6
9	–	–	3,5	3 × 5,6	3,5	4 × 5,6	3,5	4 × 4,6
10	–	–	3,5	3 × 5,6	3,5	3 × 5,6	3,5	3 × 5,6
<b>90 mm-90 mm cavity wall (cavity solidly filled)</b>								
–	3	–	2,5	3 × 5,6	2,5	4 × 5,6	2,0	3 × 5,6
4	–	–	2,5	3 × 5,6	2,0	3 × 5,6	2,0	3 × 5,6
5	4	2	3,0	4 × 5,6	2,5	3 × 5,6	2,5	4 × 5,6
6	5	–	2,5	2 × 5,6	3,0	4 × 5,6	2,5	3 × 5,6
7	6	3	3,5	4 × 5,6	2,5	2 × 5,6	3,0	4 × 5,6
8	7	–	3,0	3 × 5,6	3,0	4 × 5,6	3,0	4 × 5,6
<b>110 mm-110 mm cavity wall (cavity solidly filled)</b>								
4	–	–	2,5	3 × 5,6	2,5	4 × 5,6	2,0	3 × 5,6
5	–	–	3,0	4 × 5,6	2,5	3 × 5,6	2,5	4 × 5,6
6	–	–	3,0	3 × 5,6	3,0	4 × 5,6	2,5	3 × 5,6
7	–	–	2,5	2 × 5,6	3,0	4 × 5,6	3,0	4 × 5,6
<p>NOTE 1 If the cavity in cavity wall construction is not filled with infill concrete, the two leaves should be considered independent leaves and be treated as single-leaf walls. Reinforcement for the leaf supporting the roof is determined in accordance with this table; reinforcement for the leaf not supporting any roof is determined in accordance with table 20.</p> <p>NOTE 2 Heavy roofs are roofs with the following finishes:</p> <p>a) concrete roof tiles;</p> <p>b) clay roof tiles;</p> <p>c) slates; or</p> <p>d) thatch.</p> <p>NOTE 3 Bed joint reinforced lintel details are shown in figure 27.</p>								
<p><sup>a</sup> Not permitted.</p>								

**SANS 10400-K:2011**

Edition 3

**Table 23 — Secondary bed joint reinforcement details for lintels**

1	2	3	4
Span m	Load		
	No roof	Light roof (metal profile sheeting, metal roof tiles, fibre-cement sheeting or fibre-cement slates)	Heavy roof (concrete roof tiles, clay roof tiles, slates or thatch)
<b>90 mm and 110 mm single-leaf wall</b>			
1,5	Brickforce	Brickforce	Brickforce
2,0	Brickforce	2 × 5,6 mm diameter	Brickforce
2,5	2 × 5,6 mm diameter	2 × 5,6 mm diameter	2 × 5,6 mm diameter
3,0	2 × 5,6 mm diameter	2 × 5,6 mm diameter	2 × 5,6 mm diameter
<b>140 mm single-leaf wall</b>			
1,5	Brickforce	Brickforce	Brickforce
2,0	Brickforce	Brickforce	Brickforce
2,5	Brickforce	2 × 5,6 mm diameter	Brickforce
3,0	2 × 5,6 mm diameter	2 × 5,6 mm diameter	2 × 5,6 mm diameter
<b>190 mm and 220 mm collar-jointed wall</b>			
1,5	Brickforce	Brickforce	Brickforce
2,0	Brickforce	Brickforce	Brickforce
2,5	Brickforce	2 × 5,6 mm diameter	Brickforce
3,0	Brickforce	2 × 5,6 mm diameter	Brickforce
3,5	Brickforce	2 × 5,6 mm diameter	Brickforce
<b>90 mm-90 mm and 110 mm-110 mm cavity wall (cavity solidly filled)</b>			
1,5	Brickforce	Brickforce	Brickforce
2,0	Brickforce	Brickforce	Brickforce
2,5	Brickforce	2 × 5,6 mm diameter	Brickforce
3,0	Brickforce	2 × 5,6 mm diameter	Brickforce
NOTE 1 If the cavity in a cavity wall construction is not filled with infill concrete, the two leaves should be considered independent leaves and be treated as single-leaf walls.			
NOTE 2 Bed joint reinforced lintel details are shown in figure 27.			

**4.2.9.2 Bond block lintels**

**4.2.9.2.1** Lintels constructed by means of bond blocks and lintel (U) blocks shall have primary reinforcement located in the block in the bottom course in accordance with tables 24, 25 or 26, as relevant, and in accordance with the details shown in figures 28 and 29.

NOTE Tables 24 to 26 provide reinforcing details for lintels supporting tiled and sheeted roofs. Lintels which support concrete floors and roofs and timber floors fall outside of the scope of this part of SANS 10400 and should be in accordance with the requirements of SANS 10400-B.

**4.2.9.2.2** Lintels shall have the following secondary reinforcement provided in the uppermost bed joint:

- a) spans up to 1,5 m: brickforce
- b) spans greater than 1,5 m: truss-type reinforcement that has main wires not less than 3,55 mm in diameter

Alternatively, a bond block or lintel block reinforced with a single Y8 bar may be used instead of brickforce in the uppermost bed joint.

**4.2.9.2.3** The cores of hollow units immediately adjacent to openings shall be reinforced with a single Y10 bar that extends from floor level to the top of the lintel (see figure 29) and shall be solidly filled with grade 25 infill concrete.

**4.2.9.2.4** The cores and perpend joints of units shall be solidly filled with grade 25 infill concrete, as appropriate.

**4.2.9.2.5** Lintels shall be adequately supported for a period of not less than 7 d after completion.

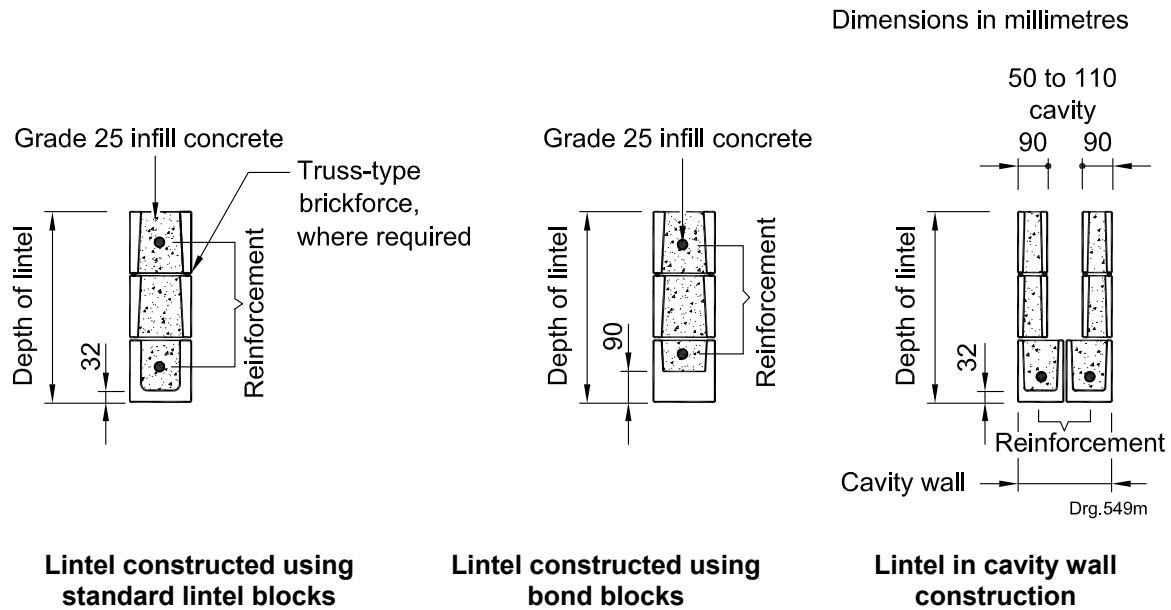

**a) Types of lintel blocks**

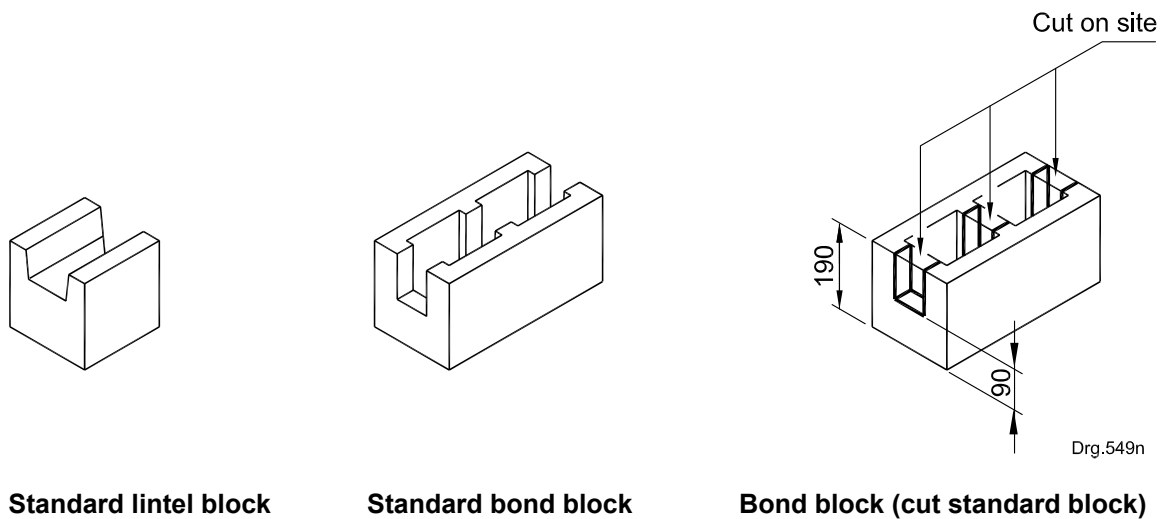

**b) Types of blocks**

NOTE Laps in reinforcement are permitted within a quarter span.

**Figure 28 — Bond and lintel block details**

**SANS 10400-K:2011**  
Edition 3

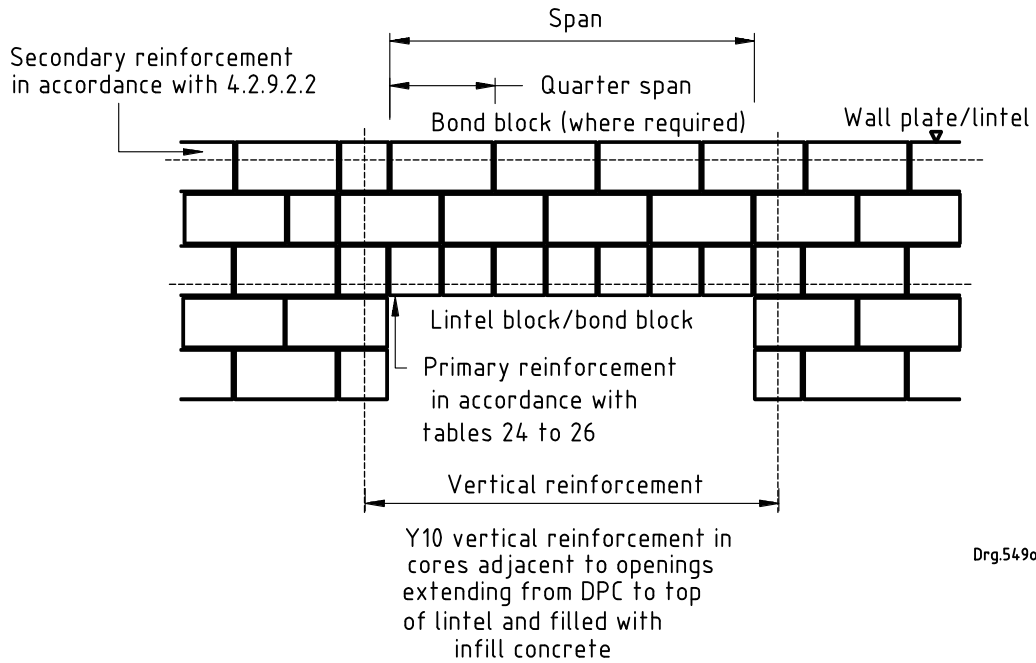

**a) Single opening**

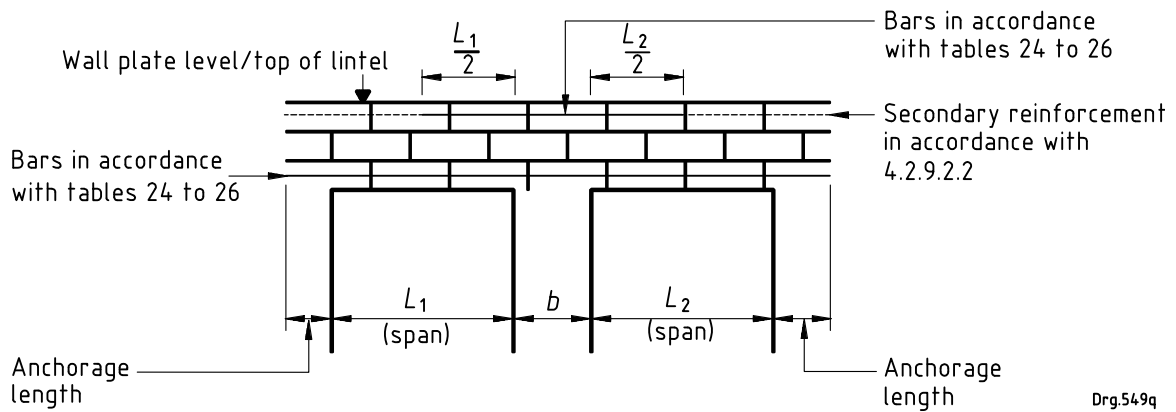

**b) Openings with narrow piers where  $b < 750$  mm**

**Figure 29 — Bond-block lintel details — Openings**

**Table 24 — Bond-block lintels that do not support roofs or floors**

1	2	3
Maximum width of opening m	Minimum overall lintel depth mm	Bond-block reinforcement (number × bar details)
<b>140 mm single-leaf wall</b>		
3,0	400	1 × Y8
3,0	600	1 × Y10
<b>140 mm-140 mm bond beam in cavity wall construction</b>		
3,0	400	1 × Y8
3,0	600	1 × Y8
3,0	800	1 × Y8
<b>190 mm single-leaf wall</b>		
3,0	400	1 × Y8
3,5	600	1 × Y8
3,5	800	1 × Y10

**Table 25 — Bond-block lintels that support light roofs**

1	2	3	4
Maximum width of opening m	Minimum overall lintel depth mm	Maximum roof span m	Bond-block reinforcement (number × bar details)
<b>140 mm single-leaf wall</b>			
1,5	400	8	1 × Y8
2,5	400	6	1 × Y8
3,0	600	8	1 × Y10
<b>140 mm-140 mm bond beam in cavity wall construction</b>			
1,5	400	8	1 × Y8
2,5	600	8	1 × Y8
3,0	800	8	1 × Y8
<b>190 mm single-leaf wall</b>			
2,0	400	8	1 × Y8
3,0	600	8	1 × Y10
3,5	600	6	1 × Y10
3,5	800	8	1 × Y12
Truss-type reinforcement that has main wires not less than 3,55 mm diameter shall be provided in the uppermost bed joint if a bond-block beam does not form the uppermost course where the span exceeds 1,5 m.			
NOTE 1 The values given in respect of 140 mm single-leaf walls may be used where the cavity in the 140 mm-140 mm bond beam in cavity construction is solidly filled with infill concrete.			
NOTE 2 Light roofs are roofs with the following finishes:			
a) metal profile sheeting;			
b) metal roof tiles;			
c) fibre-cement sheeting; or			
d) fibre-cement slates.			

**SANS 10400-K:2011**

Edition 3

**Table 26 — Bond-block lintels that support heavy roofs**

1	2	3	4
Maximum width of opening m	Minimum overall lintel depth mm	Maximum roof span m	Bond-block reinforcement (number × bar details)
<b>140 mm single-leaf wall</b>			
1,5	400	8	1 × Y8
2,0	400	6	1 × Y10
2,5	600	8	1 × Y10
3,0	600	6	1 × Y10
3,0	600	8	1 × Y12
<b>140 mm-140 mm bond beam in cavity wall construction</b>			
1,0	400	8	1 × Y8
1,5	400	6	1 × Y8
2,0	600	8	1 × Y8
2,5	600	6	1 × Y8
3,0	800	8	1 × Y8
<b>190 mm single-leaf wall</b>			
1,5	400	8	1 × Y8
2,0	400	6	1 × Y10
2,5	600	8	1 × Y10
3,0	600	8	1 × Y12
3,5	600	6	1 × Y10
3,5	800	8	1 × Y12
Truss-type reinforcement that has main wires not less than 3,55 mm in diameter shall be provided in the uppermost bed joint if a bond-block beam does not form the uppermost course where the span exceeds 2,5 m.			
NOTE 1 The values given in respect of 140 mm single-leaf walls may be used where the cavity in the 140 mm-140 mm beam in cavity construction is solidly filled with infill concrete.			
NOTE 2 Heavy roofs are roofs with the following finishes:			
a) concrete roof tiles;			
b) clay roof tiles;			
c) slates; or			
d) thatch.			

**4.2.9.2.6** Reinforcement may be lapped at the quarter spans; the length of such laps shall not be less than

a) Y10: 550 mm

b) Y12: 660 mm

c) Y16: 880 mm

**4.2.9.2.7** The side and top cover to reinforcement shall not be less than 30 mm.

**4.2.9.2.8** Where the width of piers between adjacent openings is less than 750 mm, an additional bond beam shall be placed in the uppermost course that has the same reinforcement as would have been the case had it been a single opening. In such cases, the reinforcement in the bond beam immediately above the opening shall be not less than that given in tables 24 to 26, as appropriate. The upper bond-block beam shall be continuous across the pier and extend across at least one-half of the length of the openings on either side of the pier. (See figure 29.)

#### **4.2.9.3 Precast prestressed concrete lintels**

**4.2.9.3.1** Precast prestressed concrete lintels, which comply with the relevant requirements of SANS 1504, may be built into walls compositely with masonry in accordance with table 27 and figure 30.

**4.2.9.3.2** Prestressed concrete lintels that do not comply with the requirements of SANS 1504 may be used as soffits to bed joint reinforced lintels and shall be reinforced in accordance with the requirements of 4.9.2.1.

NOTE Prestressed concrete lintels that do not comply with the requirements of SANS 1504, may be used as "non-structural" lintels. Such lintels are regarded as being a series of masonry units which merely replace the bottom course of masonry.

**4.2.9.3.3** Secondary reinforcement in accordance with table 23 shall be provided in the uppermost bed joint.

**4.2.9.3.4** Where the width of piers between openings is less than 750 mm, primary reinforcement in accordance with table 20, 21 or 22, as relevant, shall be provided in the uppermost bed joint, in accordance with figure 27.

**4.2.9.3.5** Lintels shall be set in mortar and have a minimum bearing of

- a) lintel that supports masonry only: 150 mm
- b) lintel that supports roof trusses of
  - 1) span less than or equal to 1,5 m: 150 mm
  - 2) span between 1,5 m and 2,5 m: 250 mm
  - 3) span greater than or equal to 2,5 m: 350 mm

#### **4.2.9.4 Double garage openings**

**4.2.9.4.1** Lintels over double garage openings which do not exceed 5,0 m shall be reinforced in accordance with figures 31 and 32 and table 28.

**4.2.9.4.2** Cores and cavities shall be filled with grade 25 infill concrete.

**4.2.9.4.3** Lintels shall be adequately supported for a period of not less than 7 d after completion.

**4.2.9.4.4** Reinforcement may be lapped at the quarter spans; the length of such laps shall not be less than

- a) Y10: 550 mm
- b) Y12: 660 mm
- c) Y16: 880 mm

**4.2.9.4.5** The side cover shall be not less than 30 mm.

**4.2.9.4.6** The cores of any hollow units immediately adjacent to openings shall be reinforced with a single Y10 bar that extends from the floor level to the top of the lintel (see figure 29) and shall be solidly filled with grade 25 infill concrete.

**SANS 10400-K:2011**

Edition 3

**4.2.9.4.7** Where the width of piers between adjacent openings is less than 750 mm, the primary reinforcement, as given in table 28 shall be provided at the top of the lintel and extend across at least half of the length of the openings on either side of the pier. (See figure 32.)

**Table 27 — Prestressed concrete lintels that comply with the requirements of SANS 1504**

1	2	3	4
Minimum number of courses above the prestressed lintel	Maximum span m		
	No roof	Light roof	Heavy roof
<b>85 mm course height: nominal width ≤ 140 mm</b>			
4	3,0	2,0	1,5
5	3,0	2,5	2,0
6	3,0	3,0	2,5
9	3,0	3,0	3,0
<b>85 mm course height: nominal width ≥ 190 mm</b>			
4	3,0	2,0	2,0
5	3,5	2,5	2,5
6	3,5	3,5	3,0
9	3,5	3,5	3,5
<b>100 mm course height: nominal width ≤ 140 mm</b>			
3	3,0	2,0	1,5
4	3,0	2,5	2,0
5	3,0	3,0	2,5
8	3,0	3,0	3,0
<b>100 mm course height: nominal width ≥ 190 mm</b>			
3	2,5	2,0	2,0
4	3,0	2,5	2,0
5	3,5	3,5	3,0
8	3,5	3,5	3,5
<p>NOTE 1 Light roofs are roofs with the following finishes:</p> <p>a) metal profile sheeting;</p> <p>b) metal roof tiles;</p> <p>c) fibre-cement sheeting; or</p> <p>d) fibre-cement slates.</p> <p>NOTE 2 Heavy roofs are roofs with the following finishes:</p> <p>a) concrete roof tiles;</p> <p>b) clay roof tiles;</p> <p>c) slates; or</p> <p>d) thatch.</p>			



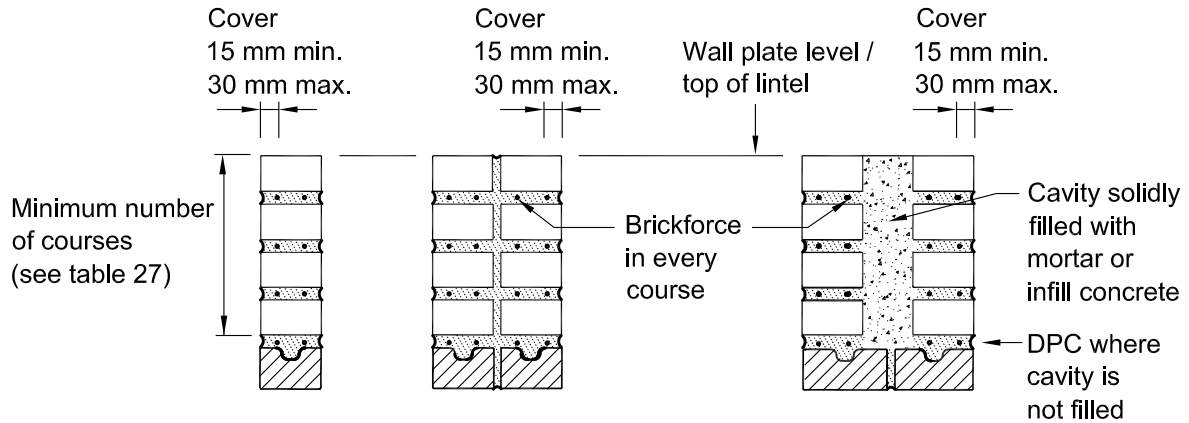

Drg.549r

**a) Section through lintels**

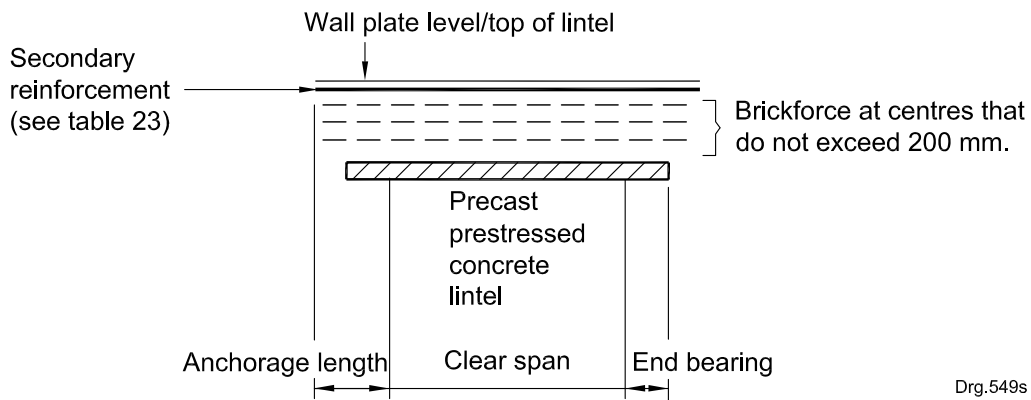

Drg.549s

**b) Single opening**

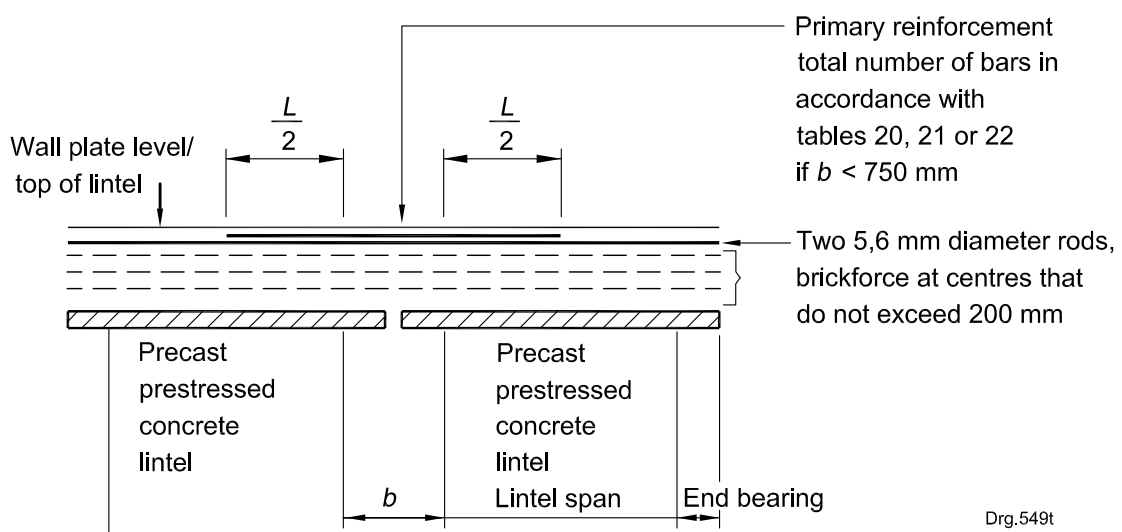

Drg.549t

**c) Multiple openings with narrow pier where  $b < 750$  mm**

**Figure 30 — Precast prestressed concrete lintels**

**SANS 10400-K:2011**  
Edition 3

**Table 28 — Lintels over double garage openings that have a clear opening that does not exceed 5,0 m**

1	2	3	4
Lintel type	Minimum lintel depth mm	Primary reinforcement (number × bar details)	Application
190 mm hollow block	600 800 800 1 000	2 × Y10 2 × Y12 2 × Y12 2 × Y12	No roof loads Light roof loads up to 8,0 m Heavy roof loads up to 6,0 m Heavy roof loads up to 8,0 m
2 × 140 mm hollow blocks combined with grouted cavity wall construction	600 800 800 1 000	2 × Y12 2 × Y12 2 × Y12 2 × Y16	No roof loads Light roof loads up to 8,0 m Heavy roof loads up to 6,0 m Heavy roof loads up to 8,0 m
Grouted cavity wall construction	595/600 700 765/800 935/1 000	2 × Y12 2 × Y12 2 × Y12 2 × Y16	No roof loads Light roof loads up to 8,0 m Heavy roof loads up to 6,0 m Heavy roof loads up to 8,0 m

NOTE 1 Light roofs are roofs with the following finishes:  
a) metal profile sheeting;  
b) metal roof tiles;  
c) fibre-cement sheeting; or  
d) fibre-cement slates.

NOTE 2 Heavy roofs are roofs with the following finishes:  
a) concrete roof tiles;  
b) clay roof tiles;  
c) slates; or  
d) thatch.

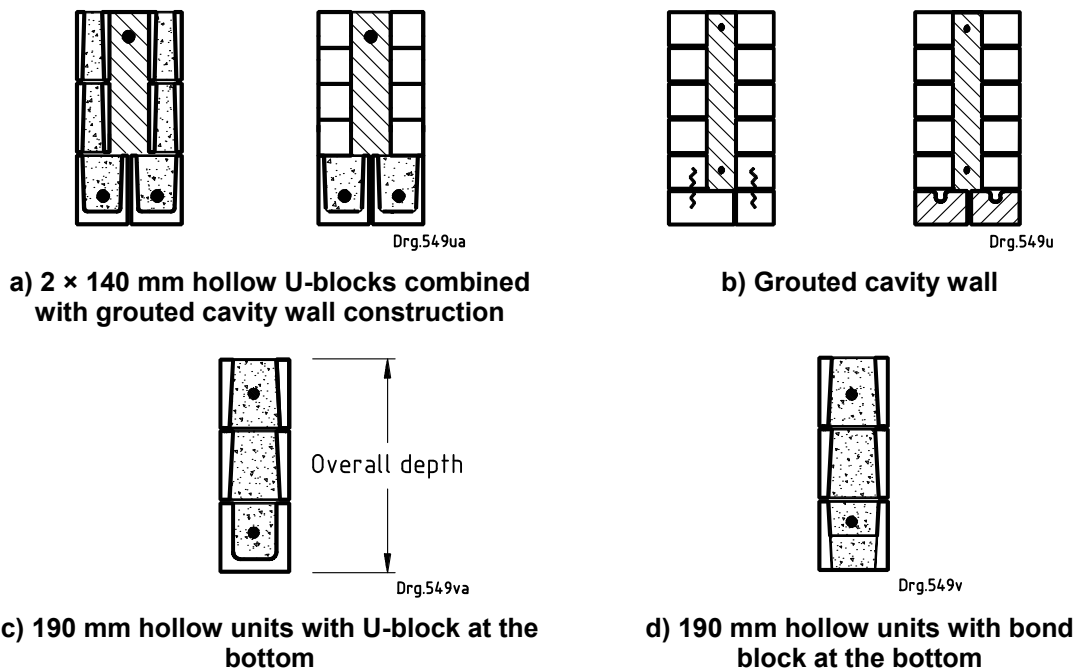

NOTE There is a 30 mm cover to reinforcement at the top of the lintel.

**Figure 31 — Lintels over double garage openings**

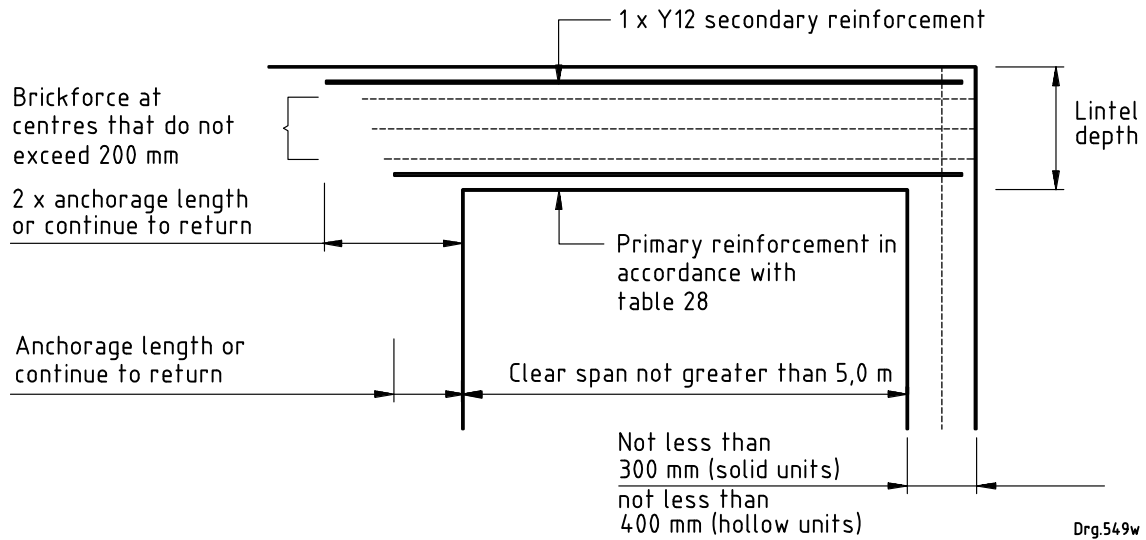

**a) Single opening**

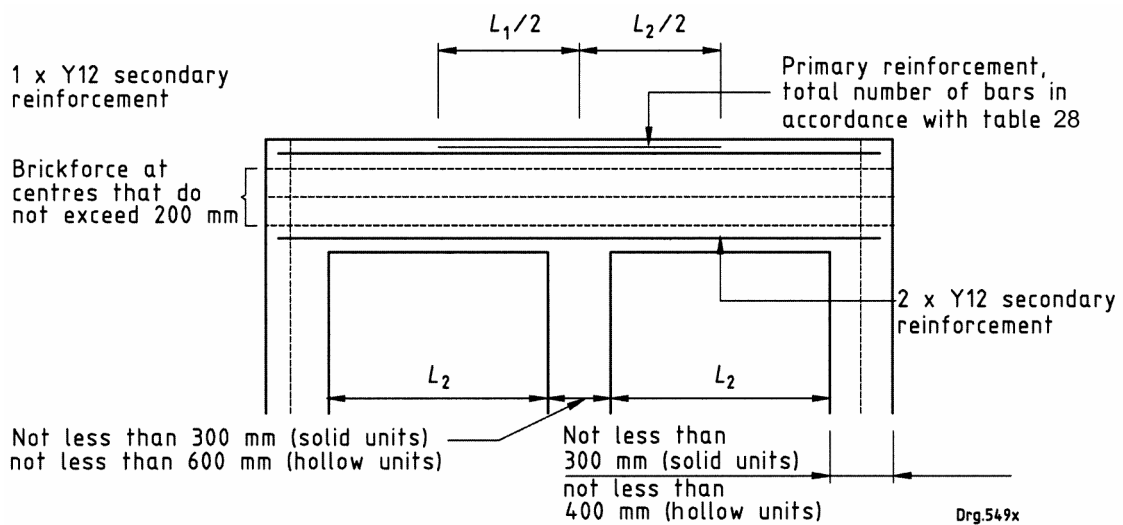

**b) Multiple openings**

Laps in reinforcement shall be permitted within a quarter span.

Anchor length:

Y10: 550 mm (min.)

Y12: 660 mm (min.)

Y16: 880 mm (min.)

**Figure 32 — Lintel details over double garage openings**

## SANS 10400-K:2011

Edition 3

### 4.2.10 Masonry arches

Circular masonry arches that have a span that does not exceed 2,5 m shall have an arch ring depth and proportions as shown in figure 33. Such arches shall be constructed as follows:

- a) The rise shall be between 0,3 and 0,5 times the span.
- b) Masonry units shall be solid.
- c) The arch ring shall be constructed in either a header or a stretcher pattern.
- d) The arch ring depth shall be
  - 1) not less than 200 mm where the rise is between half and two-thirds of the radius,
  - 2) not less than 300 mm where the rise is greater than two-thirds but less than or equal to the radius.

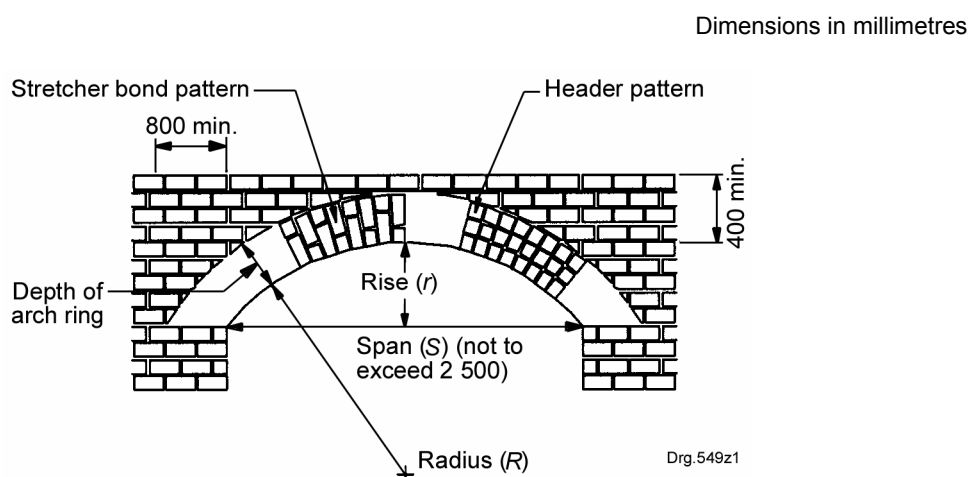

$$S = 2 \times \sqrt{2Rr - r^2}$$

**Figure 33 — Masonry arches**

### 4.2.11 Roof fixing

**4.2.11.1** Timber roof trusses, rafters and similar structures shall be fixed to walls by means of the following anchor types, selected in accordance with table 29:

- a) Type A: two strands of 2,4 mm diameter galvanized steel wire
- b) Type B: 30 mm × 1,2 mm galvanized steel strap
- c) Type C: 30 mm × 1,6 mm galvanized steel strap

**4.2.11.2** In the case of a wall of concrete or a wall erected with masonry units, the galvanized steel strap or wires shall be embedded in the wall at positions suitable for anchoring any timber roof truss, rafter or beam to such wall. Such anchors, where practicable, shall extend to a depth not less than that specified in table 30.

**4.2.11.3** Roof anchors shall be anchored in masonry in accordance with figures 34 and 35. The depth of embedment in mortar of hoop-iron straps in bed joints shall be not less than 70 mm.

**Table 29 — Roof anchor selection**

1	2	3	4
Roof slope degrees	Maximum roof truss/rafter spacing mm	Type of anchor required	
		Light roof	Heavy roof
< 15	760 1 050 1 350	A, B or C B or C C	
15 to 30	760 1 050 1 350	A, B or C B or C C	A for all applications
> 30	Any	A, B or C	
Wire shall not be permitted for lightweight roof coverings unless the truss/rafter spacing is 760 mm maximum. (This spacing would be very unusual.)			
NOTE 1 Light roofs are roofs with the following finishes: a) metal profile sheeting; b) metal roof tiles; c) fibre-cement sheeting; or d) fibre-cement slates.			
NOTE 2 Heavy roofs are roofs with the following finishes: a) concrete roof tiles; b) clay roof tiles; c) slates; or d) thatch.			

**Table 30 — Minimum depth of anchor embedment**

1	2	3
Roof type	Description of wall	Minimum depth of anchor embedment mm
<b>Solid units</b>		
Heavy	All wall types	300
Light	All wall types	600
<b>Hollow units</b>		
Heavy	All wall types	400
Light	• 90 mm and 110 mm single-leaf walls:	600
	• 90 mm-90 mm and 110 mm-110 mm cavity walls:	
	– cavity not filled above openings; span < 6,0 m	600
	– cavity filled above openings; span < 8,0 m	600
	• 140 mm and 190 mm single-leaf walls:	
– span < 6,0 m	600	
– span < 8,0 m	1 000	

**SANS 10400-K:2011**  
Edition 3

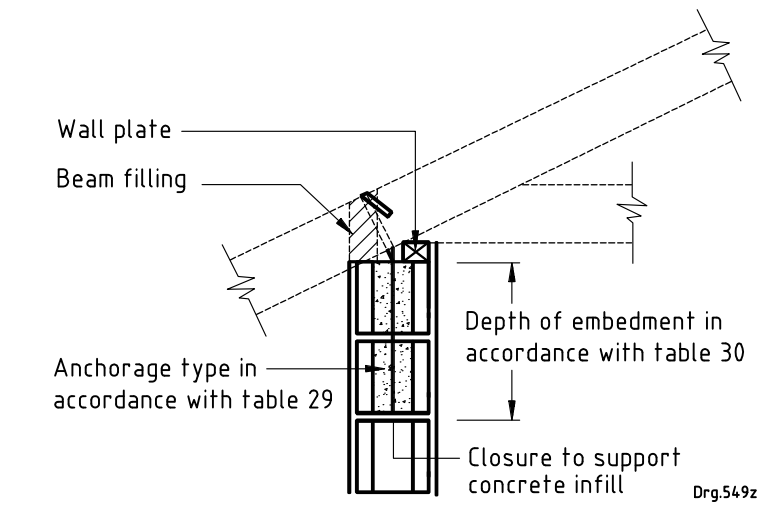

**a) Single-leaf wall**

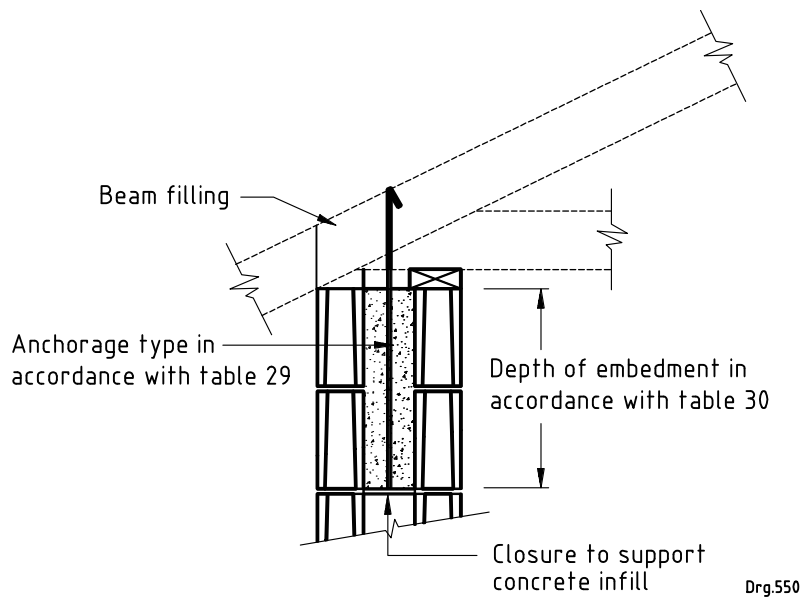

**b) Filled cavity wall**

**Figure 34 — Roof truss anchor details (hollow units)**

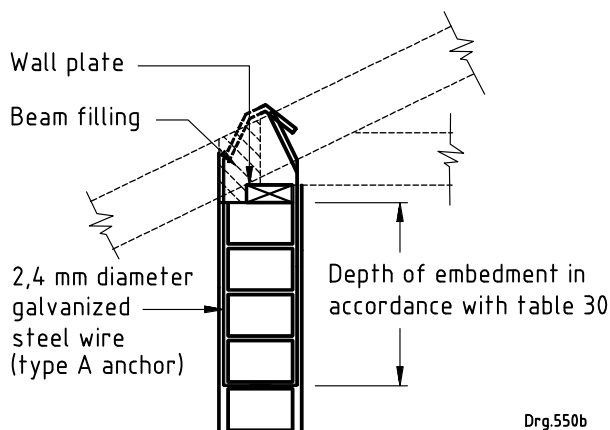

**a) Type A anchor**

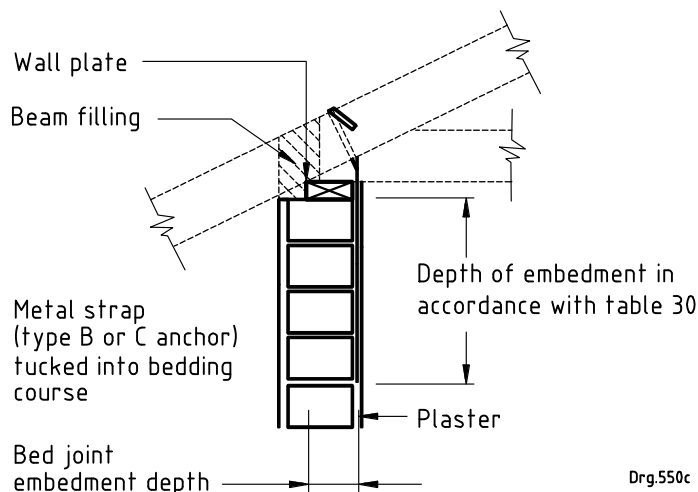

**b) Type B or C anchor**

Bed joint embedment depth:

a) Type A (wire): 100 mm

b) Type B and C (metal strap): 70 mm

**Figure 35 — Roof truss anchor details (solid units)**

### 4.3 Timber-framed walls

Internal and external timber-framed walls and the anchoring of roofs to walls in timber-framed buildings shall be in accordance with the requirements of SANS 10082.

All timber (see subregulation **A13(b)**) used in timber-framed walls shall be preservative treated in accordance with SANS 10005, as relevant.

## **SANS 10400-K:2011**

Edition 3

### **4.4 Fixing of roofs to concrete elements**

**4.4.1** The fixing of timber roof trusses, rafters and similar elements that have a span that does not exceed 8,0 m to concrete walls and columns, shall be by means of the following anchor types, selected in accordance with table 29:

- a) Type A: two strands of 2,4 mm diameter galvanized steel wire
- b) Type B: 30 × 1,2 mm galvanized steel strap
- c) Type C: 30 × 1,6 mm galvanized steel strap

**4.4.2** The galvanized steel straps or wires shall be embedded in the wall at positions suitable for anchoring any timber roof truss, rafter or beam to such wall. Such anchors shall extend to a depth not less than that specified in table 30.

### **4.5 Water penetration**

#### **4.5.1 Condensation**

**4.5.1.1** The design and construction of the building envelope in the Southern Coastal Condensation Problem Area (see figure 36) shall be such that

- a) the thermal performance of a building other than a category 1 building is of a sufficient standard to ensure that it will not contribute significantly to the occurrence of condensation on the internal surfaces of external walls for extended periods of time during the cold winter months; and
- b) the thermal performance of a category 1 building can be upgraded to that of (a) without rebuilding the building, by means of the insulation of walls, the installation of ceilings, etc.

**4.5.1.2** Occupancy class H3 and H4 buildings in the Southern Coastal Condensation Problem Area (see figure 36) shall provide a level of thermal performance at least equivalent to that of the Standard Agrément South Africa Comparative House (see figure 37) for a building of similar orientation, size, layout and fenestration as calculated by the simulation programme developed for Agrément South Africa.

**NOTE 1** The standard Agrément South Africa Comparative House comprises 230 mm solid masonry walls, which are plastered internally, concrete surface beds and a sheeted roof that is fitted with a ceiling without insulation.

**NOTE 2** The condensation referred to is prolonged in nature and results in the absorption of moisture by interior wall surfaces and ceilings. This encourages and sustains mould growth on such surfaces, releasing spores into the indoor environment that can have a severe detrimental effect on the health of the occupants. The factors that give rise to such condensation include overcrowding, poor thermal performance of the wall and roof construction, inadequate ventilation, the use of paraffin or gas (or both) heating and cooking and the indoor washing and drying of laundry. All of these factors contribute to the generation of excessive water vapour in the indoor atmosphere, which condenses on walls and ceilings when the surface temperature falls below the dew point.

**NOTE 3** The Agrément South Africa assessment criteria for the condensation in buildings provides some basic explanations regarding condensation terminology and requirements. (See [www.agrement.co.za](http://www.agrement.co.za).) It should be noted that the standard house (see figure 37) is not immune from condensation problems.



## 4.5.2 Rain penetration

**4.5.2.1** The resistance of external walls to rain penetration shall either be in accordance with table 31 when tested in accordance with the requirements of annex C, or in accordance with the requirements of one of the following:

a) buildings other than category 1 buildings:

- 1) single-leaf, hollow unit, shell-bedded masonry walls that have a thickness of 140 mm or greater;
- 2) single-leaf, solidly bed-jointed masonry walls that have a thickness of 140 mm or greater plastered in accordance with the requirements of SANS 2001-EM1;
- 3) collar-jointed, solid unit, solidly bed-jointed masonry walls that have a thickness of 190 mm;
- 4) a masonry wall of cavity construction;
- 5) a timber-framed wall built in accordance with SANS 10082; or
- 6) a wall coated with a coating that is the subject of an Agrément certificate;

b) category 1 buildings which have no overhangs or an overhang that does not comply with the requirements of figure C.1:

- 1) masonry walls of thickness 140 mm or greater;
- 2) walls of thickness 90 mm or greater plastered in accordance with the requirements of SANS 2001-EM1;
- 3) a precast concrete wall that has a nominal thickness not less than 40 mm, provided that any joints in such wall are sealed; or
- 4) a wall coated with a coating that is the subject of an Agrément certificate; or

c) category 1 buildings which have overhangs in accordance with figure C.1:

- 1) masonry walls of thickness 90 mm or greater; or
- 2) a wall coated with a coating that is the subject of an Agrément certificate.

**Table 31 — Rain penetration acceptance criteria**

<b>Building category</b>	<b>Acceptance criteria when tested in accordance with the requirements of annex C</b>
Category 1	Moisture which penetrates the wall is of insufficient intensity to run down the wall onto the floor of the house.
Other than category 1	No damp patches are visible on the inside of the wall.

**4.5.2.2** Notwithstanding the requirements of 4.5.2.1, any local authority may, in areas of prolonged heavy wind-driven rain, require that any masonry external wall be a cavity wall or other jointed wall with the inner face of the outer leaf bagged and painted with two coats of a suitable sealant.

## **SANS 10400-K:2011**

Edition 3

**4.5.2.3** Water penetrating into the fabric or structure of the wall shall drain to the outside or dry out (or both) without causing any structural damage. In timber-framed construction no water shall penetrate the cavity.

### **4.5.3 Rising damp**

**4.5.3.1** Any wall or sleeper pier of a building shall be provided with damp-proofing and vapour barrier installations in such positions and to such an extent that will reliably protect the wall against rising damp and the interior of the building against ingress of moisture from abutting ground.

**4.5.3.2** Any material used as a damp-proof course shall comply with the relevant requirements contained in SANS 248, SANS 298 or SANS 952-1, or shall be the subject of an Agrément certificate if the product is not covered by these standards.

**4.5.3.3** In a masonry wall, a damp-proof course shall be installed

- a) at the level of the top of a concrete floor slab resting on the ground; or
- b) where applicable, below any ground floor timber beam or joist.

**4.5.3.4** In the case of a masonry cavity wall,

- a) each leaf of such wall shall be provided with its own damp-proof course which shall extend over the full thickness of such leaf, in which case the cavity shall extend 150 mm below the damp-proof course; or
- b) each leaf of such wall shall be covered by a membrane which extends across the cavity provided that the position of the membrane at the inner leaf is higher than its position at the outer leaf; and
- c) where necessary, weepholes to prevent build-up of water in the cavity shall be provided in the external leaf of every cavity wall, spaced not more than 1 m apart, in the masonry unit course immediately below the damp-proof course contemplated in (a) or in the masonry unit course immediately above the membrane contemplated in (b).

**4.5.3.5** In any timber-framed wall, a damp-proof course shall be installed between the bottom plate of the wall and any foundation wall or concrete floor slab.

**4.5.3.6** In the case of a solid masonry wall, or timber-framed wall, the damp-proof course shall extend over the full thickness of such wall.

**4.5.3.7** No horizontal damp-proof course shall be installed less than 150 mm above the level of the adjacent finished ground.

**4.5.3.8** Transverse joints in the damp-proof course shall be overlapped to a minimum distance of 150 mm and at junctions and corners to a distance equal to the full thickness of the wall or the leaf, as the case might be.

**4.5.3.9** Where any part of any wall of a room is so situated that the ground will be in contact therewith, it shall be protected by a vertical waterproof membrane or by a drained cavity which shall extend below the level of the floor of such room. Drainage shall be provided at the base of such wall to prevent water accumulating there.

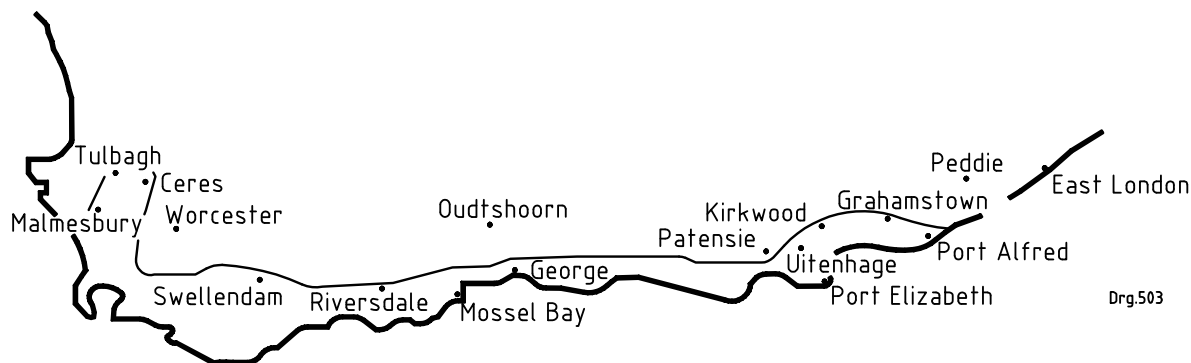

The SCCP area is readily identified by combining the following environmental features:

- It lies south of the major mountain ranges in the Southern Cape.
- It includes the area that receives winter and all-year-round rainfall.
- It receives an annual rainfall of between 250 mm and 500 mm per year.

**Towns that lie on the SCCP boundary**

Albertinia	Gouda	Katara	Prince Alfred	Swellendam
Alicedale	Grahamstown	Kirkwood	Riebeeck East	Tulbagh
Barrington	Greyton	Langholm	Riebeeck West	Uitenhage
Bathurst	Hamlet	Lindeshof	Riversdale	Villiersdorp
Blanco	Hankey	Louterwater	Riviersonderend	Wellington
Bluecliff	Heidelberg	Malmesbury	Ruiterbos	Wolseley
Ceres	Herbertsdale	Mamre	Stormsvlei	
Franschhoek	Joubertina	Paarl	Suurberg	
Genadendal	Kammiebos	Port Alfred	Suurbraak	

**Towns that lie within the SCCP area**

Addo	Dana Bay	Kalbaskraal	Papiesvlei	Stellenbosch
Alexandria	Despatch	Kareedouw	Paradise Beach	St Francis Bay
Amsterdampoek	Droë Vlakte	Kariega	Paterson	Still Bay
Askraal	Elgin	Kasuka	Pearly Beach	Storms River
Aston Bay	Elim	Kenton on Sea	Philadelphia	Strand
Atlantis	Fairfield	Kleinmond	Plettenberg Bay	Struis Bay
Baardskeerdersbos	Firgrove	Klipdale	Pniel	Sunland
Bellevue	Fish Hoek	Knysna	Port Beaufort	Swartkops
Bethelsdorp	Gans Bay	Kommetjie	Port Elizabeth	The Craggs
Betty's Bay	George	Kruisfontein	Protem	Vermaaklikheid
Bloubergstrand	Gordon's Bay	Kuilsrivier	Riethuiskraal	Viljoenskroon
Bluecliff	Gouritsmond	Kylemore	Rietpoel	Vlees Bay
Boesmansriviermond	Grabouw	Loerie	Rondevlei	Waenhuiskrans
Boknesstrand	Groot Brakrivier	Malgas	Salem	Wilderness
Botrivier	Groot	Melkbosstrand	Scarborough	Windmill
Brandwag	Jongensfontein	Milnerton	Sea View	Witsand
Bredasdorp	Hartenbos	Mossel Bay	Sedgefield	Wittedrif
Caledon	Hawston	Muizenberg	Simon's Town	Witteklip
Cape Town	Hermanus	Napier	Sinksabrug	Woodlands
Clarkson	Hermon	Noanaha	Skipkop	Wydgeleë
Coega	Herold's Bay	Onrus	Slangrivier	
Coerney	Hout Bay	Oukraal	Somerset West	
Colchester	Humansdorp	Oyster Bay	Southwell	
	Jeffreys Bay	Pacaltsdorp	Stanford	

**Figure 36 — The Southern Coastal Condensation Problem (SCCP) Area**

**SANS 10400-K:2011**

Edition 3

Dimensions in millimetres

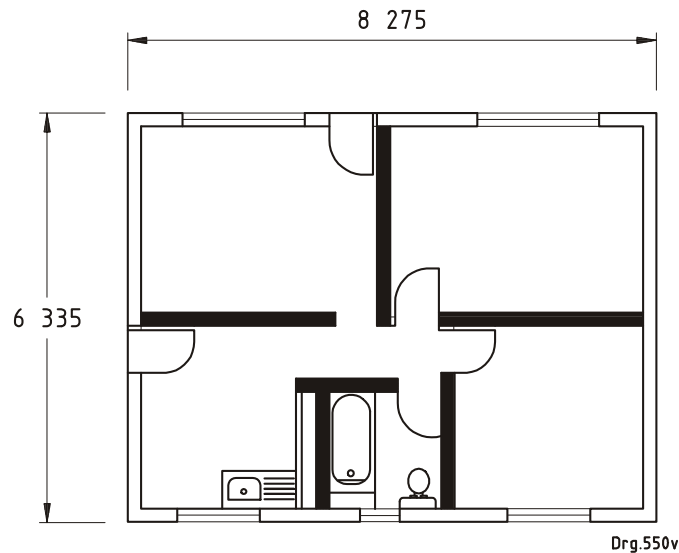
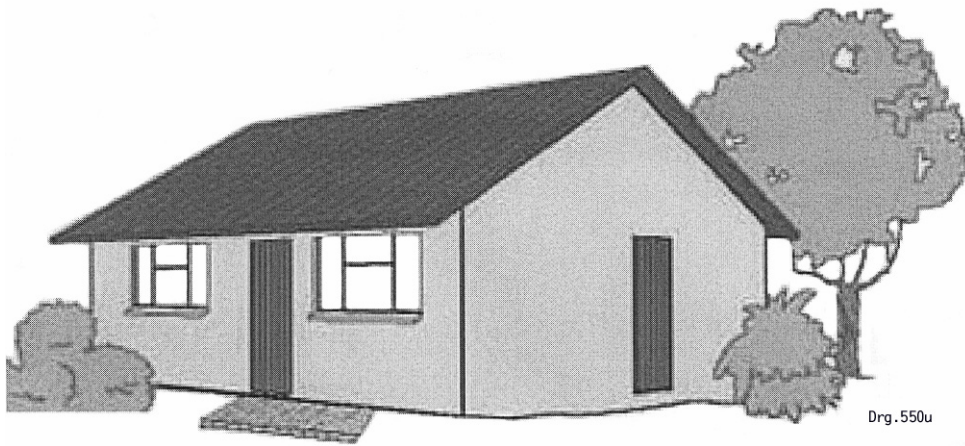

**Plan**

The window area does not exceed 15 % of the floor area.

The floor area is 53 m<sup>2</sup>.

The walls comprise 230 mm thick burnt clay masonry, plastered on both sides.

The floor comprises a concrete surface bed.

The house is orientated true north (i.e. predominant windows of the living area face true north, or the longer axis of the house runs as near east/west as possible).

**Figure 37 — Standard Agrément South Africa Comparative House used in condensation and thermal performance assessments**

## **4.6 Behaviour in fire**

**4.6.1** Walls in buildings other than single-storey category 1 buildings shall comply with the safety distances and fire-resistance requirements of 4.2 of SANS 10400-T:2011. Walls in single-storey category 1 buildings shall comply with the boundary and fire-resistance requirements of 4.57 of SANS 10400-T:2011.

**4.6.2** The fire performance and fire stability of walls shall be determined in accordance with the requirements of 4.5 and 4.7, respectively, of SANS 10400-T:2011.

**4.6.3** The fire resistance or non-combustibility of walls shall comply with the relevant requirements of the following subclauses of SANS 10400-T:2011:

- a) occupancy-separating and division-separating elements: 4.6
- b) tenancy-separating elements: 4.8
- c) partition walls and partitions: 4.9
- d) walls adjacent to openings within 1 m of a division: 4.10
- e) feeder routes: 4.18.1
- f) emergency routes: 4.19.1
- g) walls in service shafts: 4.40
- h) lift shafts in buildings of 10 storeys and more: 4.44
- i) stages and backstages: 4.48
- j) operating theatres and intensive care units: 4.51

**4.6.4** Wall finishes shall comply with the requirements of 4.15 of SANS 10400-T:2011.

**4.6.5** Walls in inaccessible concealed spaces and service shafts shall be fire-stopped in accordance with the requirements of 4.39 and 4.40, respectively, of SANS 10400-T:2011.

**4.6.6** Any services that penetrate or are recessed in walls in structural or separating elements shall be in accordance with the requirements of 4.41 of SANS 10400-T:2011.

## **SANS 10400-K:2011**

Edition 3

### **Annex A**

(informative)

## **National Building Regulations**

### **Part K: Walls**

#### **Definitions**

##### **structural wall**

wall forming part of any structural system

#### **Regulations**

##### **K1 Structural Strength and Stability**

Any wall shall be designed and constructed to safely sustain any actions which can reasonably be expected to occur and in such a manner that any local damage (including cracking) or deformation do not compromise the opening and closing of doors and windows or the weather tightness of the wall and in the case of any structural wall, be capable of safely transferring such actions to the foundations supporting such wall.

##### **K2 Water Penetration**

- (1) Any wall shall be so constructed that it will adequately resist the penetration of water into any part of the building where it would be detrimental to the health of occupants or to the durability of such building.
- (2) Where a building includes a basement or semi-basement, the local authority may, if it considers that conditions on the site on which the building is to be erected necessitate integrated designs for the penetration of water into such basement or semi-basement applicable to all construction elements or components thereof, require the submission of such designs for approval. Construction shall be in accordance with the requirements of the approved design.

##### **K3 Roof Fixing**

Where any roof truss, rafter or beam is supported by any wall provision shall be made to fix such truss, rafter or beam to such wall in a secure manner that will ensure that any actions to which the roof may normally be subjected will be transmitted to such wall.

##### **K4 Behaviour in Fire**

Any wall shall have combustibility and fire resistance characteristics appropriate to the location and use of such wall.

##### **K5 Deemed-to-Satisfy Requirements**

The requirements of regulations **K1**, **K2**, **K3** and **K4** shall be deemed to be satisfied where the structural strength and stability of any wall, the prevention of water penetration into or through such wall, the fixing of any roof to such wall and the behaviour in a fire of such wall, as the case may be, comply with SANS 10400-K.

## **Annex B** (informative)

### **Design of lintels**

#### **B.1 Introduction**

**B.1.1** Unreinforced masonry is weak in tension over openings. For this reason it is necessary to reinforce it. Primary or main reinforcement is required to reinforce masonry at the bottom of single openings and above the pier between openings in multiple openings, i.e. where tension forces develop. Secondary reinforcement (reinforcement of a smaller or equal bar diameter to that for primary reinforcement) is required in the uppermost course or bed joint to reinforce the masonry immediately above the face of the opening where some tension forces develop, particularly where lintels support light roofs.

**B.1.2** The strength of a masonry beam is generally dependent on its depth and the amount of tension reinforcement. The greater the beam depth, the greater is its strength. Deep sections of masonry also tend to arch across openings. It is therefore necessary to ensure that there are a minimum number of courses above an opening and that this section of masonry is reinforced appropriately.

#### **B.2 Designing lintels using standard designs**

**B.2.1** Figure B.1 outlines the process flow for the design of lintels in accordance with the requirements of 4.2.9.

**B.2.2** Tables 20 to 27 provide reinforcement details for a given span and lintel depth. When designing walls and using these standard designs, care should be taken to ensure that lintels have sufficient depth in relation to the window opening.

**B.2.3** The provision of lintels that have a minimum depth and a maximum clear span in accordance with tables B.1 to B.4 will allow such lintels to be designed in accordance with the standard designs in 4.2.9.

#### **B.3 Rational design of lintels over openings**

**B.3.1** Lintels should be designed as reinforced masonry beams in accordance with the requirements of SANS 10400-B, using SANS 10164-2.

**B.3.2** The load carried by a lintel may be considered to comprise the weight of masonry within a 60° triangle that has a base width equal to 1,1 times the clear span (see figure B.2) and all uniformly distributed and point loads applied within this triangle. Point and uniformly distributed loads may be dispersed from their level of application at 45° to the base of the lintel (see figure B.3).

**B.3.3** Where the masonry is continuous over the lintel, the height should be as in B.3.4 and the width shall be as in B.3.5.

**B.3.4** The height of masonry above the lintel at midspan should be not less than the greater of 0,6 times the clear span and 600 mm.

**B.3.5** The width of masonry on either side of a single opening, or the length of masonry between the external corner of the wall and the side of the opening in multiple openings should be not less than the greater of 600 mm and 0,2 times the longest clear span.

**B.3.6** In accordance with the requirements of B.3.4 and B.3.5, the load carried by the lintel (see figure B.2) may be considered to be

a) the weight of masonry within the load triangle,

## SANS 10400-K:2011

Edition 3

b) a uniformly distributed load at the application level derived by dispersing all applied loads within the load triangle at 45°,

c) a uniformly distributed load at the application level derived by dispersing 50 % of all applied loads within the interaction zone at 45°.

**B.3.7** The span in all cases should be considered to be 1,1 times the clear span.

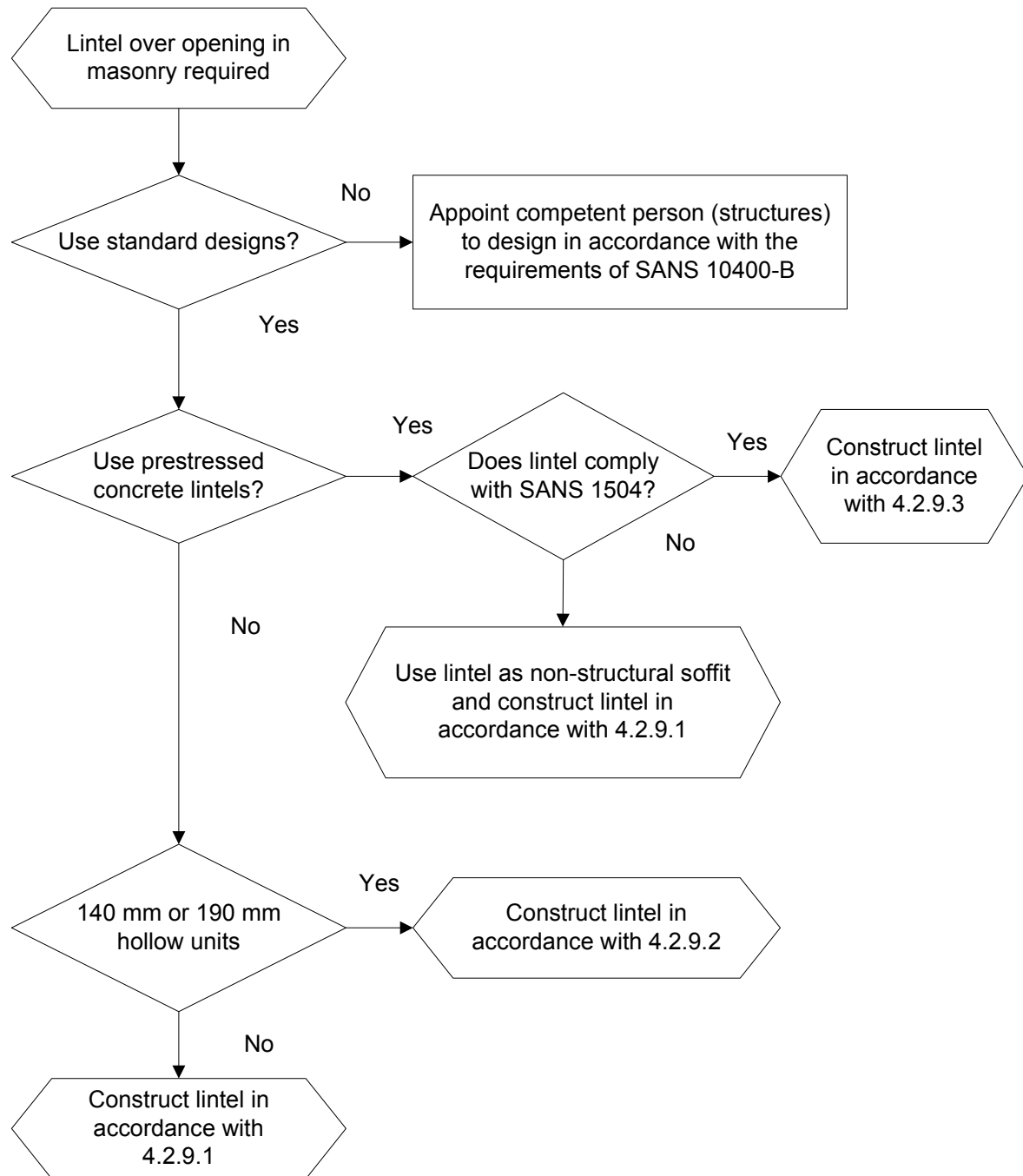

**Figure B.1 — Design of lintels in accordance with the requirements of this part of SANS 10400**



**Table B.1 — Minimum depths of bed joint reinforced lintels required over openings of various spans up to 3,5 m**

1	2	3	4	5	6	7	8	9	10
Minimum depth above soffit course mm			Maximum lintel span m						
Course height mm			No roof	Light roof span m			Heavy roof span m		
85	100	200		4	6	8	4	6	8
<b>90 mm single-leaf wall</b>									
–	400	–	2,5	2,0	2,0	a	1,5	1,5	a
425	–	–	3,0	2,0	2,0	a	2,0	1,5	a
510	500	600	3,0	2,5	2,5	a	2,5	2,0	a
595	600	–	3,0	3,0	3,0	a	2,5	2,0	a
680	700	800	3,0	3,0	3,0	a	2,5	2,5	a
765	800	–	3,0	3,0	3,0	a	2,5	2,5	a
850	–	–	3,0	3,0	3,0	a	3,0	2,5	a
–	900	1 000	3,0	3,0	3,0	a	2,5	2,5	a
935	–	–	3,0	3,0	3,0	a	3,0	3,0	a
<b>110 mm single-leaf wall</b>									
425	–	–	3,0	2,0	2,0	a	2,0	1,5	a
510	–	–	3,0	2,5	2,5	a	2,5	2,0	a
595	–	–	3,0	3,0	3,0	a	2,5	2,5	a
680	–	–	3,0	3,0	3,0	a	2,5	2,5	a
765	–	–	3,0	3,0	3,0	a	3,0	2,5	a
850	–	–	3,0	3,0	3,0	a	3,0	3,0	a
<b>140 mm single-leaf wall</b>									
–	400	–	2,5	2,5	2,5	a	2,0	1,5	1,5
425	–	–	3,0	2,5	2,5	a	2,0	2,0	1,5
510	500	600	3,0	3,0	3,0	a	2,5	2,5	2,0
595	600	–	3,0	3,0	3,0	a	3,0	3,0	2,5
680	700	800	3,0	3,0	3,0	a	3,0	3,0	2,5
<b>190 mm collar-jointed wall</b>									
–	400	–	2,5	2,5	2,5	2,0	2,5	2,0	2,0
475	–	–	3,0	2,5	2,5	2,5	2,5	2,5	2,0
510	500	600	3,5	3,0	3,0	3,0	3,0	2,5	2,5
595	600	–	3,5	3,5	3,5	3,0	3,0	3,0	3,0
680	700	800	3,5	3,5	3,5	3,5	3,5	3,5	3,0
765	800	–	3,5	3,5	3,5	3,5	3,5	3,5	3,0
850	–	–	3,5	3,5	3,5	3,5	3,5	3,5	3,5
–	900	1 000	3,5	3,5	3,5	3,5	3,5	3,5	3,5
<b>220 mm collar-jointed wall</b>									
425	–	–	3,0	2,5	2,5	2,5	2,5	2,5	2,0
510	–	–	3,5	3,0	3,0	3,0	3,0	3,0	2,5
595	–	–	3,5	3,5	3,5	3,5	2,5	3,0	3,0
680	–	–	3,5	3,5	3,5	3,5	3,5	3,5	3,0
765	–	–	3,5	3,5	3,5	3,5	3,5	3,5	3,0
850	–	–	3,5	3,5	3,5	3,5	3,5	3,5	3,5

<sup>a</sup> Not permitted.

**SANS 10400-K:2011**

Edition 3

**Table B.1 (concluded)**

1	2	3	4	5	6	7	8	9	10		
<b>Minimum depth above soffit course</b> mm			<b>Maximum lintel span</b> m								
<b>Course height</b> mm			<b>No roof</b>	<b>Light roof span</b> m			<b>Heavy roof span</b> m				
<b>85</b>	<b>100</b>	<b>200</b>		<b>4</b>	<b>6</b>	<b>8</b>	<b>4</b>	<b>6</b>	<b>8</b>		
<b>90 mm-90 mm cavity wall (solidly filled)</b>											
–	400	–	2,5	2,5	2,5	2,5	2,5	2,0	2,0		
425	–	–	3,0	3,0	3,0	3,0	2,5	2,0	2,0		
510	500	600	3,0	3,0	3,0	3,0	3,0	2,5	2,5		
595	600	–	3,0	3,0	3,0	3,0	2,5	3,0	2,5		
680	700	800	3,0	3,0	3,0	3,0	3,5	2,5	3,0		
<b>110 mm-110 mm cavity wall (solidly filled)</b>											
425	–	–	3,0	3,0	3,0	2,5	2,5	2,5	2,0		
510	–	–	3,0	3,0	3,0	3,0	3,0	2,5	2,5		
595	–	–	3,0	3,0	3,0	3,0	3,0	3,0	2,5		
680	–	–	3,0	3,0	3,0	3,0	3,0	3,0	3,0		
<sup>a</sup> Not permitted.											

**Table B.2 — Maximum span of opening in respect of nominally reinforced shallow bed joint reinforced lintels**

1	2	3	4	5	6	7	8	9	10
<b>Minimum number of courses above soffit course</b>			<b>Primary reinforcement (number × diameter)</b>	<b>Maximum lintel span</b> m					
<b>Course height</b> mm				<b>Light roof span</b> m			<b>Heavy roof span</b> m		
<b>85</b>	<b>100</b>	<b>200</b>		<b>4</b>	<b>6</b>	<b>8</b>	<b>4</b>	<b>6</b>	<b>8</b>
<b>90 mm single-leaf wall</b>									
–	3	–	2 × 5,6	2,0	1,5	2,0	1,5	<sup>a</sup>	<sup>a</sup>
4	–	–	2 × 5,6	2,0	2,0	2,0	1,5	<sup>a</sup>	<sup>a</sup>
5	4	2	2 × 5,6	2,5	2,5	2,5	2,0	<sup>a</sup>	<sup>a</sup>
<b>110 mm single-leaf wall</b>									
4	–	–	2 × 5,6	2,0	2,0	2,0	1,5	<sup>a</sup>	<sup>a</sup>
5	–	–	2 × 5,6	2,5	2,5	2,5	2,0	<sup>a</sup>	<sup>a</sup>
<b>140 mm single-leaf wall</b>									
–	3	–	2 × 5,6	2,5	2,0	2,5	1,5	2,0	1,5
4	–	–	2 × 5,6	2,5	2,0	2,5	2,0	2,0	1,5
5	4	2	2 × 5,6	3,0	2,5	2,5	2,0	2,5	2,0
<b>190 mm collar-jointed wall</b>									
–	3	–	2 × 5,6	2,5	2,0	2,0	1,5	2,0	1,5
4	–	–	2 × 5,6	2,5	2,0	2,5	2,0	2,0	1,5
5	4	2	2 × 5,6	3,0	2,5	2,5	2,0	2,5	2,0
<sup>a</sup> Not permitted.									

**Table B.2 (concluded)**

1	2	3	4	5	6	7	8	9	10
<b>Minimum number of courses above soffit course</b>			<b>Primary reinforcement (number × diameter)</b>	<b>Maximum lintel span</b>					
<b>Course height</b> mm				<b>Light roof span</b> m			<b>Light roof span</b> m		
<b>85</b>	<b>100</b>	<b>200</b>		<b>4</b>	<b>6</b>	<b>8</b>	<b>4</b>	<b>6</b>	<b>8</b>
<b>220 mm collar-jointed</b>									
4	–	–	2 × 5,6	2,5	2,0	2,5	2,0	2,0	1,5
5	–	–	2 × 5,6	2,5	2,5	2,5	2,0	2,0	2,0
<b>90 mm-90 mm cavity wall (solidly filled)</b>									
–	3	–	2 × 5,6	2,5	2,0	2,0	1,5	2,0	1,5
4	–	–	2 × 5,6	2,5	2,0	2,5	2,0	2,0	1,5
5	4	2	2 × 5,6	2,5	2,0	2,5	2,0	2,0	1,5
<b>110 mm-110 mm cavity wall (solidly filled)</b>									
4	–	–	2 × 5,6	2,5	2,0	2,0	1,5	2,0	1,5
5	–	–	2 × 5,6	2,5	2,0	2,0	2,0	2,0	1,5

<sup>a</sup> Not permitted.

**Table B.3 — Minimum depths of bond block lintels**

1	2	3	4	5	6	7
<b>Type of lintel</b>	<b>Minimum overall lintel depth</b> mm	<b>Maximum lintel span</b> m				
		<b>No roof</b>	<b>Light roof span</b> m		<b>Heavy roof span</b> m	
			<b>6</b>	<b>8</b>	<b>6</b>	<b>8</b>
140 mm single-leaf wall	400 600	3,0 3,0	2,5 3,0	1,5 3,0	2,0 3,0	1,5 3,0
140 mm-140 mm bond beam in cavity wall construction	400 600 800	3,0 3,0 3,0	1,5 2,5 3,0	1,5 2,5 3,0	1,5 2,5 3,0	1,0 2,0 3,0
190 mm single-leaf wall	400 600 800	3,0 3,5 3,5	2,0 3,5 3,5	2,0 3,0 3,5	2,0 3,5 3,5	1,5 3,0 3,5

**Table B.4 — Prestressed concrete lintels**

1	2	3	4	5	6
<b>Nominal width</b> mm	<b>Minimum overall lintel depth</b> mm		<b>Maximum lintel span</b> m		
	<b>Course height</b> mm		<b>No roof</b>	<b>Light roof</b>	<b>Heavy roof</b>
	<b>85</b>	<b>100</b>			
≤ 140	425 510 765	400 500 800	3,0 3,0 3,0	2,5 3,0 3,0	2,0 2,5 3,0
≥ 190	425 510 765	400 500 800	3,5 3,5 3,5	2,5 3,5 3,5	2,5 3,0 3,5

**SANS 10400-K:2011**  
Edition 3

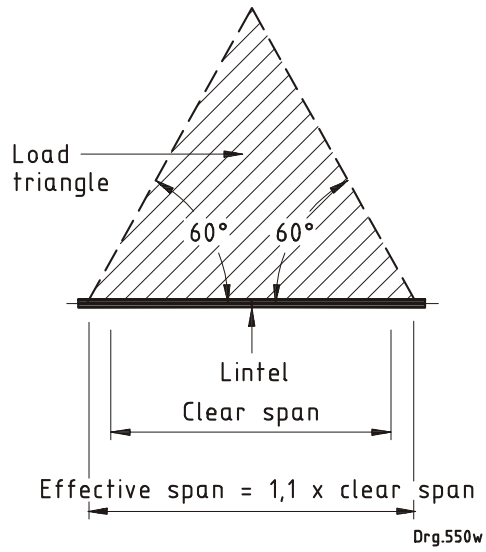

**Figure B.2 — Load triangle**

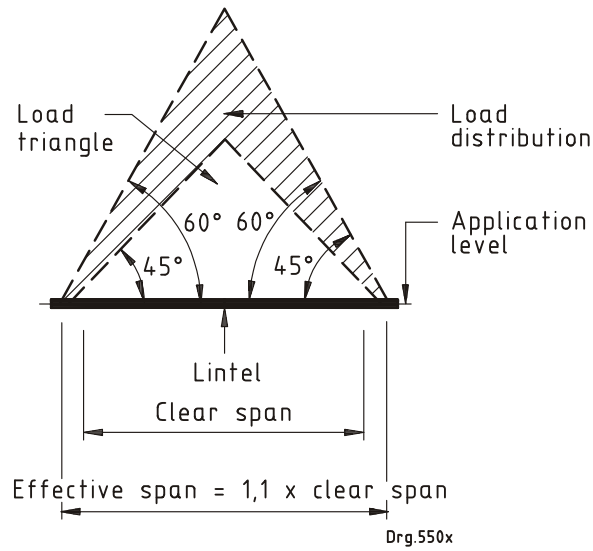

**Figure B.3 — Conditioned interaction zone**

**Annex C**  
(normative)

**Rain penetration tests for walls**

**C.1 Standard non-pressurized test for masonry walls, cast-in-situ concrete or other types of construction without joints**

**C.1.1** Thoroughly air-dry the wall before testing it. In the case of a masonry or similar wall, lime wash the inner surface, or adopt other means to facilitate the detection of moisture which has penetrated through the wall. Spray the portion of the outer surface under test continuously with water in the form of a fine mist distributed over the whole area under test at a rate of 40 mm to 50 mm depth of water per hour. Conduct the spraying in a still atmosphere and continue for the period established in table C.1.

**C.1.2** In the case of a timber-framed wall or walls of similar construction, remove the covering of such wall after the required test period in order to ascertain whether any moisture has penetrated to the interior of such wall and if so, whether water has been retained within the interior.

NOTE The test methods and criteria are derived from conditions where wall surfaces become wet for prolonged periods under normal steady rain conditions. This continuous wetting has a detrimental effect on the ability of a wall to resist rain penetration. Sufficiently large roof overhangs can prevent rain from impinging on wall surfaces under normal steady rainfall conditions. This means that walls would only get wet under severe storm conditions where the rain is accompanied by strong wind. In South Africa such weather conditions are nearly always of short duration. Garden sprinklers can, however, have a detrimental effect on the ability of a wall to resist rain penetration.

**C.2 Standard pressure test for non-standardized walling systems or systems with joints**

**C.2.1** Apply the standard pressure test to a wall tested in terms of C.1. Use the same apparatus, but maintain a constant pressure difference between the inside and outside of the chamber.

**C.2.2** Apply the standard pressure test immediately after the test described in C.1 for an initial period of 15 min with a constant pressure difference of 100 Pa, and thereafter, for a 10 min period, at 200 Pa.

NOTE In addition to non-pressurized tests, pressure tests are carried out to take into account the effect of wind-driven rain if the walling system has unfilled joints or if the construction method is in any way non-standardized (for example, concrete panels, dry-stack, framework with a cladding system, etc.). Wind-driven rain is simulated by subjecting the test wall to a pressure test.

**Table C.1 —Spraying requirements in rain penetration test for walls**

1	2
Description of walls	Spraying requirements
Walls in category 1 buildings protected by a roof overhang in accordance with figure C.1	A period of 2 h in respect of non-masonry walling and no test required in respect of masonry walls with vertical and horizontal joints filled with mortar
Walls in category 1 buildings not protected by a roof overhang in accordance with figure C.1	A period of 4 h
Walls in a building other than a category 1 building	The minimum period required in terms of table C.2 or until the first signs of dampness appear on the inner surface of the wall, if such signs appear before the expiry of such period

**SANS 10400-K:2011**

Edition 3

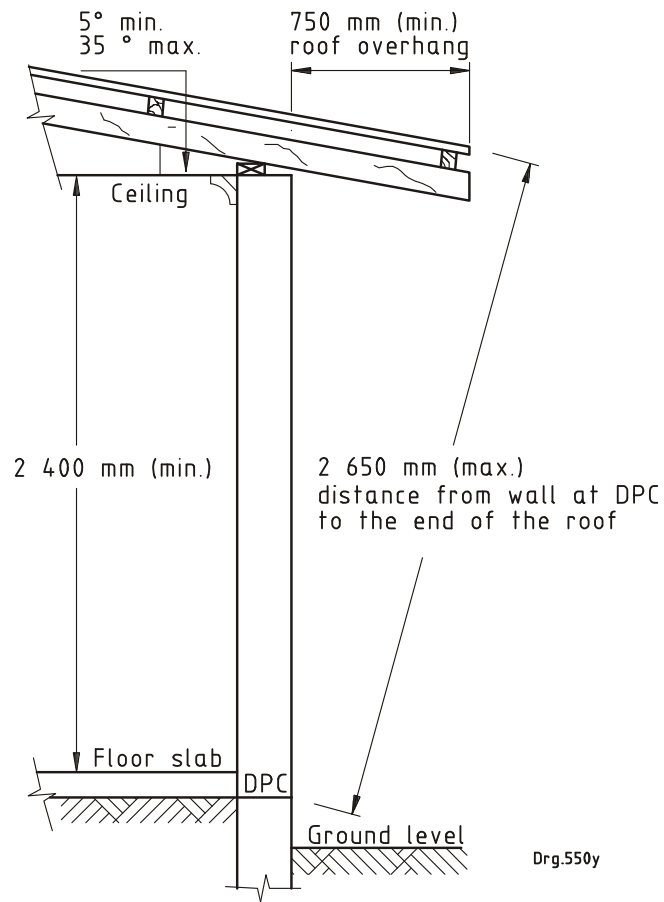

The roof slope shall be between 5° and 35°.

The horizontal overhang from the outside face of the wall to the end of the roofing material shall be not less than 750 mm.

The straight-line distance between the end of the roofing material to the edge of the damp-proof course shall not exceed 2 650 mm.

**Figure C.1 — Roof overhangs which protect walls from rain**

**Table C.2 — Test periods for standard non-pressurized rain penetration tests**

Mean annual rainfall (see figure C.2) mm	Hourly mean wind speed (see figure C.3) m/s	Minimum period h
> 1 000	20	14
	25	19
	30	20
600 to 1 000	20	10
	25	15
	30	20
200 to 600	20	6
	25	11
	30	16
0 to 200	20	2
	25	7
	30	12

NOTE The test should ideally be conducted for the minimum period shown above as this will allow an assessment to be made of the resistance of the walls to water penetration in all rainfall zones in the country.

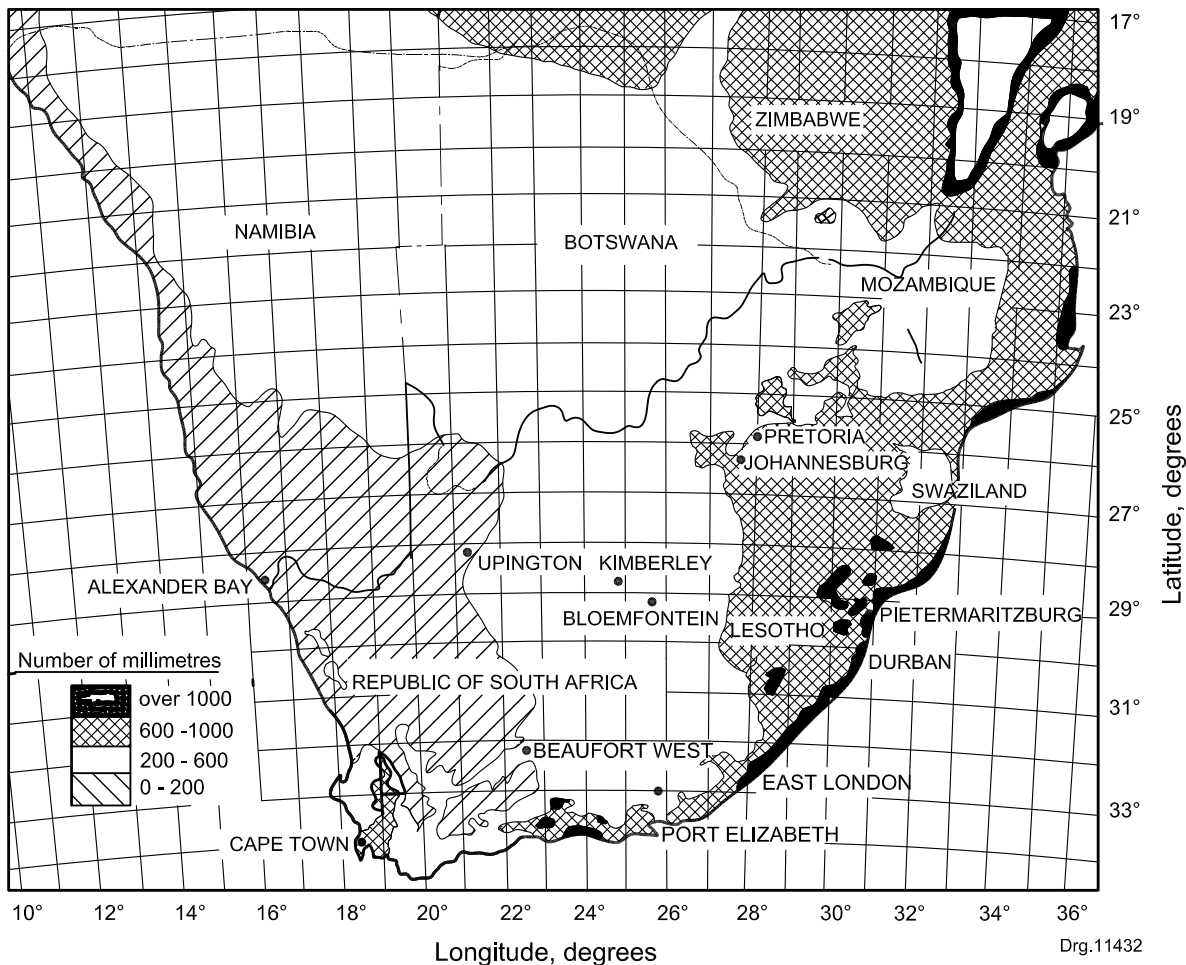

**Figure C.2 — Mean annual rainfall**

**SANS 10400-K:2011**  
Edition 3

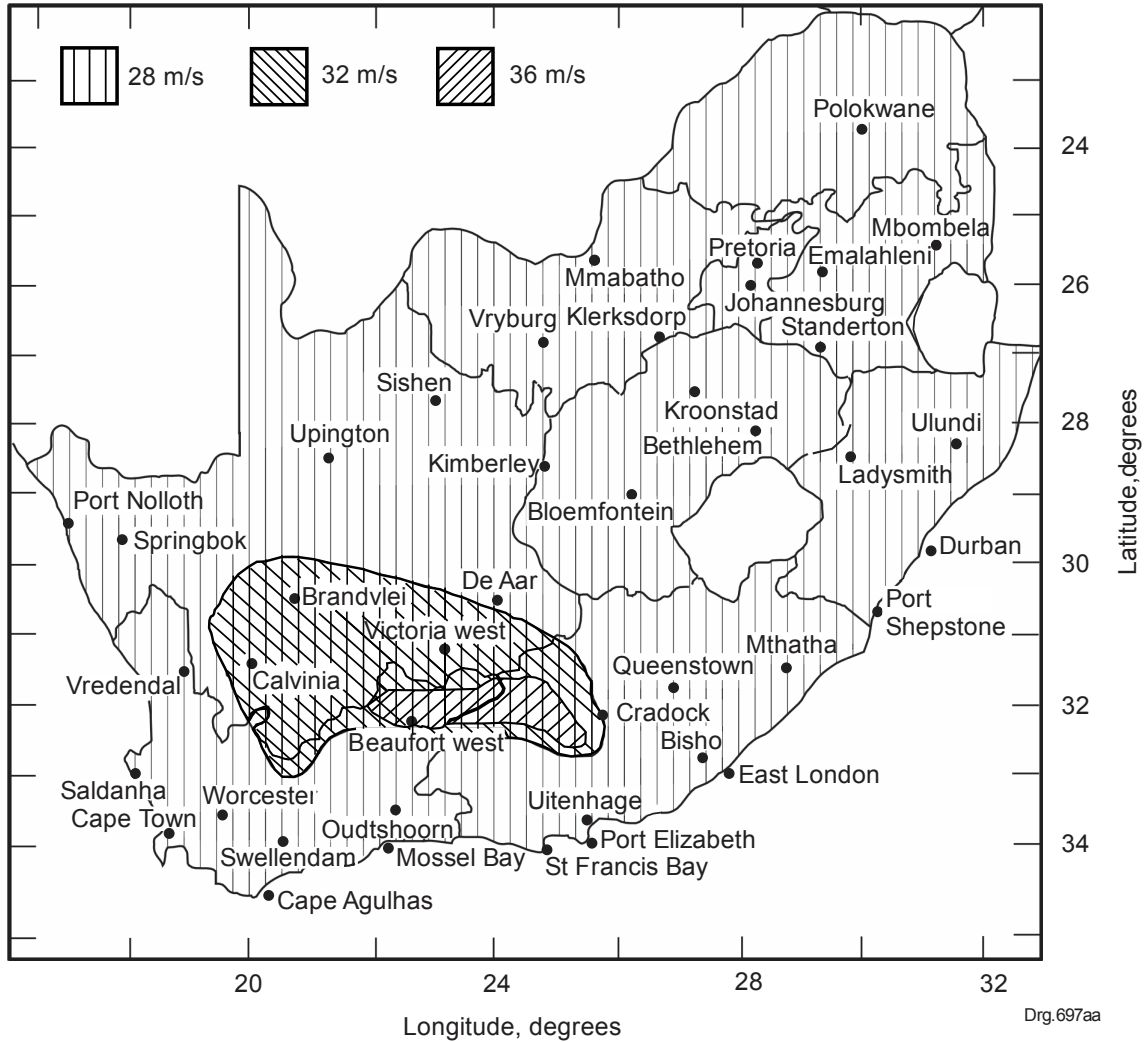

**Figure C.3 — Mean hour wind speeds (m/s)**



## **Bibliography**

### **Standards**

SANS 227, *Burnt clay masonry units*.

SANS 10021, *The waterproofing of buildings (including damp-proofing and vapour barrier installation)*.

SANS 10164-2, *The structural use of masonry – Part 2: Structural design and requirements for reinforced and prestressed masonry*.

SANS 10249, *Masonry walling*.

### **Other publications**

Joint Structural Division of the South African Institution of Civil Engineering and the Institution of Structural Engineers. *Code of practice for foundations and superstructures for single-storey residential buildings of masonry construction*. 1995.

Joint Structural Division of the South African Institution of Civil Engineering and the Institution of Structural Engineers. *Code of practice for the assessment of the performance of housing units in South Africa*. 2000.

Lane JW, Watermeyer RB, De Villiers PD. *Masonry materials and design for movement*. SAICE lecture course, Structural Division, Johannesburg, 1991.

Watermeyer RB. *Free-standing walls – a design guide*. Concrete Masonry Association, 1993.

This page has been left blank intentionally

## **SABS – Standards Division**

The objective of the SABS Standards Division is to develop, promote and maintain South African National Standards. This objective is incorporated in the Standards Act, 2008 (Act No. 8 of 2008).

### **Amendments and Revisions**

South African National Standards are updated by amendment or revision. Users of South African National Standards should ensure that they possess the latest amendments or editions.

The SABS continuously strives to improve the quality of its products and services and would therefore be grateful if anyone finding an inaccuracy or ambiguity while using this standard would inform the secretary of the technical committee responsible, the identity of which can be found in the foreword.

Tel: +27 (0) 12 428 6666 Fax: +27 (0) 12 428 6928

The SABS offers an individual notification service, which ensures that subscribers automatically receive notification regarding amendments and revisions to South African National Standards.

Tel: +27 (0) 12 428 6883 Fax: +27 (0) 12 428 6928 E-mail: [sales@sabs.co.za](mailto:sales@sabs.co.za)

### **Buying Standards**

Contact the Sales Office for South African and international standards, which are available in both electronic and hardcopy format.

Tel: +27 (0) 12 428 6883 Fax: +27 (0) 12 428 6928 E-mail: [sales@sabs.co.za](mailto:sales@sabs.co.za)

South African National Standards are also available online from the SABS website <http://www.sabs.co.za>

### **Information on Standards**

The Standards Information Centre provides a wide range of standards-related information on both national and international standards, and is the official WTO/TBT enquiry point for South Africa. The Centre also offers an individual updating service called INFOPLUS, which ensures that subscribers automatically receive notification regarding amendments to, and revisions of, international standards.

Tel: +27 (0) 12 428 6666 Fax: +27 (0) 12 428 6928 E-mail: [info@sabs.co.za](mailto:info@sabs.co.za)

### **Copyright**

The copyright in a South African National Standard or any other publication published by the SABS Standards Division vests in the SABS. Unless exemption has been granted, no extract may be reproduced, stored in a retrieval system or transmitted in any form or by any means without prior written permission from the SABS Standards Division. This does not preclude the free use, in the course of implementing the standard, of necessary details such as symbols, and size, type or grade designations. If these details are to be used for any purpose other than implementation, prior written permission must be obtained.

Details and advice can be obtained from the Senior Manager.

Tel: +27 (0) 12 428 6666 Fax: +27 (0) 12 428 6928 E-mail: [info@sabs.co.za](mailto:info@sabs.co.za)