

Aircraft Power Plants

by Arthur P. Fraas, M.S.

Test Engineer
Aircraft Engine Division
Packard Motor Car Company

FIRST EDITION
FIFTH IMPRESSION

McGRAW-HILL BOOK COMPANY, INC.

NEW YORK AND LONDON

1943

AIRCRAFT POWER PLANTS

COPYRIGHT, 1943, BY THE
MCGRAW-HILL BOOK COMPANY, INC.

PRINTED IN THE UNITED STATES OF AMERICA

*All rights reserved. This book, or
parts thereof, may not be reproduced
in any form without permission of
the publishers.*

PREFACE

The greatly increased complexity of the engineering problems involved in aircraft-engine testing, installation, operation, and maintenance, coupled with the rapid growth of the aircraft industry, has created a widespread need for an aircraft-power-plant book for engineers. This book is intended to meet that need.

The method of presentation and the material included have been based on experience gained in teaching courses in this subject to classes of U.S. Army and Navy officers, senior and graduate students in aeronautical engineering, and engineers actively engaged in the industry. The aim of the book is to present fundamental terms and concepts that will give the reader a good background of information on all phases of the subject. In most cases, there are a considerable number of books or technical papers in the literature that treat particular items much more thoroughly. Those which have seemed most directly useful to the student have been listed in the references at the end of each chapter.

Since the book is designed primarily to fit the needs of engineering college seniors and of graduate engineers in the armed services or the aircraft industry, it is assumed that the reader is familiar with college physics, thermodynamics, and fluid mechanics. Every effort has been made to make the treatment as simple as the subject permits. Wherever possible, test results have been included to substantiate important points. Widely used empirical rules and formulas have been included where they have seemed appropriate.

The author is grateful to many individuals and organizations for permission to make use of a large part of the illustrations, and especially to the men who have criticized the manuscript.

Professor F. K. Teichmann and R. W. McLane have given outstanding assistance, while W. J. Cake, W. J. Kinderman, H. F. Kueck, G. Z. Ladd, W. E. McClure, W. R. Neely, B. X. Saia, F. W. Thompson, J. C. Vaiden, F. R. Weymouth, and J. T. Wills have been most helpful. The author is grateful to friends who aided in reading proof and is particularly indebted to his wife, who typed and corrected the manuscript.

ARTHUR P. FRAAS.

NEW YORK,
May, 1943.

CONTENTS

	PAGE
PREFACE	v

PART I

Engine Operation

CHAPTER		
	I. HISTORY AND DEVELOPMENT OF AIRCRAFT ENGINES	3
	II. CURRENT ENGINES AND THEIR CONSTRUCTION	18
	III. BASIC OPERATING PRINCIPLES AND DEFINITIONS.	45
	IV. COMBUSTION	57
	✓ V. SUPERCHARGING.	71
	VI. PERFORMANCE	85
	✓ VII. CARBURETION.	115
	VIII. IGNITION.	139
	✓ IX. COOLING.	156
	X. VIBRATION	172
	✓ XI. FUELS AND LUBRICANTS	195
	✓ XII. LUBRICATION, OIL FLOW, AND SCAVENGING	225
	XIII. AIRCRAFT-ENGINE OVERHAUL AND PART DURABILITY.	243
	XIV. LABORATORY TESTING	259

PART II

Engine Installation

	XV. GENERAL INSTALLATION CONSIDERATIONS	283
	XVI. ENGINE MOUNTS	298
	XVII. COWLING OF AIR-COOLED ENGINES.	307
	XVIII. LIQUID-COOLANT SYSTEMS.	327
	XIX. INDUCTION SYSTEMS.	338
	XX. EXHAUST SYSTEMS.	360
	XXI. FUEL SYSTEMS	371
	XXII. OIL SYSTEMS	386
	XXIII. ACCESSORIES AND SPECIAL EQUIPMENT.	398
	XXIV. INSTALLATION TESTING.	408

PART III
Propellers

CHAPTER	PAGE
XXV. PROPELLER THEORY AND PERFORMANCE	421
XXVI. PROPELLER CONSTRUCTION AND INSTALLATION	436

Appendix

I. TABLES AND CURVE SHEETS FOR INSTALLATION DESIGN AND TESTING.	451
II. LABORATORY INSTRUCTIONS.	457
INDEX.	463

PART I

Engine Operation

CHAPTER I

HISTORY AND DEVELOPMENT OF AIRCRAFT ENGINES

Aircraft engines present one of the most interesting groups of problems in the engineering field. The great premiums to be gained from increased power and decreased weight, together with the extreme penalties attached to any malfunctioning of the engine, have led to a refinement of design greater than in any other type of prime mover. The history of the aircraft engine has been more than a record of the evolution of a certain machine: engines developed in any particular period have represented the finest craftsmanship and shop technique available, the best materials, and the most advanced engineering developments in every phase of engine construction and operation. Let us discuss some of the requirements that must be met by a satisfactory engine and investigate the types of engines that have been developed in attempts to meet these requirements.

REQUIREMENTS OF AN AIRCRAFT ENGINE

Weight.—One of the most exacting basic requirements is that the engine weight be kept as low as possible. Since the power loading of military airplanes may be as low as 5 lb per hp, *i.e.*, since the gross airplane weight is only five times the horsepower of its engine, it is immediately evident that the airplane engine must weigh much less than 5 lb per hp to allow for the weight of the airplane structure, pilot, fuel, equipment, and pay load. As a result of years of development, modern aircraft engines weigh between 1.0 and 2.0 lb per hp. It is interesting to note that the 1,000-hp locomotive diesel engines for the “lightweight” streamlined trains weigh about 15 lb per hp.

Power Output.—The maximum requirement for power in aircraft operation occurs during the take-off and the initial climb. The power available for this purpose is called the *take-off power*. It represents the maximum power that the engine can safely supply for short periods of time. A limit of 1 to 5 min is usually

specified. The maximum power that may be used for extended operation is called *rated power*. This is ordinarily about 90 per cent of the take-off value. Since the maximum altitude at which an engine will develop its rated power is very important, this, the *critical altitude*, usually accompanies the rating. In an engine having a two-speed or a two-stage supercharger, two rated powers are ordinarily given, one at each of the two critical altitudes. The power that is used for the level-flight operation is known as *cruising power*. This is usually 70 per cent of rated power or less and is determined by the engine operating conditions that will give the maximum number of ton-miles per pound of fuel carried. Engine specifications often include a guaranteed minimum specific fuel and oil consumption at some horsepower which is typical of that to be expected in service use and so is designated as *cruising power*.

Dependability.—Above all else, those buying, flying, and being transported by aircraft want complete engine reliability. Engine failure over water or bad terrain or in bad weather can cause serious and expensive damage to the airplane and, quite possibly, disaster for the occupants. Forced landings due to engine trouble were common experiences in the decade immediately following the First World War. The first rule of flying then was: *Always have in mind a possible landing field within gliding range.* By carefully investigating all potential sources of trouble and concentrating intensive development on the parts involved, the engines were improved. The air lines were one of the most important factors in this development. The long hauls, which offered the most promising field for air-line work in America, turned out to be the best possible proving ground for aircraft equipment of all kinds, especially engines. By painstaking, meticulous attention to the smallest details, engines in air-line use in this country in recent years have achieved virtually perfect records for dependability. The comparatively short hauls in Europe, on the other hand, resulted in less attention to the matter of engine dependability, especially since government subsidies there encouraged development of military equipment for which considerations other than dependability were paramount.

To ensure dependability, each engine model must pass a rigorous type test of 150 hr before it is accepted by the U.S. Army or Navy or licensed for commercial use. This type test includes

a thorough calibration to determine the engine's capabilities and requirements, and many hours of high-power endurance testing.

A table of the type test requirements for both this country and other major powers is given below. It is based on data available at the beginning of the Second World War.

TABLE I.—TYPE TEST REQUIREMENTS*

	Total hours running	Hours at take-off power	Hours at rated power	Hours at over-speed	Hours at 70-90 per cent rated
United States.....	150	10	50	5	85
England.....	153	9	42	1	101
France.....	113½	3	10	½	100
Germany.....	107	7	100
U.S.S.R.....	100	..	96	...	4

* Nutt, A., *Aircraft Engines and Their Lubrication*, S.A.E. Trans., vol. 34, 1939.

It should be noted that American tests are even more severe than is indicated, for they require that the majority of the operating conditions be at the worst extreme of the guaranteed operating limits, which is not the case in most of the tests run abroad.

Operating Requirements.—The wide variety of operating requirements to be met has presented difficulties unheard of in other fields. Aircraft engines must be able to respond almost instantly to power demands. It must be possible, for example, to increase the engine power output from an idle to the full take-off rating in a fraction of a second. An engine may be called upon to operate at sea-level atmospheric pressure, with air temperatures of over 100°F, and, in the space of a few minutes, may climb to a high altitude where the temperature is 65°F below zero and the air pressure only 20 per cent of that at sea level. The engine must be capable of operation in a wide range of flight attitudes; it must be unaffected by a steep dive, a rapid climb, inverted flight, a vertical bank, or other aerobatics. It must fly through sandstorms and ice storms alike without suffering damage. Other requirements are easy starting and quick warm up, high power in the low-density air at high altitudes, low cost, fuel and oil economy, and simple maintenance. Obviously,

all these requirements cannot be met completely, but they give some notion of what is expected of an aircraft engine.

TYPES OF AIRCRAFT ENGINES

Potential Prime Movers.—While steam engines, gas turbines, and rocket motors have all been suggested and actually tried for aircraft propulsion, the internal-combustion engine which derives its power from a piston reciprocating in a cylinder has been the only aircraft power plant to be widely used. When one considers that this type of engine has demonstrated its low cost, dependability, and relatively light weight in automotive, marine, railroad, and stationary-engine applications, it is not surprising that it has proved to be the most suitable for aircraft use. The basic principles that apply to an aircraft engine apply to an automobile engine, for example, though the latter has had to meet much less stringent and less diversified requirements.

Spark Ignition vs. Diesel.—The relative merits of the diesel and the spark-ignition engine present a problem that never fails to arouse spirited argument among groups of men interested in engines. All sorts of arguments have been used to explain the absence of the diesel from the high-power aircraft-engine field. As a matter of fact, as this is written there is not a single high-performance aircraft diesel in military use anywhere in the world, not even in Germany where so much research work has been done on the problem. This is mainly due to the fact that engine weight is largely a function of the peak pressure developed in the cylinder during combustion. The peak pressure in a diesel cylinder is much greater for a given mean effective pressure (mep) than in a spark-ignition engine. This means that for a four-stroke cycle engine of a given size and power output, the diesel must inevitably be heavier.

Since the diesel requires more air to deliver a given horsepower, the altitude performance of diesels is inherently somewhat inferior to that of spark-ignition engines. Further, the diesel is generally harder to start in cold weather, and it is usually not so flexible, *i.e.*, it does not operate smoothly and accelerate rapidly over so wide a range of powers and speeds as the spark-ignition engine.

Air vs. Liquid Cooling.—One of the most hotly contested questions in the aircraft-engine field has been that of air cooling vs.

liquid cooling. The problem is closely tied up with that of cylinder arrangement, for it is possible to cool a cylinder as well with air as with a liquid if there is room for deep cooling fins on the cylinder heads and barrels. As a matter of fact, air is the ultimate coolant in either case, for the liquid-cooled engine must pass its coolant through an air-cooled radiator. The somewhat greater flexibility possible in the design of both the engine itself and its installation in the airplane have favored the liquid-cooled engine. Its inherently greater weight due to the coolant, radiators, and plumbing has been its chief disadvantage.

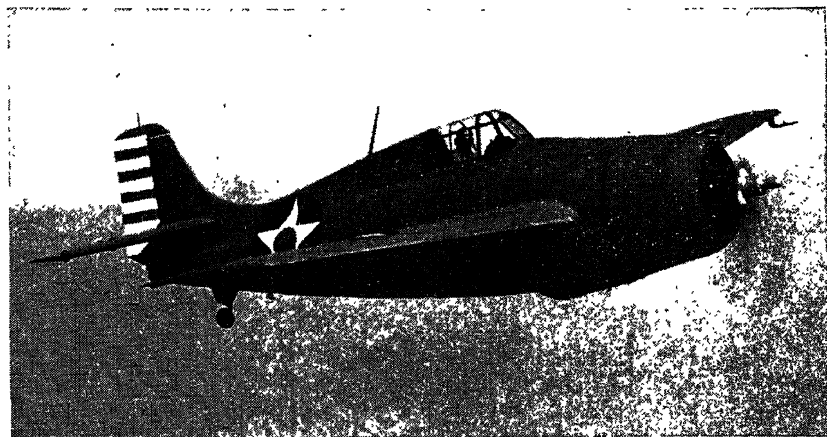

FIG. 1.—Navy Wildcat fighter powered with an air-cooled radial engine. (*Grumman Aircraft Engineering Corp.*)

The liquid-cooled engine has been associated in the minds of most people with pursuit airplanes having fuselages of small cross-sectional area. It should be mentioned that the frontal area of an aircraft engine was not a vitally important factor until the beginning of the Second World War, for until then airplane speeds were well below the velocity of sound. Since the speed of air passing over certain areas of an airplane, particularly the engine cowling, may be two or three times that of the speed of the plane, the point was reached where the engine and its cowling constituted one of the most important factors limiting the top speed of an airplane. So-called "shock waves" are actually set up in the regions in which supersonic air velocities occur. These result in greatly increased drag and a materially lower top speed for the airplane. The frontal area of the engine thus became

very important. For engines in the 1,200-hp class, the 60-deg liquid-cooled V-engine including its radiator has had less than half the frontal area of the air-cooled radial and so has made possible a cleaner, more simple cowling. It happens that this advantage seems to disappear in the 2,000-hp class because large twin-row radial engines are little if any larger in diameter than the 1,200-hp single-row radial engines. Thus the air-cooled engine is not handicapped by its frontal area in the higher power range.

Figure 1 shows a Grumman Wildcat powered with an air-cooled radial engine; Fig. 2 shows a North American Mustang

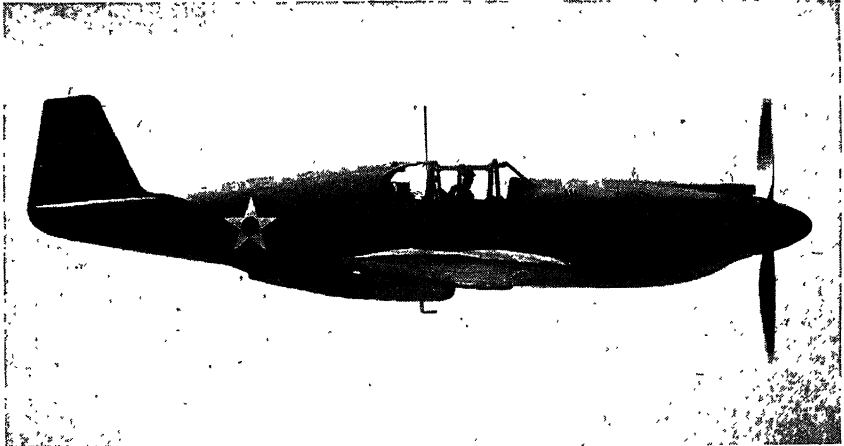

FIG. 2.—North American Mustang fighter powered with a liquid-cooled V-engine.
(North American Aviation, Inc.)

powered with a liquid-cooled engine. These airplanes prove that excellent performance can be obtained from an airplane designed around either an air-cooled or a liquid-cooled engine.

Cylinder Arrangement.—One of the most important characteristics of an engine is the way in which the cylinders are arranged around the crankshaft. If all kinds of internal-combustion engines are considered, by far the most common type is the in-line engine in which the cylinders are arranged one behind the other with their axes parallel. A common crankshaft with one crank “throw” for each cylinder serves to transmit the power. Virtually all automobile and truck engines, heavy-duty stationary and marine engines, and many aircraft engines have been of this type. The in-line engine is readily liquid-cooled, the one-piece

cylinder block generally used for this purpose being especially good from both the production and the maintenance standpoints. By careful baffling, it is possible to get good cooling in an air-cooled in-line engine, although the difficulties become considerable if cylinders more than about 5 in. in diameter are used.

One serious disadvantage of the in-line engine is its long flexible crankshaft, which poses torsional vibration problems extremely difficult to solve. After one has looked at the long springlike crankshaft of a 12-cylinder V-engine and given a little consideration to the amount it would deflect when acted on by the combustion forces in an engine developing 1,000 to 1,500 hp, one can begin to realize why engineers have been reluctant to attempt its use in engines of twice that power output.

In many ways the radial engine offers the most simple cylinder arrangement. By grouping the cylinders radially around the crankshaft like the spokes of a wheel, use is made of every bit of material in the crankcase. The crankshaft and crankcase are short and relatively light; the power input of the combustion forces in the cylinders is quite uniform; and the induction system can be made nearly symmetrical to ensure good distribution of the fuel-air mixture to the cylinders. Although the radial engine does not lend itself to liquid cooling because the cylinders are spread far apart, it offers an ideal arrangement for uniform air cooling. Although they may not appear so to the layman, radial air-cooled engines are more simple in construction and are more easily worked on than liquid-cooled V-engines. Valve trouble in one cylinder, for example, does not require the removal of an entire cylinder block as in an in-line engine: it is necessary to remove only the one cylinder head and barrel assembly. This is even more of an advantage if it is necessary to change or examine a piston or a set of piston rings. In short, the principal advantages of the air-cooled radial are its simplicity, light weight, simple maintenance, and low cost. American air-cooled engines have proved to be decidedly superior in rugged dependability to any other large aircraft engines in the world.

Many other cylinder arrangements have been used in the past. Since the biggest demand has always been for more and more power, one natural tendency has been to "multiply" the power of existing engines by "doubling" them, *i.e.*, by putting two together. The X-engine is a logical multiple of the V-engine,

though it poses the same problems of rod attachment to the crankshaft that the radial engine does, as well as greatly aggravated torsional vibration problems. An arrangement more simply engineered is the coupling of two V-engines placed side by side by a gear train so that they drive a common propeller shaft. The 2,000-hp. Allison V-3420 (3420 cu. in. displacement) is of this type. Unfortunately, such an arrangement is afflicted not only with all the troubles the original single V possessed, but it has new varieties of its own. Its frontal area is more than double that of the single V-engine and, including radiators, is about equal to that of a double-row radial engine of equivalent power.

Another multiplication of the in-line engine is the opposed-cylinder type in which two banks of cylinders are used. One bank is placed on either side of the common crankshaft. The majority of light-plane engines are of this type, while a few larger experimental engines have been built. Such an engine has good possibilities for a submerged engine installation in a wing.

The double-row radial air-cooled engine has become one of the most important of all engine types. Essentially, it consists of two rows of radial cylinders, with one row displaced with respect to the other so that the cylinders in the rear row lie in the gap between the front-row cylinders and thus are easily air-cooled. American aircraft-engine manufacturers have led in the development of this type. Subsequent chapters will often refer to these engines. A logical multiple of the radial engine in answer to the ever-present demand for more and more horsepower is a series of three, four, or more radial engines, one behind the other, so that the cylinders are placed about a long cylindrical crankcase like the kernels of corn on a corncob. Such an engine could be built in units of very high horsepower with low frontal area, especially if liquid-cooled.

The so-called "barrel" engine in which the cylinders are grouped around a central shaft with their axes parallel like the chambers of a revolver is a type which has been proposed many times, and a few such engines have been built. Transmission of power from the pistons to the shaft is usually accomplished by means of *swash*, or *wabble*, *plates*, although cam arrangements have also been developed. Whatever means are used, difficult bearing and other problems arise. One American marine diesel barrel engine has been built in production quantities and has

proved successful, but one look at its complicated and massive rod mechanism is enough to convince even the layman that some other lighter and simpler power-transmission arrangement must be devised if the barrel engine is to be used in aircraft. Several mechanisms that show promise and that, if developed, may make possible the production of a superior aircraft engine of the barrel type have been described in detail by Hall.^{1*}

REPRESENTATIVE ENGINES

Air-cooled Radial Engines.—The Gnome *Monosoupape* was developed in France in 1909 and played an important part in the First World War. The first air-cooled radial engine to be widely used, it was of the rotary type, *i.e.*, the cylinders and crankcase revolved around the stationary crankshaft. This gave good cooling-air circulation but made engine lubrication and airplane vibration difficult problems. The fuel-air charge was induced through the crankcase and thence through valves in the tops of the pistons. A single exhaust valve was used in the center of the cylinder head. An outstanding feature was the use of the articulated-rod system employed in most later radial engines. Rotary engines of this type developed as much as 125 hp at 900 rpm.

The Lawrence J-1 was the first American air-cooled radial engine. The Wright J-5, shown in Fig. 3, was developed directly from this engine and became the first American air-cooled radial engine to be manufactured in large numbers. It powered the airplanes used in many famous flights including that of Charles Lindbergh from New York to Paris and that of Richard Byrd across the North Pole. This was the forerunner of the tens of thousands of air-cooled radial engines that have been built since this engine first went into production. Figure 4 shows a highly developed single-row radial engine, the nine-cylinder Wright Cyclone, which is in production at the time of writing.

Pratt and Whitney developed the first twin-row radial engines to become widely used. The 14-cylinder engine shown in Fig. 5 is typical of the 14- and 18-cylinder twin-row radial engines that have come to play such an important part in larger aircraft. Both Germany and Japan have copied the features developed in American air-cooled radial engines.

* Superior numbers refer to bibliographic references at the end of each chapter.

A unique series of air-cooled radial engines (see Fig. 6) employing sleeve instead of poppet valves has been developed in Great

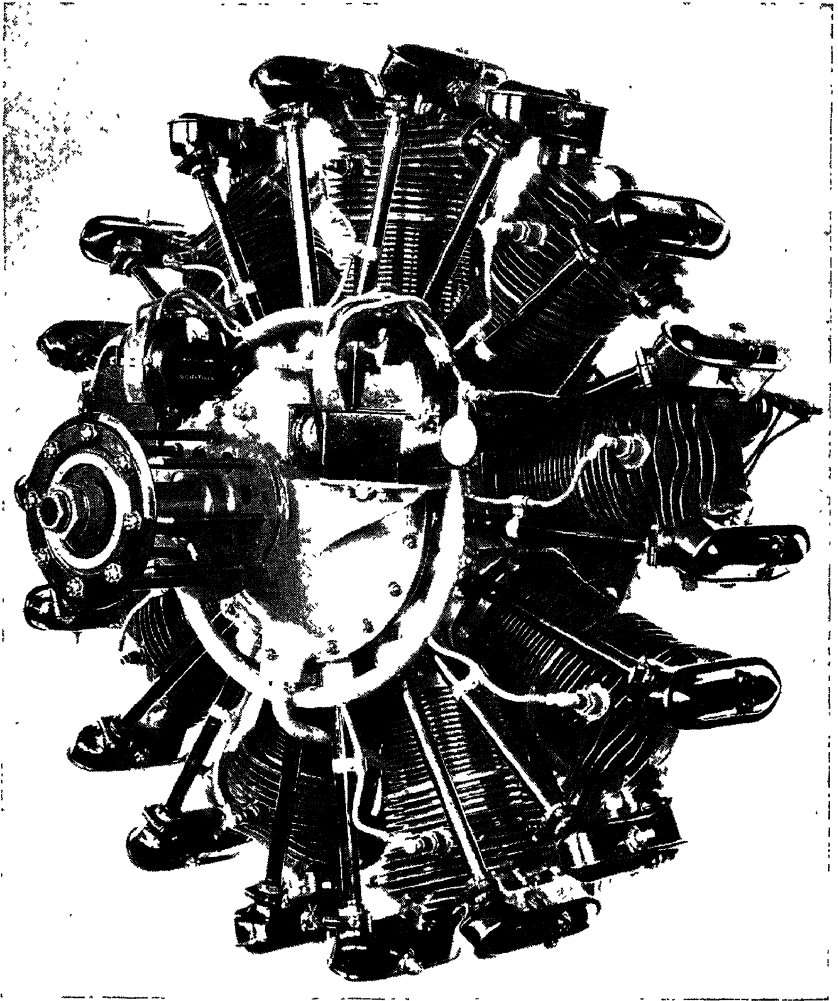

FIG. 3.—Wright J-5 Whirlwind air-cooled radial engine. (*Wright Aeronautical Corp.*)

Britain. The details of the valve mechanism used will be discussed in the next chapter (see page 29).

Air-cooled In-line Engines.—Figure 157 shows a late model of a six-cylinder air-cooled in-line engine. Similar engines have been built in many different countries.

The four-cylinder horizontally opposed air-cooled engine such as that shown in Fig. 7 is an outstanding American development. First built in production in 1930, it has become by far the most popular type of power plant in the light-plane field.

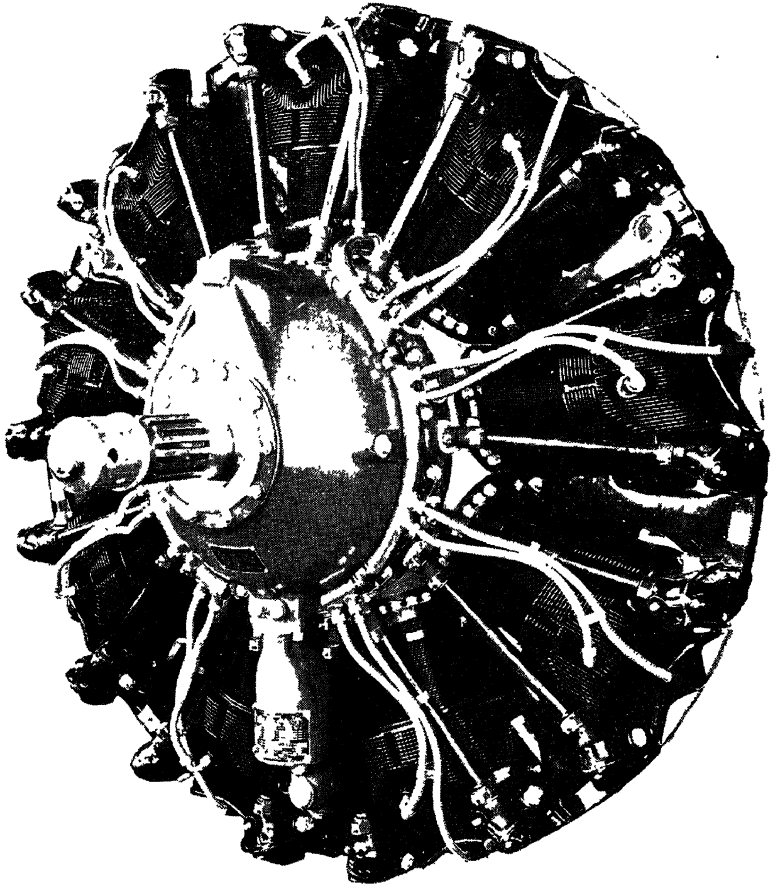

FIG. 4.—Wright C9GC Cyclone nine-cylinder single-row radial engine rated at 1,200 hp for take-off. (*Wright Aeronautical Corp.*)

Liquid-cooled Engines.—The eight-cylinder V Hispano-Suiza engine was used in many airplanes during the First World War. It was the first to incorporate cast-aluminum-alloy cylinder

blocks with steel liners, a feature of construction that has come to be used in all the leading liquid-cooled aircraft engines.

The Allison V-1710-F is shown in Fig. 8. It is similar to the British Rolls-Royce Merlin, while the 12-cylinder German

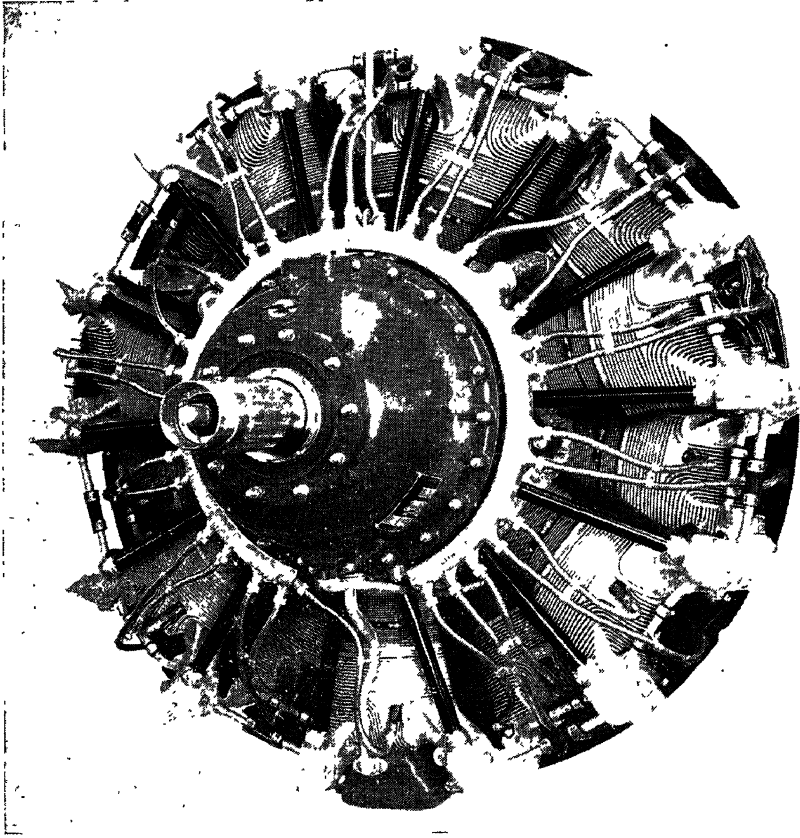

FIG. 5.—Pratt and Whitney Twin-Wasp 14-cylinder twin-row radial engine rated at 1,200 hp for take-off. (*Pratt & Whitney Aircraft.*)

engines differ mainly in that they are inverted so that the crankshaft and propeller shaft are placed at the top.

Diesel Engines.—While the great majority of aircraft engines are of the spark-ignition type, one American and a number of German aircraft engines are diesels. The American Guiberson has been developed in units of about 300 hp. At the time of writing, it is being used principally in tanks, as are many spark-ignition radial aircraft engines.

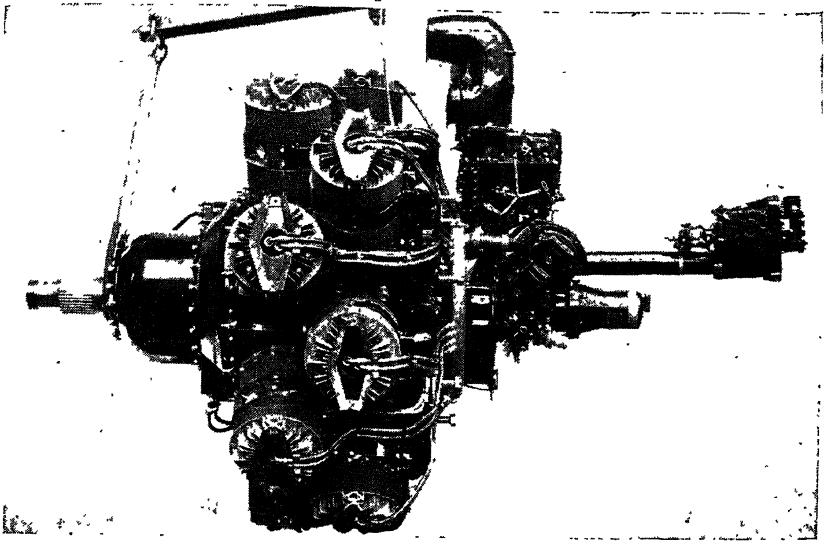

FIG. 6.—Bristol Hercules sleeve-valve air-cooled radial engine with air scoop and accessory-drive gear box. (*The Bristol Aeroplane Co., Ltd.*)

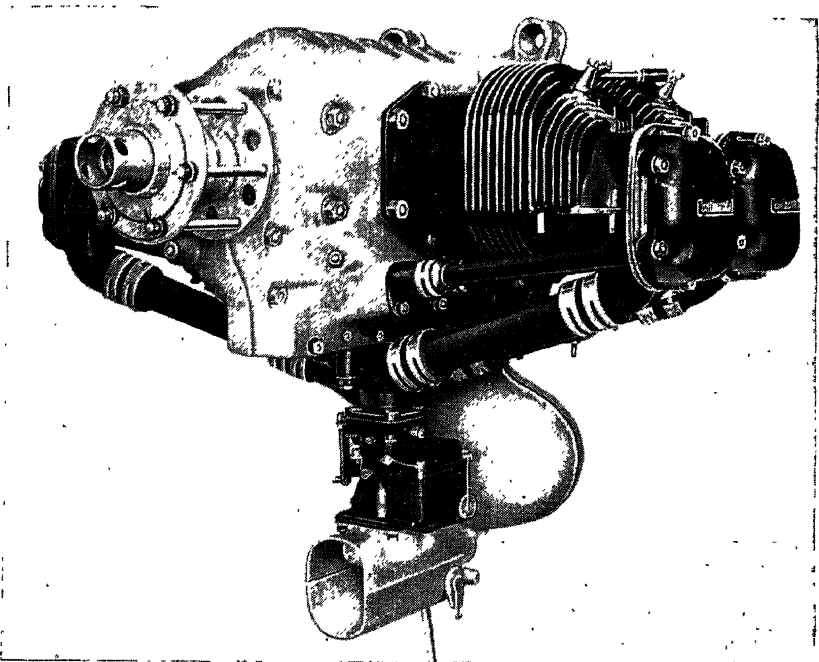

FIG. 7.—Continental four-cylinder opposed-type air-cooled engine. (*Continental Motors Corp.*)

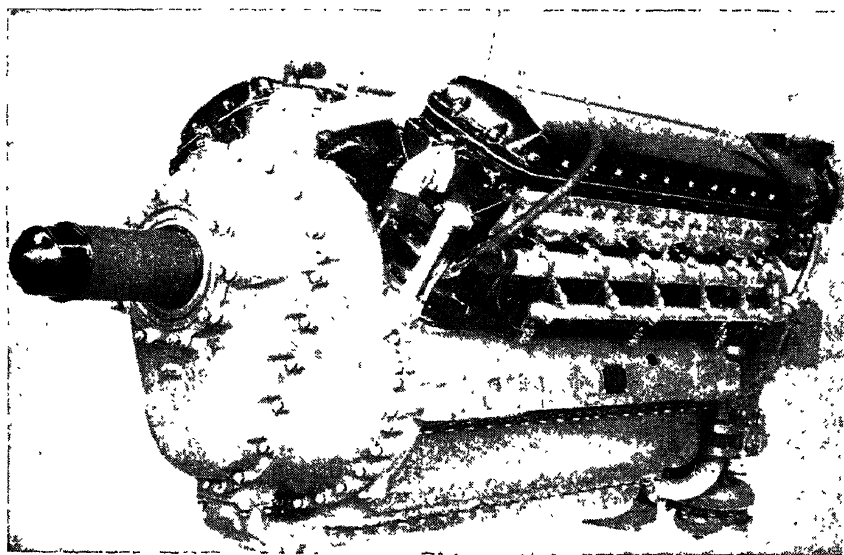

FIG. 8.—Allison V-1710-F 12-cylinder liquid-cooled V-engine. (*Allison Division General Motors Corp.*)

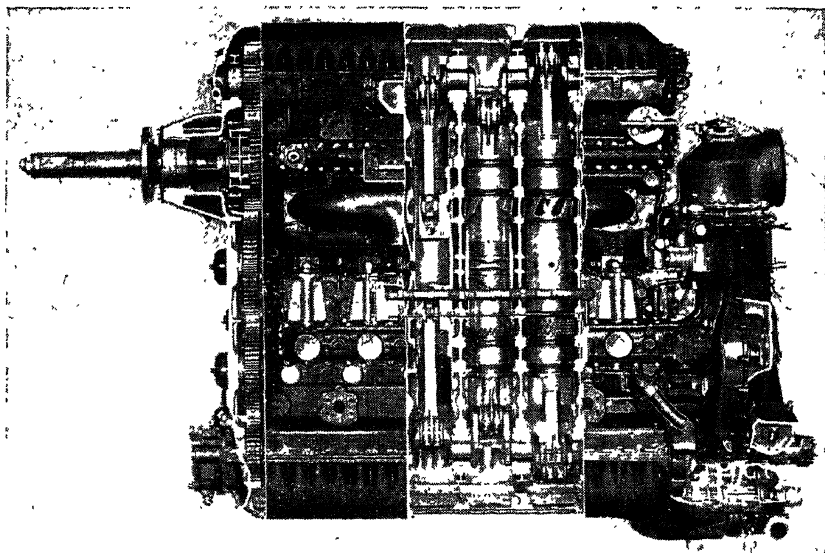

FIG. 9.—German Junkers Jumo 205 opposed-piston two-cycle diesel engine (*Aerosphere.*)

The German Junkers Jumo 205 is shown in Fig. 9. An opposed-piston piston-ported two-cycle engine with two crankshafts, it has been used in training planes and in long-range flying boats.

ENGINEERING PROBLEMS OF THE AIRCRAFT POWER PLANT

Many wonder why numerous new types of engines are not rapidly developed in a war emergency. The answer is that it takes a long time—at the very least two or three years—to develop a good aircraft engine. One cannot treat factors like combustion, piston lubrication, crankshaft vibration, air flow, and part durability as one great equation and obtain an answer with a calculating machine. One may try to, of course, but he will almost certainly be seriously disappointed. The sounder method is to design and build a modification of an existing engine. A program of experimental testing must be launched to disclose the weaknesses of the new design. Part failures and operating troubles may be diagnosed after each test so that the engine parts may be reworked or new parts made for another test. Months of cut-and-try experimental work must follow before the engine is ready for production. When a new engine finally goes into production and units are put into regular service, a whole new set of “bugs” always seems to appear to make still more development work necessary. Thus much engineering work must accompany the design and experimental program for a new model engine.

Not only are the problems of engine design and development complex, but much engineering work must be done if the engine installation in the airplane is to be satisfactory in every respect. The problems connected with installation are particularly involved and require a thorough understanding of the principles of engine operation. Similarly, maintenance of the complex power plant of a modern airplane requires the supervision of highly trained engineers. This book is intended to give the fundamentals of the engineering background required for all types of engineering work on aircraft engines.

References

1. HALL, E. S.: More Power from Less Engine, *S.A.E. Trans.* vol. 35, 1940.
2. NUTT, A.: Aircraft Engines and Their Lubrication, *S.A.E. Trans.*, vol. 34, 1939.

CHAPTER II

CURRENT ENGINES AND THEIR CONSTRUCTION

It was pointed out in the preceding chapter that the four-stroke-cycle spark-ignition internal-combustion engine has been the only prime mover to be widely used in aircraft. American engines in use as this is written fall into an even narrower classification. It has been possible to simplify the material in subsequent chapters considerably by directing the discussion primarily toward these engines. Therefore, unless otherwise noted, statements made in this and the following chapters will be concerned primarily with American engines in large-scale production as this book goes to press.

Four principal types of engines have constituted the great bulk of aircraft power plants. These are as follows:

1. Air-cooled radial engines (Fig. 4).
2. Liquid-cooled V-engines (Fig. 8).
3. Air-cooled in-line engines (Fig. 157).
4. Air-cooled horizontally opposed engines (Fig. 7).

The air-cooled radial engine has been widely used in units of 200 to 2,500 hp, in all types of airplanes. The liquid-cooled V-engine has proved itself to be an excellent power plant for military airplanes of the pursuit type. The in-line air-cooled engine has shown excellent characteristics for use in airplanes requiring power plants of 150 to 600 hp. The horizontally opposed cylinder air-cooled engine has been by far the most widely used type in the so-called light airplanes that use engines of 50 to 200 hp.

In the aircraft field, in which there are so many important considerations and conflicting requirements, one is not surprised to find considerable specialization of design so that an airplane of maximum performance is available for each type of work. The long-range heavy bomber is quite unlike the light attack bomber, for example. Such specialization has not extended to the engine

—the power plant installed in an interceptor fighter may be used in a heavy bomber. Part of the reason for this is that any particular engine model requires an immense amount of test and development work. The time and expense needed for this work are not justifiable unless the engine is adaptable for use in many different types of aircraft. As a matter of fact, so few reliable aircraft power plants have been available that the customary procedure has been for the airplane manufacturer to design each airplane around a particular engine with which he is familiar or one which he has definite assurance will be available for installation before the airplane itself is finished.

Not only has the number of different engines that have been built in large quantities been relatively small, but the features and devices used in the construction of these engines have been surprisingly similar. Thus it is possible to cover in only one chapter the main elements employed in the construction of most American aircraft engines.

A number of the conventions used in describing engine elements should be mentioned. The propeller end of the engine is referred to in service manuals as the *front* end because the great majority of engine-propeller installations are of the tractor type. Similarly, the antipropeller end is referred to as the *rear*. The direction of rotation of the crankshaft is described as it would appear from the rear. The crankshafts and propellers of most American engines rotate clockwise. The cylinders of radial engines are numbered in the direction of rotation, starting with No. 1 cylinder at the top. In twin-row radial engines, No. 1 cylinder is located in the rear row. Thus all the rear cylinders have odd numbers, and the front cylinders have even numbers. The same conventions apply to in-line and opposed-cylinder engines except that the cylinders are numbered starting with No. 1 cylinder at the rear. In V-engines, the cylinders are numbered starting from the rear, and the cylinder banks are designated as *left* or *right*, again as viewed from the rear.

THE AIR-COOLED RADIAL ENGINE

The air-cooled radial engine is the outstanding American type. It is especially suitable as a first example because the basic features of its construction are much the same, regardless of the manufacturer. Further, most of these features are employed

in other types of aircraft engine. Pratt and Whitney Aircraft and the Wright Aeronautical Corporation are the only American manufacturers who have developed the radial engine in units of 1,000 hp or more. Other smaller companies build air-cooled radial engines of as much as 300 or 400 hp that are similar in construction to the larger engines except where simplification has been possible.

Housings.—The various parts of an engine are placed within or attached to a structural shell consisting of a number of *sections*, or *housings*. Figure 10 shows an exploded view of the housings

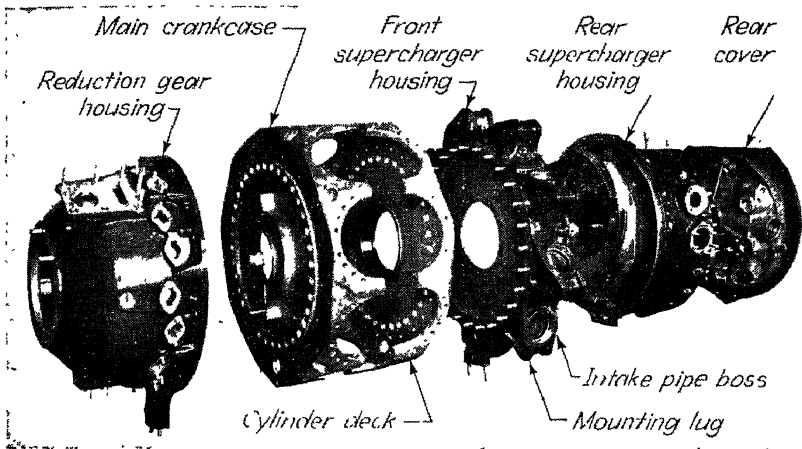

FIG. 10.—Exploded view of the crankcase of a nine-cylinder radial engine. (Wright Aeronautical Corp.)

for a single-row radial engine. That at the left is the *crankcase front-section*, or *reduction-gear housing*. It usually encloses the cam, cam drive gears, tappets, and, in geared engines, the reduction gears. The next two shown are the front and rear halves of the *main crankcase*, or *main case*. The main crankcase houses and supports the *crankshaft*, and to it are attached the *cylinder assemblies*, or *cylinders*. The flat surface against which each *cylinder hold-down flange* bears is called a *cylinder deck*. The main case is usually made up of two main parts in single-row radials and of three main parts in twin-row radials. These parts are separated by a parting surface in the plane of the center lines for each row of cylinders. The *blower*, or *front-supercharger housing* is attached to the rear of the main crankcase. The

lugs protruding from its periphery are the *mounting lugs* with which the engine is attached to its mount in the airplane. The *intake pipes*, through which the fresh charge of fuel and air flows to the cylinders, fit into the *intake-pipe bosses*, which are integral with the mounting lugs. The *rear-supercharger housing* and the *rear cover* enclose the supercharger and accessory drive gears. Most of the accessories and the carburetor are mounted on these two parts.

Housings are usually made of aluminum or magnesium alloy, which makes it desirable to use studs for most attaching purposes. The cylinders, for example, are ordinarily attached to the main case by means of studs in the latter. The reason for this is that threads in aluminum present a problem because of the relatively soft "gummy" character of the material. If a cap screw in a tapped hole in aluminum is heavily loaded, it will tend to seize. When removed, it will be likely to tear away the aluminum and spoil the threads.

Steel main crankcases were tried in Wright Cyclone engines in 1937. These were so satisfactory that all the later models of Wright Cyclone engines have used steel crankcases. In these engines the light-alloy nose section and the cylinders may be attached to the main case by means of cap screws, and thus the handling and other annoyances that accompany studs are greatly reduced.

Connecting Rods and Crankshaft.—The articulated-rod system has proved to be the most satisfactory mechanism yet worked out to connect the seven or nine pistons of the conventional radial engine to the same crankpin (see Fig. 11). The *master rod* is a connecting rod that has been enlarged at the crank end to provide two flanges in which *knuckle-pin holes* have been drilled, one pair of holes for each of the other rods. The small *articulating rods*, also called *link rods*, are attached to the master rod by means of *knuckle pins*. These are made to give a medium press fit in the master rod and a loose fit in the *knuckle-pin bushing* of the link rod. Link rods have bronze bushings in both ends. All Wright engines utilize one-piece master rods, assembly being made possible by "breaking" the crankshaft at one end of the crankpin. A heavy clamp joint is used for this purpose to give a simple, rugged construction. Figure 12 shows a shaft of this type and gives the terms applied to the various elements.

The master- and articulated-rod assembly may be placed on the crankpin, the other portion of the crankshaft installed and

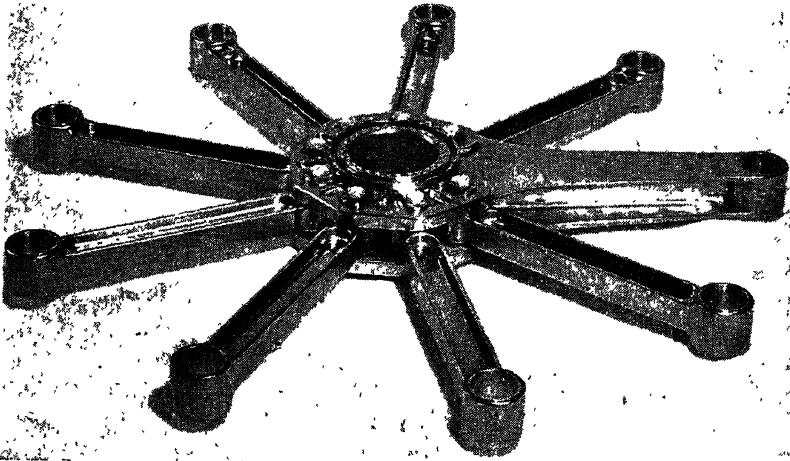

FIG. 11.—Articulated-rod system for a radial engine. (Wright Aeronautical Corp.)

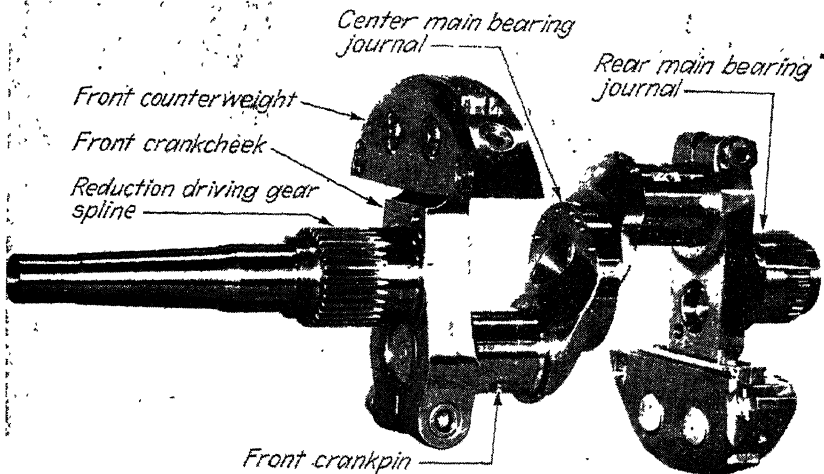

FIG. 12.—Crankshaft for a twin-row radial engine. (Wright Aeronautical Corp.)

aligned, and the clamp screw tightened. Alignment may be accomplished by inserting an *aligning bar* in a hole in one *crankcheek* (see Fig. 12) and moving the parts until the bar will pass

into a corresponding hole in the opposite *crankcheek*. The clamp joint is then tightened. The tension is checked by using a micrometer to measure the "stretch" of the clamp screw. Figure 13 shows a master rod assembled on a crankshaft for a single-row radial engine.

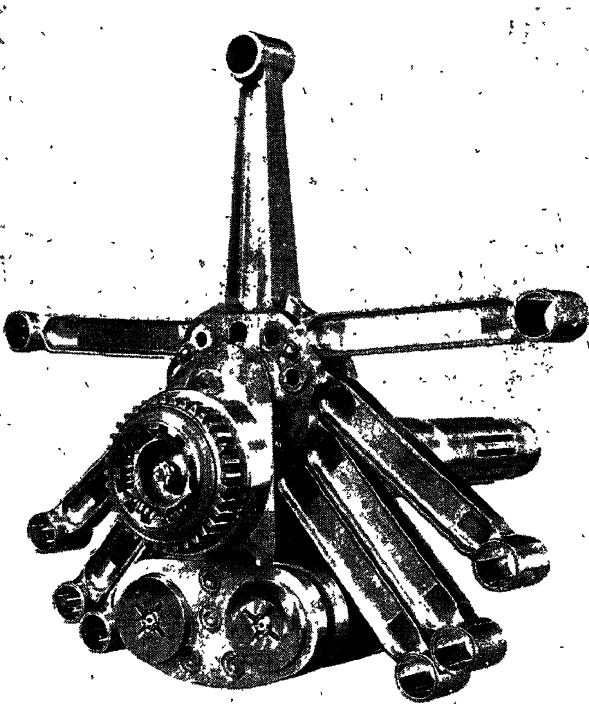

FIG. 13.—Master- and articulated-rod assembly installed on the crankshaft of a nine-cylinder radial engine. (*Pratt & Whitney Aircraft.*)

The rods and crankshaft are machined all over, the finished surface usually being ground and buffed. This is done to reduce surface-stress concentrations.

Pratt and Whitney engines employ two types of crankshaft and master rod. In some engines a one-piece crankshaft, which is somewhat more rigid than other types, is used. A split master rod similar to the rods used in conventional in-line engines must be used with this type of shaft. The other form of construction employs a one-piece master rod with a crankshaft divided inside the crankpin. A disadvantage of splitting the

master rod is that this increases its weight. Since the master-rod bearing is the most highly loaded bearing in the engine and since the loads on it are largely a function of centrifugal-inertia forces, any increase in weight of the master-rod assembly is usually avoided.

The important elements common to all types of crankshaft are shown in Fig. 12. Shafts are supported in *main bearings*. The cylindrical portion of the shaft, which rides in the main bearings, is called the *main-bearing journal*. The cylindrical portions on which the connecting rods ride are called the *crank-*

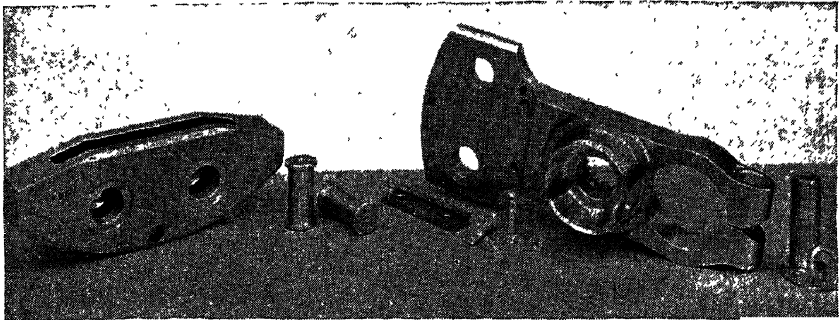

14.—Disassembled parts of a bifilar-type dynamic damper. (Wright Aeronautical Corp.)

pins. The roughly rectangular portions connecting the main-bearing journals and the crankpins are called *crankcheeks*. In single-row engines, the centrifugal-inertia force of the heavy articulated-rod system with its pistons is balanced by means of *counterweights* on each crankcheek. These counterweights may be rigidly attached to the crankcheek, or they may be suspended by means of *damper pins* to form a *dynamic damper*, which is a compound pendulum having the convenient characteristic that it reduces crankshaft torsional vibration. The counterweight in the foreground of Fig. 12 is of this type. Figure 14 shows the disassembled parts of the rear part of a crankshaft of this sort. Dynamic dampers will be discussed in the chapter on Vibration. In twin-row radial engines, the crankshaft is made as shown in Fig. 12, with only two counterweights, one on the front crankcheek of the *front crank throw*, the other on the rear crankcheek of the *rear crank throw*. No counterweights are needed in the center because the two articulated-rod systems balance each other.

The crankshaft of radial engines is usually supported in the crankcase by roller bearings. These bearings are normally installed with a tight fit of the inner race on the crankshaft and a loose fit of the outer race in the crankcase. Pratt and Whitney engines with one-piece crankshafts use plain main bearings, *i.e.*, simple sleeve steel-backed bearings lined with lead-bronze, silver, or other suitable bearing metal alloy. In twin-row radials with plain main bearings, the center portion of the crankcase must be

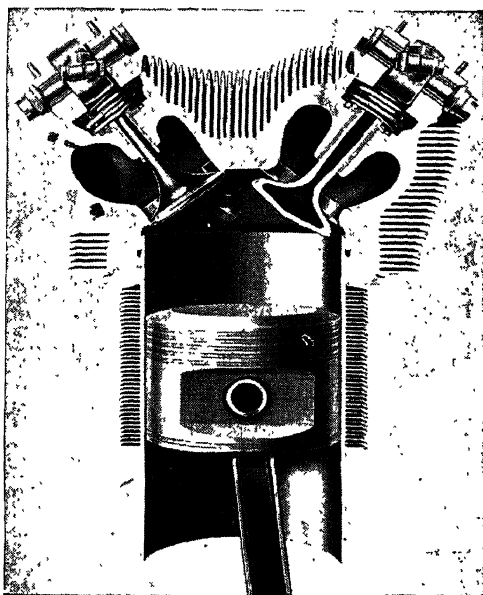

15.—Sectioned cylinder assembly for an air-cooled radial engine. (*Wright Aeronautical Corp.*)

split in half on a plane through the center line of the crankshaft. When roller bearings are used, this is not necessary; for the center main-bearing journal of the crankshaft may be made sufficiently smaller than the inner race of the roller bearing to permit assembly, and spacers can then be installed to take up the clearance between the two.

Cylinders.—The cylinders of a radial air-cooled engine are generally made of a cast-aluminum deeply finned cylinder head into which is screwed and shrunk a steel barrel. Cooling fins are ordinarily machined integral with the barrel as shown in Fig. 15. Cylinder barrels are made of either chrome-molybdenum or

nitralloy steel. Barrels made of the latter steel are *nitrided* to give the hardest and most wear-resistant type of casehardening known. The cylinder barrel is attached to the crankcase by means of an integral hold-down flange near the bottom of the cylinder barrel.

In the cylinder head are located the *valve ports*. The cylinder takes fresh charge in through the *intake port* and exhausts the burned gases through the *exhaust port*. Above each port is a *rocker box* in which is located the *rocker arm*. This actuates the tip of the *valve stem*, which extends up through the roof of the port into the rocker box. Into the cylinder head are screwed the spark plugs and the cooling-air baffle attaching screws. The cylinder head, being of soft aluminum, should have bronze inserts screwed into it to take these threaded parts. *Valve guides* of bronze or other alloy are also shrunk in to carry the valve stems. Valve seats, usually of alloy steel or aluminum bronze, are shrunk into recesses in the head. All these inserts, together with the studs for the attachment of the exhaust and intake pipes, are installed in the head while it is still hot after having been shrunk on the cylinder barrel.

Pistons and Piston Rings.—The pistons are aluminum-alloy forgings of heavy construction. They normally have a flat or nearly flat top surface. No bushing is used in the *piston-pin bore*. Most pistons are attached to the rod by means of a hollow *piston pin* of the floating type, *i.e.*, the type in which the pin is not locked in either the piston or the rod. End movement is restricted by means of *piston-pin retainers*. In Wright and Allison engines, these retainers are in the form of snap rings, which are sprung into a groove at each end of the piston-pin eye. Pratt and Whitney engines use dural plugs, which fit in each end of the piston pin. Spherical surfaces on the plugs contact the cylinder walls, to limit the end motion of the piston pin.

Piston rings must be used on the piston to prevent both leakage of gas from the combustion chamber into the crankcase and the passage of lubricating oil from the crankcase into the combustion chamber. Owing to high combustion-chamber pressures and temperatures, high piston speed, and high cylinder-wall temperatures, a good piston ring setup for highly supercharged air-cooled aircraft engines has been difficult to develop. Two principal types of piston rings are used, *compression rings*

intended to prevent gas leakage into the crankcase, and *oil-control*, or *oil-scraper*, rings intended to prevent passage of oil into the combustion chamber. The rings at the top of the piston are compression rings, while the ring immediately above the piston pin is an oil-scraper ring. An oil-scraper ring is also usually provided below the piston pin. In some engines, it is installed to scrape upward to provide a good film to lubricate the face of the piston.

Compression rings may be made with a square face as shown in Fig. 16a or with a tapered face as shown in Fig. 16b. Most rings

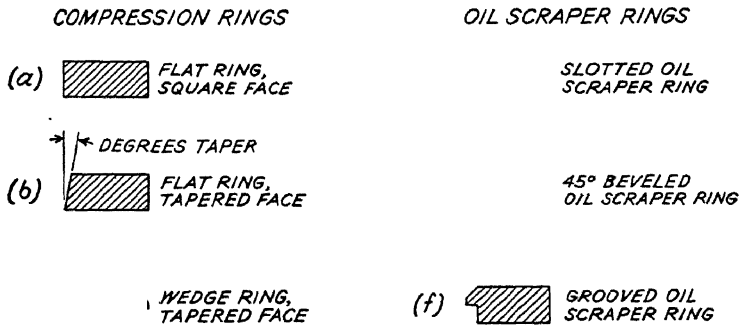

FIG. 16.—Types of piston rings.

in internal-combustion engines have had parallel sides as in the two examples shown. Operation with high cylinder-barrel temperatures tends to cause rings of this type to stick in their grooves. Wedge-type rings such as that shown in Fig. 16c have proved to be resistant to ring sticking. Because of this, they have come to be used in many engines.

Many types of oil-control rings have been employed. Grooved rings such as that shown in Fig. 16d have been used in all types of engine. Oil trapped in the groove may drain through slots into the space behind the ring. Holes drilled from this space through the wall of the piston allow the oil to return to the crankcase. A similar effect can be obtained by the use of a ring such as that shown in Fig. 16e. Sometimes two rings of this type are used together in a single wide groove. Compression rings have also been used as oil-scraper rings in some engines.

Valves.—Much development work has gone into the mushroom poppet valve used in aircraft engines.¹ The exhaust valve in particular has presented difficult problems owing to the high

temperature and corrosive characteristics of the exhaust gas and the relatively high stresses. High-chromium steels have been

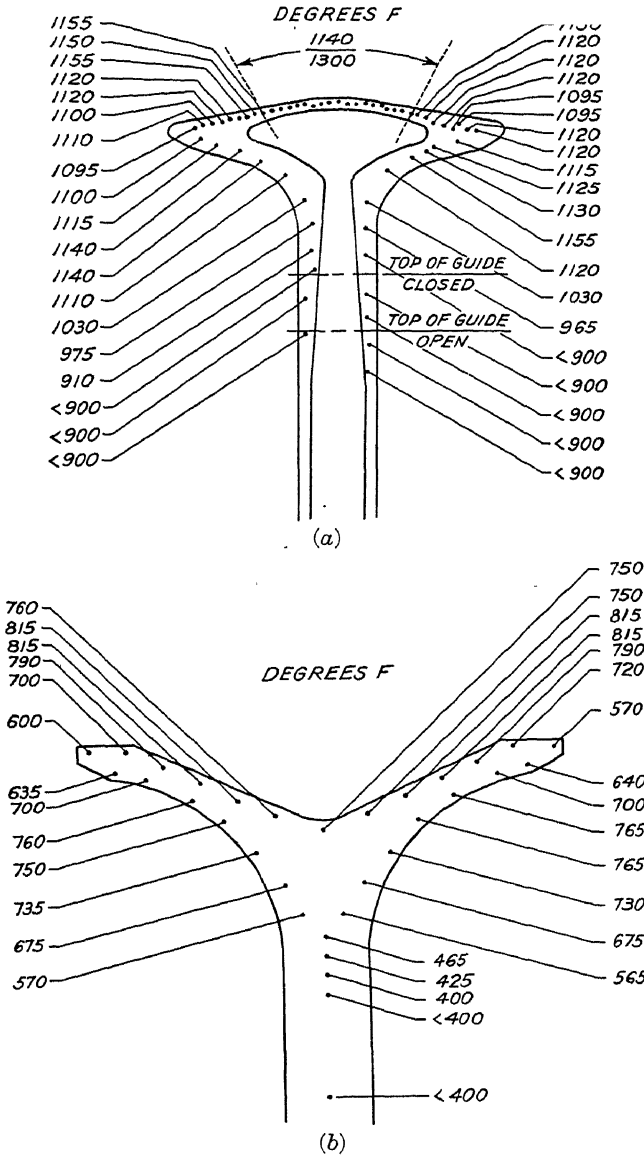

FIG. 17.—Operating temperatures of intake and exhaust valves of a large air-cooled engine. (Colwell, *Trans. S.A.E.*, vol. 35, 1940.)

found to be best for valves because they are corrosion resistant and they retain their strength well at elevated temperatures.

Even with such steels, valve heads would run too hot at high brake mean effective pressures (bmep's) if special provision for cooling were not made. It was found during the First World War that valve cooling could be accomplished through the use of hollow valve stem partly filled with salt. The salt melted as the valve heated up, splashed back and forth as the valve reciprocated, and thus carried heat from the valve head into the stem. There it was conducted through the valve guide to the cylinder head. Metallic sodium proved to be even more effective than salt as a coolant. Larger valves were then developed, with the

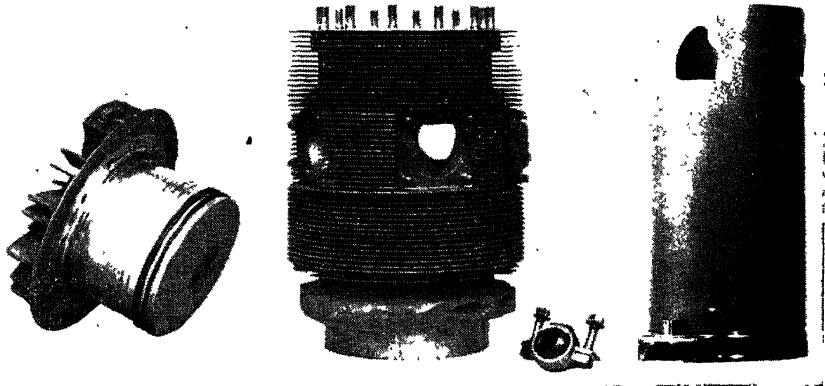

FIG. 18.—Bristol sleeve-valve engine cylinder head, cylinder, and sleeve. (*The Bristol Aeroplane Co., Ltd.*)

coolant cavity extended out into the head. A section through an exhaust valve for a high-performance radial engine can be seen in Fig. 17*a*. The small numbers show the operating temperature of the points indicated. Cooling is much less of a problem for intake valves; solid valves of special steel shaped like that shown in section in Fig. 17*b* have proved to be satisfactory.

Valves are installed in a "nest" of two or three helical valve springs so designed that each spring has a different natural frequency. This is necessary to help prevent surging of the springs, which will occur at speeds at which harmonics of the cam displacement curve correspond to the natural frequency of the valve spring.

Sleeve-valve Mechanisms.—All American aircraft engines employ mushroom nonbet valves such as that shown in Fig. 15,

but a number of successful engines have been developed with sleeve valves.² These make use of a sleeve in each cylinder that is operated by a small crank in the main crankcase. The combined reciprocating and turning motion imparted to the sleeve by the crank is used to cover and uncover the intake and exhaust ports, which are grouped around the periphery of the combustion chamber. Figure 18 shows the parts used in the British Hercules sleeve-valve radial engine. Much quieter operation and greater port area are the principal advantages of the sleeve valve. One of the important disadvantages is the difficulty involved in obtaining an effective seal between the sleeve and the cylinder head. A ring or set of rings similar to piston rings is used for this purpose. These rings, called *junk rings*, are prone to stick in their grooves and permit serious gas leakage from the combustion chamber.

Valve-actuating Mechanism.—The poppet valves are operated by *rocker arms* mounted on ball, or roller, *rocker bearings*, which are supported by *rocker bolts*. One end of the rocker arm is fitted with an adjusting screw, which is used to adjust the *valve clearance, i. e.*, the amount of "lost motion" in the valve-actuating mechanism. The rocker arm is actuated by the upper end of a *push rod*, which is enclosed in a *push-rod housing, or cover*. The lower end of the push rod rests in a spherical seat in the upper end of a *tappet*, which reciprocates in a *tappet guide* mounted in the crankcase. A roller revolving in the lower end of the tappet rides on the *cam*, which is in the form of a circular ring on which are a number of lobes (see Fig. 19). The cam revolves at some fraction of crankshaft speed, usually one-sixth or one-eighth. It may ride either on the crankshaft or on a cam bearing attached to and concentric with the crankcase. The latter is normally of bronze or other good bearing material. The cam is driven by a *cam-intermediate-drive gear and pinion*, which in turn are driven by the *cam-drive driving gear* on the crankshaft. In twin-row radial engines, one set of cam-drive and valve-gear parts is usually located in front of the front row of cylinders and the other set behind the rear row. This, of course, means that the front cylinder heads must be different from the rear cylinder heads since the intake ports must be at the rear of all the cylinders.

The intake ports of the cylinders are connected to the diffuser section by means of *intake pipes*. These are usually of aluminum

tubing and are attached to the diffuser section by means of a large packing nut at the base of each intake pipe. A flange is used to attach the outer end to the intake port of the cylinder head.

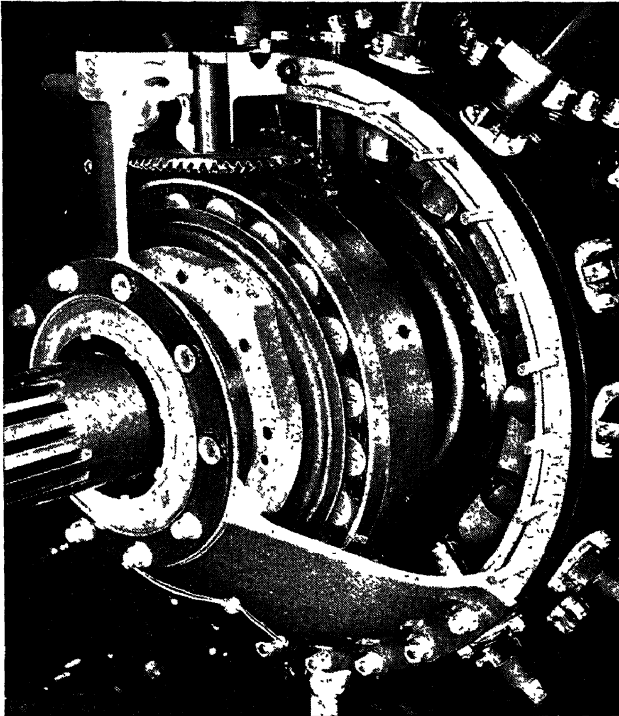

FIG. 19.—Sectional view of the reduction gear, cam, and tappets of a radial engine. (Wright Aeronautical Corp.)

Rear Section.—The general arrangement of the parts in the rear section can be seen in Fig. 20. A shaft, called the *accessory drive shaft*, extends forward from the front of the rear-section assembly and splines into the rear of the crankshaft. The accessory drive shaft is often referred to as the *starter shaft* because it is usually fitted at the rear end with a three-jawed clutch, which can be engaged by a corresponding member in the starter to motor the engine over. A gear at the rear end of this shaft inside the rear section drives the gear train of the supercharger impeller as well as the magneto-drive gears, the oil pump, and other accessories, such as a fuel pump, a vacuum pump, or a generator.

The various accessories are mounted on *pads* located on the rear section or in the *rear cover* and are equipped with shafts having splined, or tongued, ends, which fit into openings in the corre-

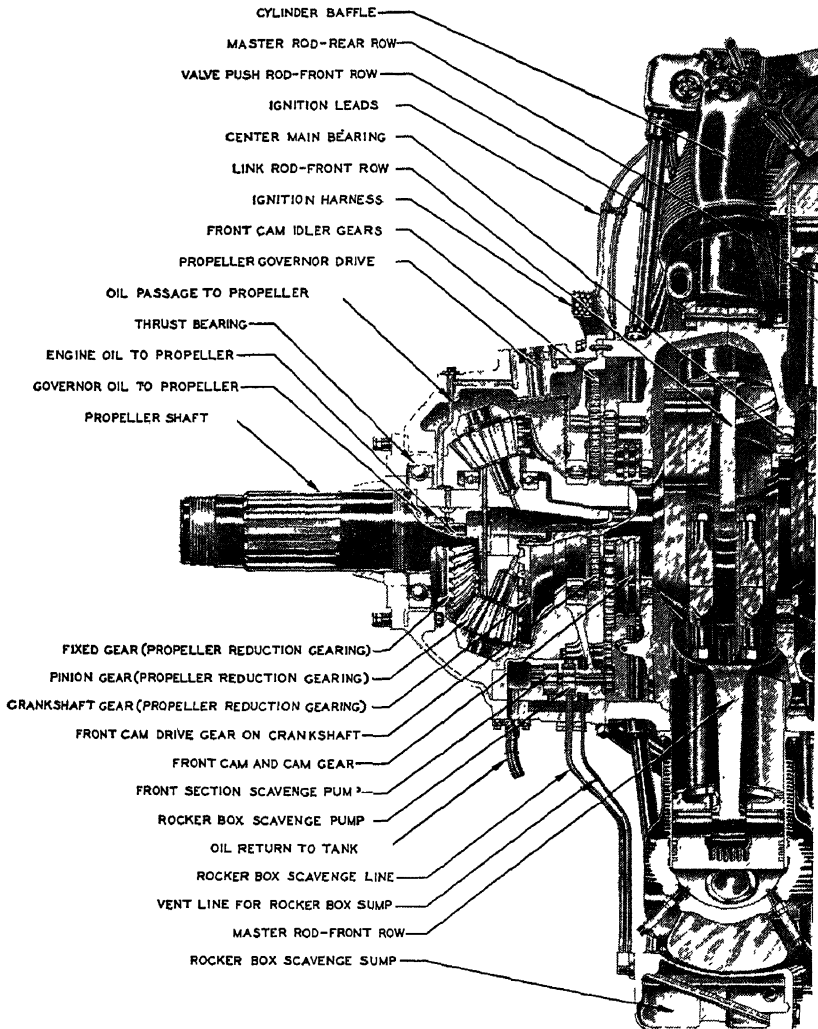
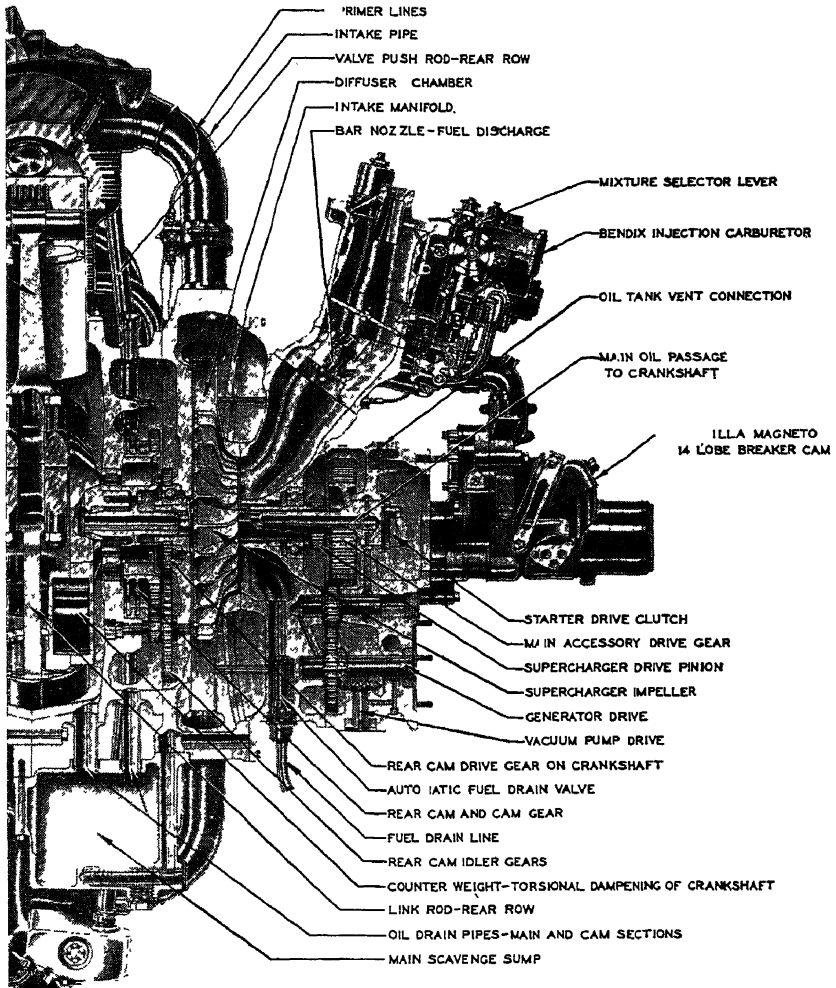

FIG. 20.—Longitudinal section through a Pratt and Whitney

sponding drive shafts in the rear section. These accessories are attached to their respective pads by means of studs. The supercharger *impeller shaft* is usually hollow and rides on journals pro-

vided for it on the accessory drive shaft. It splines into the impeller.

The principal parts of a supercharger are shown in Fig. 21. The impeller, shown in the center, rotates in the inner portion of



Twin-Wasp engine. (Pratt & Whitney Aircraft.)

the contoured plate at the left. The air flows from the periphery of the impeller into the vanes of the *diffuser* shown at the right.

Propeller Shaft and Reduction Gear.—Since it is possible to increase the horsepower of a given engine considerably by increas-

AIRCRAFT POWER PLANTS

ing the crankshaft speed, but since larger diameter propellers to absorb the increased horsepower must turn at lower speeds to preserve the same limiting propeller-tip speed, reduction gears have made their appearance and are now used in virtually all large engines. The simplest type for radial engines is a planetary system of spur gears in which the internal teeth of a large *driving gear* drive a number of small pinion gears, which are in mesh with a *stationary*, or *sun*, gear. These pinions rotate on trunnions,

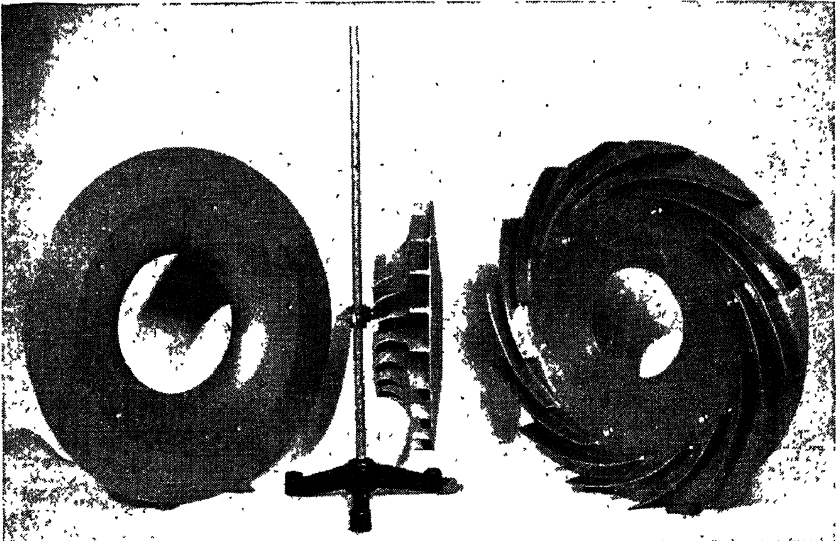

FIG. 21.—Supercharger impeller and diffuser. (Wright Aeronautical Corp.)

which are integral with or attached to the propeller shaft. The driving gear is splined to the crankshaft; and when it rotates, it carries the pinions, and thus the crankshaft, in the same direction but at a lower speed. Figure 19 shows a reduction gear of this sort. All current Wright reduction gears are of this type. Pratt and Whitney uses both the spur-type reduction gear just described and a bevel-type reduction gear. In the latter, a large bevel gear attached to the crankshaft drives a number of small bevel pinions mounted on radial trunnions on the propeller shaft. These are in mesh with a large stationary bevel gear similar to that driving them. A reduction gear of this type is shown in Fig. 20.

In Wright engines the propeller shaft rides on a forward extension of the crankshaft. End movement is restrained by a ball

thrust bearing located in front of the reduction gear. This bearing fits into a bearing-retainer ring in the nose section. In Pratt and Whitney engines the crankshaft does not extend forward beyond the driving gear on the crankshaft. Instead, the propeller shaft extends rearward and rides in a bearing inside the front portion of the crankshaft. This can be seen in Fig. 20. The thrust bearing is similar to that described above. Such an arrangement tends to isolate the propeller shaft from the crankshaft and may reduce the tendency for vibration to be transmitted from one to the other.

Various standard (S.A.E.) size designations are assigned to propeller shafts. Number 50 spline shafts are currently used on engines in the 1,000- to 1,600-hp class. High-pressure oil to operate Hamilton Standard constant-speed or hydromatic propellers is transmitted to the propeller shaft through sets of oil seal rings, which are called *hydro transfer rings*. The oil passes radially inward between the oil transfer rings and forward through the propeller shaft to a fitting at the front called a *transfer tube*. Oil may flow through this fitting to a propeller, or the fitting may be plugged for operation with propellers that do not require it.

Engine Assembly.—When an engine is to be reassembled, or *rebuilt*, after an overhaul, the first step is to bolt the blower housing to a mount. The rear part of the main case may then be attached to the blower housing. The articulated-rod system is assembled separately and installed on the crankshaft. In twin-row engines the center section of the main crankcase must be installed on the crankshaft before the latter is installed in the rear half of the crankcase. The whole assembly may then be picked up and lowered into the rear portion of the main crankcase. The front part of the main crankcase may be placed in position and the sections bolted together (see Fig. 22). Cylinder assemblies containing the valves and rocker arms can be installed to complete the assembly of the *power section*. The cam, cam drive gears, and reduction driving gear should be installed next. The *crankcase front section* is assembled with reduction gears and put in place as a unit. The *rear section* is assembled and installed in a similar manner.

The *ignition harness* may be installed at this point to prevent interferences. The *sump, push rods, baffles, and intake pipes* are

then installed, and the valve clearances are adjusted to the running clearance, *i.e.*, the value at which they should operate with the engine hot. After checking the valve timing, the clearances should be reset to give the proper cold clearance. This difference is caused principally by the change in length of the cylinder head and barrel and assembly as it heats up to operating temperatures. The *rocker-box covers* can be installed to complete the assembly

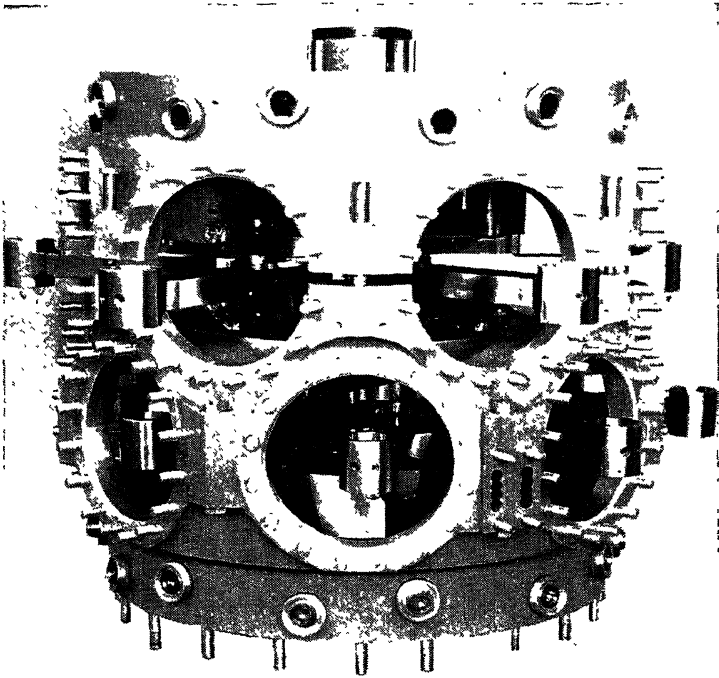

FIG. 22.—Main crankcase assembled with the crankshaft and articulated-rod systems of a twin-row radial engine. The front portion of the crankcase has just been lowered into place. (*Aluminum Company of America.*)

of the engine proper. The magnetos should be installed and timed at this point. Accessories and other equipment are also often installed in the engine overhaul shop if the latter is closely related to the shop in which the airplane is overhauled.

Fuel-metering Equipment.—Most American engines are fitted with carburetors for mixing the fuel with the induced air although many engines equipped with fuel-injection systems, which inject the fuel directly into the combustion chamber, are used in Germany. The carburetors are mounted on the rear section.

LIQUID-COOLED V-ENGINES

The Allison V-1710 (see Fig. 8) is the only liquid-cooled aircraft engine in production at the time of writing that has been developed solely in the United States. Used chiefly in pursuit planes, it is a 12-cylinder 60-deg V-engine having a 5.5-in. bore and a 6-in. stroke. Designed for ethylene glycol (prestone) cooling, it is supercharged and has good altitude performance. The

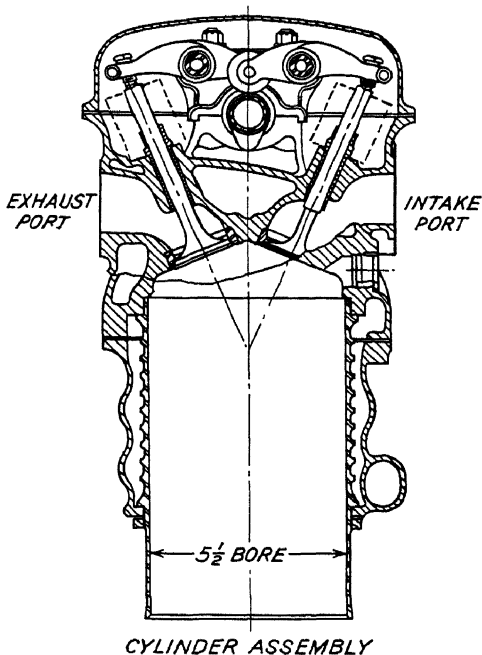

FIG. 23.—Section through Allison cylinder and valve mechanism. (Allison Division, General Motors Corp.)

British Rolls-Royce Merlin engine is similar to it in many respects. The engine may be considered as consisting of several major subassemblies, *viz.*, the cylinder blocks, the crankcase, the crankshaft and connecting rods, the reduction-gear assembly, the accessory drive housing, the intake manifolds, and the ignition harness.

Cylinder Blocks.—The cylinders are arranged in two banks, six in each bank. One long cast-aluminum head carries the overhead camshaft, valves, and valve mechanism as well as the spark plugs for each bank. Into it are shrunk the six cylinder barrels.

These are surrounded by an aluminum cooling jacket, a one-piece casting, which serves all six cylinders in the bank. Stainless-steel sleeves are slipped between each of the cylinder barrels and the coolant jacket to meter and direct the coolant flow over the cylinder barrels. The coolant jacket is attached to the cylinder head by many small studs placed at close intervals in the head, a leakproof joint being provided by the use of lapped mating surfaces. The joint between the cylinder barrel and the coolant jacket is sealed by a packing nut threaded to the barrel. Figure 23 shows a section through a cylinder-block assembly.

Four valves are used in the head of each cylinder, two intake and two exhaust. A roof-type combustion chamber is used, the axis of each pair of valves being inclined at an angle of $22\frac{1}{2}$ deg with the cylinder center line. The intake ports are on the inner side of the vee, and the exhaust ports are on the outside. The aluminum cylinder head is fitted with steel exhaust and bronze intake valve-seat inserts as well as bronze inserts for the spark plugs and valve guides.

The valve-operating mechanism can be seen in Fig. 23. Brackets that carry the camshaft and valve rocker arms are attached to the cylinder head by means of studs in the head. Two valve springs are used on each valve. A single lobe on the camshaft operates each rocker arm, which, in turn, operates two valves. Valve clearances are set by adjusting screws in the outer ends of the rocker arms. The aluminum cover that encloses the valve mechanism is attached to the head by means of small cap screws.

The pistons are aluminum-alloy forgings similar to those described under The Air-cooled Radial Engine. A hollow piston pin floats in the piston, end movement being limited by a snap ring at each end fitted in a groove in the piston. Five rings are used, three compression rings above the piston pin, and two oil-scraping rings in a single groove below.

Crankcase.—The cast-aluminum-alloy crankcase consists of three parts. Upper and lower halves are parted on the horizontal center line, while an oil pan is attached to the bottom of the lower half. Each cylinder-block assembly is attached to the upper half of the crankcase by means of 14 studs in the latter. These pass up through the cylinder head and transmit the loads set up by the combustion forces to the crankcase.

Crankshaft and Connecting Rods.—The six-throw crankshaft is supported in seven main bearings, the front one being a spherical roller bearing while the other six are of the plain sleeve type. Replaceable bearings having steel shells lined with bronze or silver alloy are used. All seven bearings are clamped between the two halves of the crankcase. The center main bearing is lined on its shoulders to locate the crankshaft axially. Each crank throw is counterweighted, while a pendulum-type dynamic

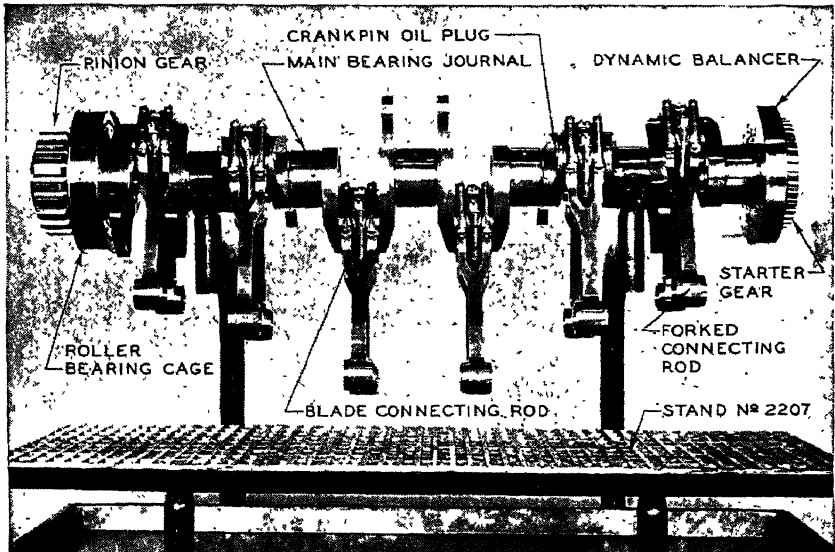

FIG. 24.—Allison crankshaft and connecting-rod assembly. (*Allison Division, General Motors Corp.*)

damper is provided at the rear end of the crankshaft to reduce torsional vibration. The connecting rods are of the fork-and-blade type, the forked rod being clamped to a bearing shell, which rides on the crankpin, while the blade rod rides on a layer of bearing material on the central portion of the outer surface of the same bearing shell. Bronze bushings are used in the piston-pin ends of the rods. Both the crankshaft and rods are finished all over. A view of the rods assembled on the crankshaft is shown in Fig. 24.

Reduction-gear Assembly.—Power is transmitted from the crankshaft to the propeller shaft through a pinion gear splined to the crankshaft. This drives an internal spur gear giving a

2:1 reduction-gear ratio. A friction-type torsional-vibration damper is incorporated in the C-15 engine. The reduction gears, propeller shaft, and friction-damper assembly are housed in a cast-aluminum reduction-gear housing. Axial thrust is taken by a ball bearing at the extreme front. A governor drive gear is also located in this housing, as well as a small oil scavenge pump.

Accessory Drive Section.—The accessories are driven from two different points. One shaft is geared to the rear end of the crankshaft. The starter is mounted on it, a three-jaw clutch connection of the standard type being used. The fuel, oil, and coolant pumps are driven from this shaft by bevel gears. Two other pads are provided for a generator and a vacuum pump. These pads are standard and take the same accessories as those used on radial engines. The other accessory drive shaft is driven by the large internal-reduction gear at the nose. It runs back along the top of the crankcase between the two banks of cylinders to the rear of the engine, where it drives the supercharger, the camshafts, the magneto, the distributors, the gun synchronizers, and the tachometer drive. The supercharger is mounted at the rear in a separate housing with the impeller-shaft axis parallel to that of the crankshaft. The camshafts are driven by two *tower shafts* with bevel gears at either end. Note that the accessories most susceptible to vibration are driven by the long flexible accessory drive shaft between the cylinder blocks. The supercharger impeller, in particular, must be driven by a shaft free of torsional vibration.

Induction System.—The engine is equipped with a Stromberg injection-type carburetor, which is mounted vertically on an elbow attached to the supercharger inlet. The air flows down through the carburetor, forward from the inlet elbow, and radially outward through the impeller and diffuser, and is then led off through a scroll to a point between the two banks of cylinders. From there a symmetrical intake-manifold system carries it to the intake ports. A backfire screen is placed in each half of the intake manifold to prevent backfire flames from further progress back through the induction system.

HORIZONTALLY OPPOSED CYLINDER ENGINES

In point of total numbers in service, the four-cylinder horizontally opposed engine is one of the most important types.

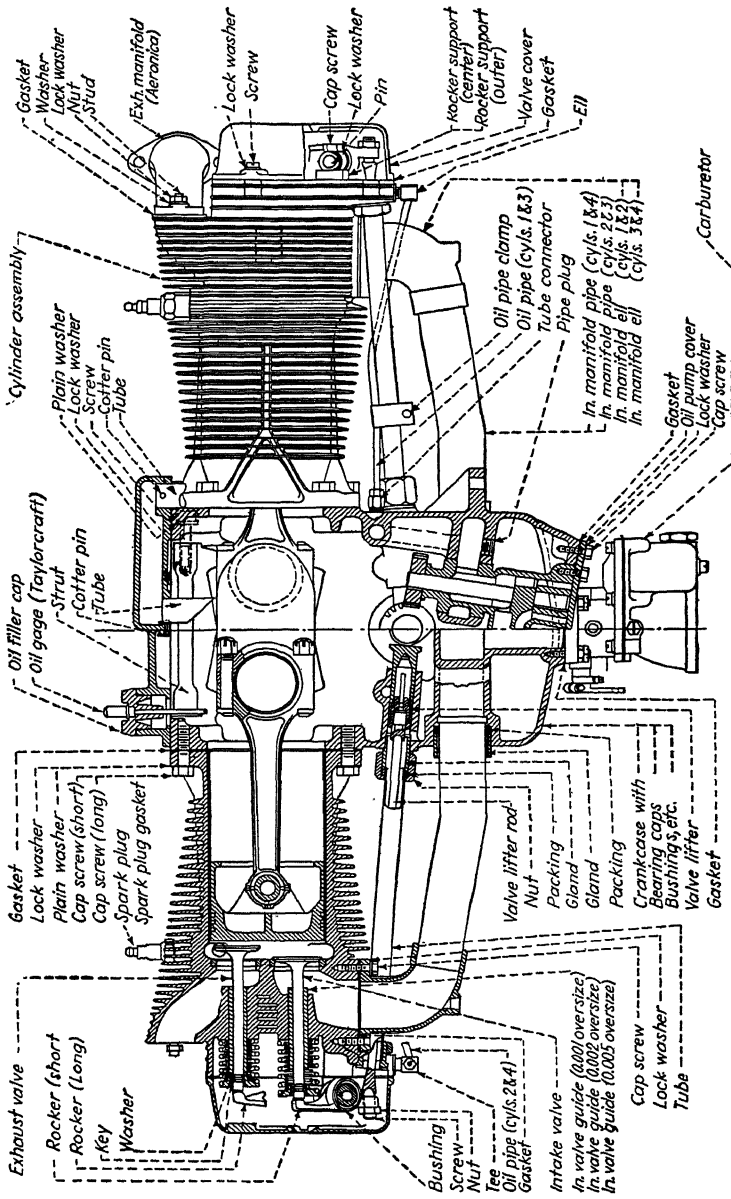

FIG. 25.—Section through a four-cylinder opposed engine. (Colvin, "Aircraft Handbook.")

It has proved to be the simplest and least expensive engine for use in small airplanes that require a power plant of 50 to 100 hp. The great success of the four-cylinder opposed engine in this field has led to the development of similar engines having six or eight cylinders and capable of as much as 200 hp. Most of these engines drive the propeller directly from the front of the crankshaft, although some of the higher power engines are provided with reduction gears.

Crankcase and Crankshaft.—The cylinders are arranged on either side of the crankshaft as shown in Fig. 25. A cast-aluminum crankcase is split on the vertical center line to take the crankshaft, which is supported in three plain main bearings. This arrangement permits close spacing of the cylinders to give a light compact crankcase and a short crankshaft. As in automotive practice, the crankshaft and rods are of steel and, to reduce costs, are finished only where necessary.

Cylinders.—The cylinders are usually similar to those used in radial engines except that cylinder barrels of alloy cast iron in place of forged steel are often used. The valve arrangement is also different in that the valves are usually placed with their stems parallel so that they seat in the top of a flat disk-type combustion chamber. The two rocker arms for each cylinder are housed together under a single cover. Enclosed push rods are operated by a camshaft located in the crankcase below the crankshaft.

Oil Sump and Induction System.—The oil sump is usually located beneath the crankcase in the form of a deep pan of cast aluminum. Cooling of the oil and heating of the mixture to assist in vaporization of the fuel are generally accomplished by the use of induction passages cast integral with the oil sump. Aluminum intake pipes are used to duct the fuel-air mixture from these passages to the intake ports of each of the cylinders.

Accessories.—Earlier engines of this type had little provision for accessories. Some of the subsequent models have provided for as much as two magnetos, a starter, a generator, a fuel pump, and a vacuum pump, all located at the rear of the crankcase.

IN-LINE AIR-COOLED ENGINES

The in-line air-cooled engine has had an important place in aircraft, particularly in units of 100 to 500 hp. The most widely used models have employed four or, more commonly, six cylinders

placed beneath the crankshaft to give an inverted in-line engine. The 12-cylinder inverted-V type gives an engine of exceptionally low frontal area for the power developed.

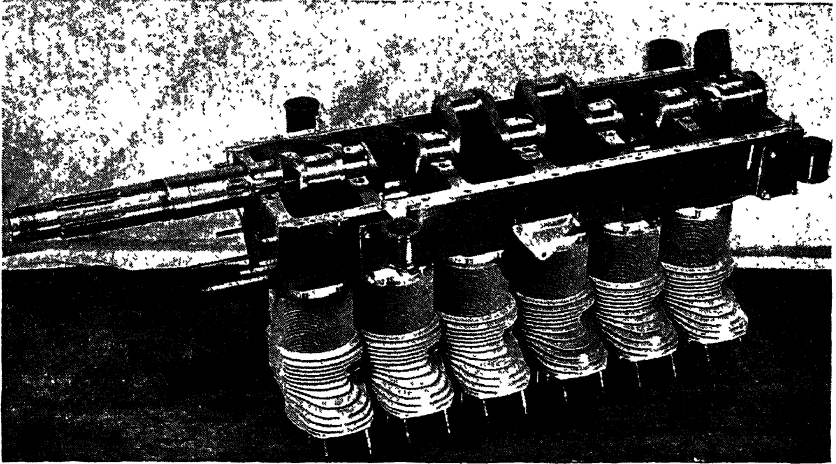

FIG. 26.—Crankcase and crankshaft of a six-cylinder in-line air-cooled aircraft engine. (*Ranger Aircraft Engines.*)

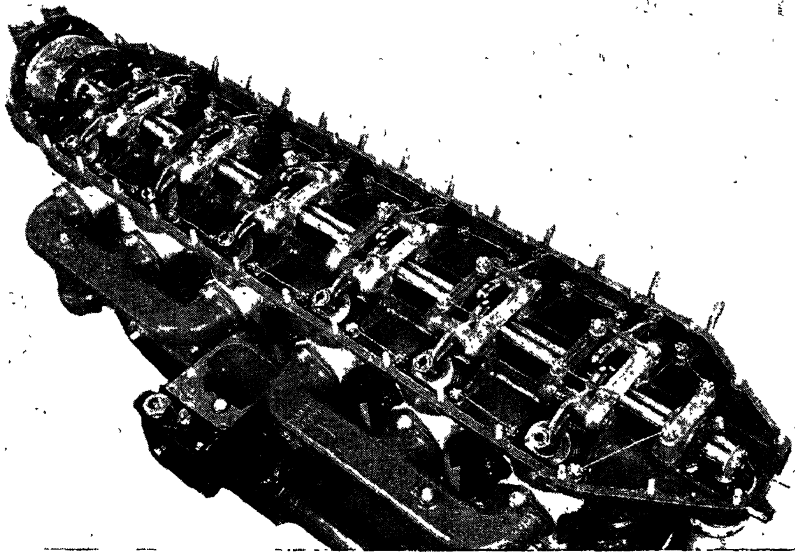

FIG. 27.—Camshaft and valve mechanism of a six-cylinder in-line engine. (*Ranger Aircraft Engines.*)

Crankcase and Crankshaft.—The crankcase is usually of cast aluminum or magnesium alloy split on the horizontal center line.

Plain sleeve-type main bearings are provided to support the crankshaft between each crank throw, as shown in Fig. 26. The inherent and almost perfect balance of the six-cylinder in-line engine gives smooth operation without counterweights on the crankshaft, thus making possible a reduction in weight.

Cylinders.—Cylinder construction and attachment to the crankcase are similar to those used in radial engines. The valves may be actuated by push rods operated by a camshaft in the crankcase, or the camshaft may be located in a housing attached to the cylinder heads. The latter arrangement gives a considerable increase in engine stiffness in the vertical plane. Figure 27 shows the cam, valves, and rocker arms, together with the provision for the adjustment of valve clearances, in an engine of this type.

Accessory Drives.—The crankcase rear cover is used to house the accessory drive gears and shafts. Drives are generally provided for the magnetos, fuel pump, generator, starter, vacuum pump, and tachometer. Figure 157 shows the location of the various drives on a typical engine.

CONSTRUCTION OF SPECIFIC ENGINES

The models developed by the various manufacturers differ in many of their details. Methods of assembly, part form and arrangement, provisions for adjustment, and especially cam- and accessory-drive gear systems often present distinctive features in particular engines. Tolerances on fits and clearances, on shaft end float, *i.e.*, the amount of axial "play," on valve clearances, etc., depend on the individual model. Aircraft-engine manufacturers have done a thorough job of preparing manuals giving instructions for the overhaul of each model engine. The most complete source of detailed information on a specific engine model is one of these manuals. An excellent summary of information on the construction and overhaul of the widely used engines is also available in book form.³

References

1. COLWELL, A. T.: Modern Aircraft Valves, *S.A.E. Trans.*, vol. 35, 1940.
2. FEDDEN, A. H. R.: The Single Sleeve as a Valve Mechanism for Aircraft Engines, *S.A.E. Trans.*, vol. 33, 1938.
3. COLVIN, F. H.: "Aircraft Handbook," 5th ed., McGraw-Hill Book Company, Inc., New York, 1942.

CHAPTER III

BASIC OPERATING PRINCIPLES AND DEFINITIONS

There are a number of relationships, principles, and terms that are basic to an understanding of aircraft-engine operation. The events of the cycle itself are fundamental. The thermodynamic processes involved are important, though because of their complexity, only the bare essentials are presented here. (For complete analyses, the student is referred to Taylor and Taylor¹

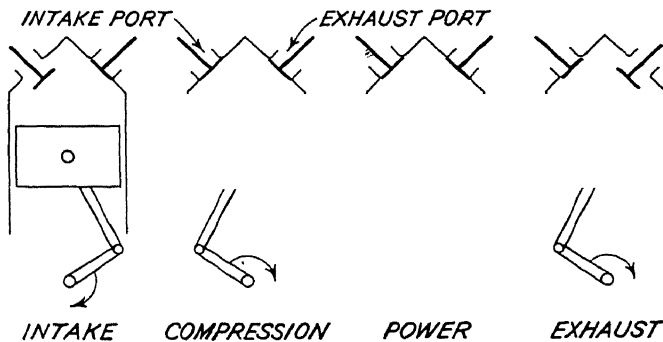

FIG. 28.—Piston and valve positions for each phase of the four-stroke cycle.

or to Lichty.²) These elements of internal-combustion-engine operation, together with the more important terms and equations commonly used in the industry, are covered in this chapter.

TWO- AND FOUR-STROKE CYCLES

Events in the Four-stroke Cycle.—The four-stroke-cycle spark-ignition engine is perhaps the simplest in principle of all prime movers. A piston reciprocating in a cylinder draws a mixture of fuel and air in through the intake valve during a downward stroke and compresses it on the subsequent upward stroke. An electric spark then occurs, which ignites the fuel-air mixture, releasing a considerable amount of heat, which, in turn, causes a large increase in pressure. Pushed downward by the pressure,

the piston delivers power to the crankshaft. When the piston reaches bottom dead center, the exhaust valve should open to allow the burned charge to leave the cylinder as the piston rises to push it out on the exhaust stroke.

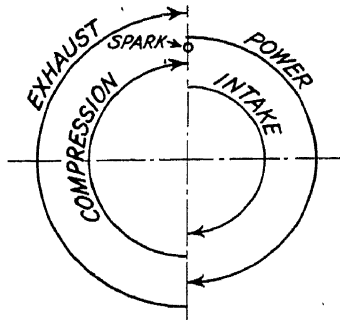

IDEAL TIMING

FIG. 29.—Ideal timing circle showing the sequence of events in the ideal four-stroke cycle.

Figure 28 gives a series of cross-sectional views through a cylinder. Each view indicates the crank, piston, and valve positions for each phase of the cycle. Figure 29 shows the complete cycle plotted as a "timing circle." This is a convenient representation for the sequence of events in the cycle.

Valve Timing.—In an actual engine the valves do not open or shut instantaneously because their inertia and that of the valve-actuating mechanism are considerable. As a matter of fact, getting the valves to open and close fast enough is one of the major problems in the design of modern high-speed poppet-valve engines. Since as much as 90 deg of crank rotation is required to open or close a valve, it has been found best to begin to open a valve early and allow it to close late as compared with the timing in the ideal cycle. The result is that the events in an actual engine cycle overlap. Figure 30 shows a timing circle for a typical engine. Note that the intake valve opens 15 deg earlier and closes 44 deg later than in Fig. 29. The exhaust valve begins to open 74 deg before bottom center (74°BBC) and closes 25 deg after top center (25°ATC). Note that there is an interval during which both valves are open at the same time.

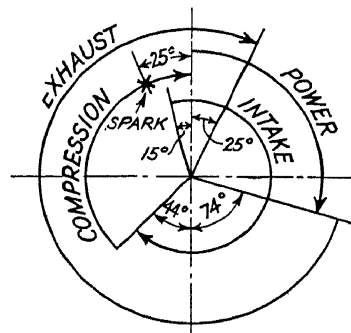

ACTUAL TIMING

INTAKE OPENS	15°BTC
INTAKE CLOSSES	44°ABC
EXHAUST OPENS	74°BBC
EXHAUST CLOSSES	25°ATC

FIG. 30.—Actual timing circle for a typical engine.

This is called *valve overlap*. If it is too great, backfiring may result, or an appreciable amount of the fuel-air mixture may pass directly from the intake port to the exhaust port. The table

below Fig. 30 shows the usual method of specifying the points at which the valves should open or close for service checks of a particular engine.

Spark Timing.—Another item of importance is the point in the cycle at which the spark occurs. Since it takes an appreciable time for combustion to occur, it is necessary to ignite the charge before the piston reaches top center if maximum power and fuel economy are to be obtained. The spark timing is usually specified as *spark advance* in degrees of crankshaft rotation before top dead center (see Fig. 30). This problem of ignition will be discussed later.

Events in the Two-stroke Cycle.—It is possible to eliminate the intake and exhaust strokes of the four-stroke cycle by exhausting, scavenging, and charging the cylinder while the piston is at or near bottom dead center. There are a number of ways in which this may be done, one of them being to place an exhaust poppet valve in the cylinder head and intake ports in the lower part of the cylinder walls. The exhaust valve would be timed to open considerably ahead of bottom dead center. By the time the piston had descended to the point where it began to uncover the intake ports, the pressure in the cylinder would have dropped to only a little more than atmospheric, so that air under pressure at the intake port might rush into the cylinder. The fresh air would push the remaining exhaust gas out the exhaust port and, at the same time, would fill the cylinder with a fresh charge so that the cycle might be repeated. On the surface, it would appear that this would permit double the power output from a given cylinder because it would double the number of power strokes obtainable at a given engine speed. While this is partly true, it is difficult to get fairly complete scavenging of the cylinder without allowing an excessive amount of fresh charge to escape with the exhaust. Even more important, the engine will operate satisfactorily at any particular speed at only one power output—any change in the engine-throttle opening would result in a change in air pressure at the intake port and thus a change in the rate of flow into the cylinder. This would cause poor scavenging. While there are ways of partly overcoming these difficulties, the complications have been such that the two-stroke-cycle engine has not been used for aircraft to any great extent.

THE WORK CYCLE

The Air Cycle.—The possibilities and limitations of the internal-combustion engine can be investigated best by a thermodynamic analysis. Inasmuch as the actual cycle makes use of a charge consisting largely of air, a first approximation to actual conditions may be obtained by considering a work cycle using air alone as a working fluid. One method of determining the work accomplished in each cycle is suggested by the fact that, if the piston moves a small amount, the work done is proportional

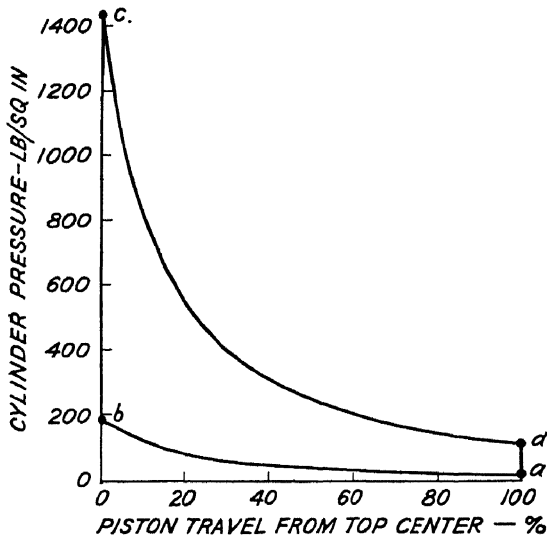

Fig. 31.—Pressure-volume diagram for the ideal air cycle.

to the product of the pressure acting on the piston and the distance moved. Since the pressure varies throughout the cycle, it is convenient to plot pressure against piston position, as in Fig. 31, and obtain the product of pressure and piston movement by taking the area under this curve. With ideal valve timing, adiabatic compression of a fresh charge of air would result in the curve *ab*, the abscissas of points *a* and *b* representing the volumes of the gases above the piston at lower and upper dead center, respectively. If a given amount of heat were added to the air with the piston at top dead center, the pressure would rise to point *c*. Adiabatic expansion of the air would be accompanied by a drop in pressure until the piston reached bottom dead center,

giving the curve *cd*. The exhaust valve would open at point *d*, and the hot gases would be discharged, giving the line *da*. A fresh charge would then be supplied to the cylinder, and the process could be repeated. Since the piston would do work on the charge during the compression stroke, the net work obtained from the cycle would be proportional to the area within the closed curve *abcd*.

The Fuel-Air Cycle.—Since the working fluid in the actual cycle is a mixture of fuel and air during the compression stroke and of nitrogen and the products of combustion during the expan-

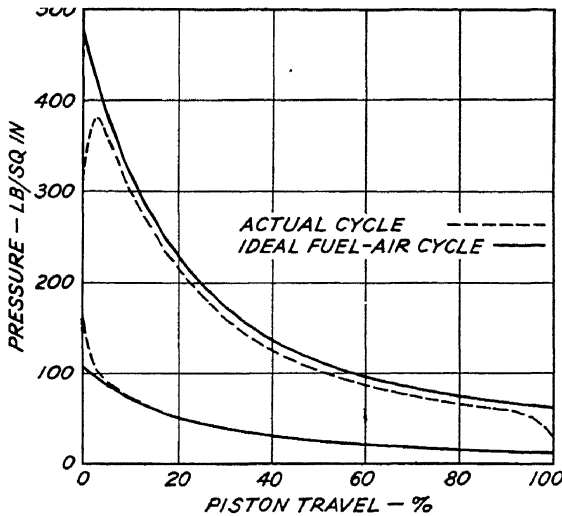

FIG. 32.—Pressure-volume diagrams for the ideal fuel-air cycle and for an actual cycle.

sion stroke, a closer approximation to the actual cycle can be obtained by basing the calculations for a diagram such as Fig. 31 on the thermodynamic characteristics of these gases. Since combustion is ordinarily never complete, owing both to the mixture being too rich or too lean and to molecular dissociation, the amount of heat added to the working fluid will be less than that theoretically available. Further, the specific heat of the products of combustion, *i.e.*, carbon dioxide and water vapor, is much higher than that of air. The result is that the temperature at the end of combustion and hence the pressure are decidedly lower than for the ideal air cycle (see Fig. 32). A compensating factor operating in the other direction is that the number of

molecules changes during combustion, giving, for most fuels, a larger total number at the end of combustion and consequently a tendency toward an increase in pressure for the actual cycle.

The Actual Cycle.—Figure 32 shows a diagram for an actual cycle superimposed on that of the fuel-air cycle. Such a diagram for an actual cycle is often called an *indicator card*. Its area is smaller, *i.e.*, it would give less useful work than the ideal fuel-air cycle. Incomplete combustion due to only partial mixing of the fuel vapor and air, together with heat losses to the combustion-chamber walls, causes the net amount of heat added to the charge to be less, so that the expansion curve falls at lower pressures than in the fuel-air cycle. Especially in high-speed engines, neither the process of combustion nor the exhausting of the burned charge can be carried out instantaneously, with the result that the corners of the diagram are rounded and a certain amount of energy is lost in this manner. A further loss results from the fact that not all the burned gases are discharged each cycle—some generally remain to mix with the fresh charge. The residual exhaust gas increases both the temperature and the average specific heat of the charge.

EFFECT OF OPERATING VARIABLES

Effect of Compression Ratio.—The compression ratio, *i.e.*, the ratio of the volume of gas in the combustion chamber with the piston at lower dead center to the volume with the piston at upper dead center, has a direct effect on the area of the indicator card, because it increases the pressures (see Fig. 32). The increase in indicator-card area with increase in compression ratio results in an increase both in the power obtained from one cycle and in the efficiency, for more work is obtained from a given energy input. Thus an increase in the compression ratio of an actual engine is accompanied by both an increase in power output and a decrease in fuel consumption. These increases are obtained at the expense of considerably increased pressures, which make it necessary to use heavier engine parts. Figure 33 shows the effect of compression ratio on fuel consumption, maximum pressure, and mep, *i.e.*, power output.

Effect of Spark Timing.—Since the time required for combustion amounts to 20 to 60 deg of crank rotation, it is desirable to have the spark occur before the piston reaches upper dead

center. If the spark occurred at upper dead center, combustion would not be complete until the piston had traveled some distance downward, and hence the indicator-card area would be greatly reduced (see Fig. 34). If, on the other hand, the spark occurred too soon, not only would the early pressure rise considerably reduce the indicator-card area, but the peak pressure for the cycle would be increased. The spark timing for maximum power can be readily established by testing the actual engine.

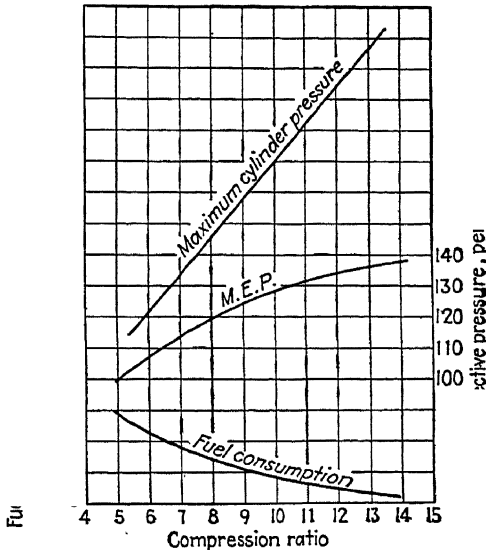

FIG. 33.—Effect of compression ratio on peak pressure, mep, and fuel consumption. (Meade, S.A.E. Trans., vol. 32, 1937.)

Effect of Valve Timing.—Early opening of the exhaust valve results in some loss in indicator-card area, but no more of a loss than would be caused by higher back pressures on the piston if it were opened later. The exhaust-valve closing is ordinarily timed to leave a minimum amount of burned gas in the cylinder to be used over in the next cycle. The inlet-valve opening and closing are timed to give a maximum amount of fresh charge for each cycle; for the pressures throughout the cycle are proportional to that at the beginning of the compression stroke, and the engine power output is proportional to these pressures. The optimum valve timing is also ordinarily determined by test work.

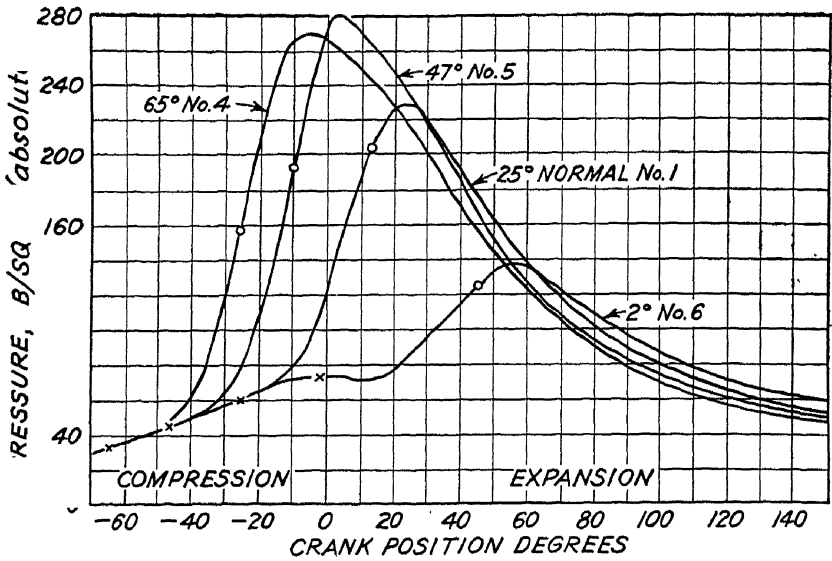
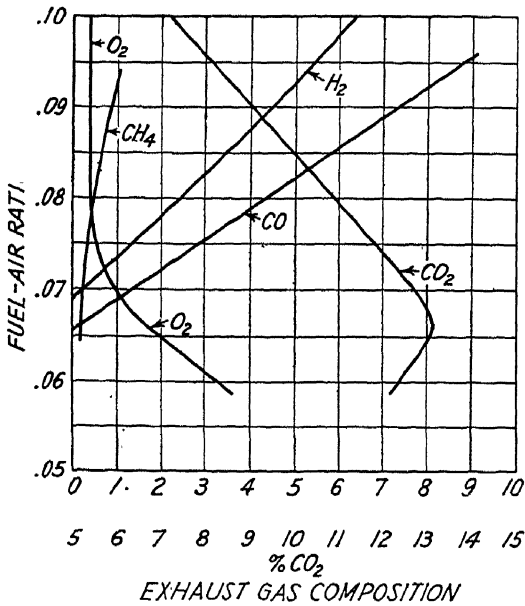

Fig. 34.—Effect of spark advance on the pressures in a cylinder. (Marvin and Best, N.A.C.A. Tech. Rept., 399, 1931.)



35.—Effect of fuel-air ratio on exhaust-gas composition. (Cambridge Instrument Co.)

Effect of Fuel-Air Ratio.—Changing the fuel-air ratio has a number of effects. The products of combustion vary in composition, as shown in Fig. 35. This variation causes a change in the pressures and temperatures developed during the cycle. In general, both the maximum temperatures and the maximum pressures occur near the theoretically correct mixture, but on the excess fuel, or *rich*, side owing in part to chemical-equilibrium

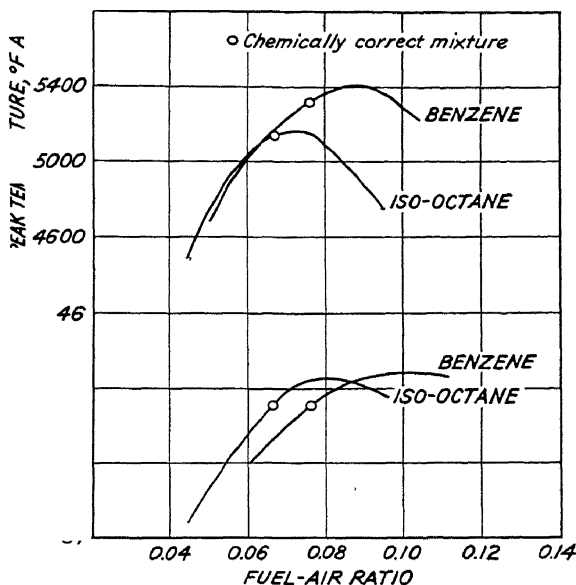

FIG. 36.—Effect of fuel-air ratio on calculated peak combustion temperatures and pressures for iso-octane and for benzene. (*Rothrock, S.A.E. Trans., vol. 49, 1941.*)

effects and in part to the greater increase in the number of molecules with combustion of the richer mixtures. That is, burning carbon to carbon monoxide instead of carbon dioxide gives half again as many molecules and a combustion product having a much lower specific heat, although only about 30 per cent of the amount of heat is released from a given weight of carbon. These effects hold even for extremely rich mixtures, so that they largely offset the effect on the pressures of the temperature decrease due to incomplete combustion. Figure 36 shows this effect for two different fuels. Of course, the amount of fuel consumed per cycle increases rapidly with the richer mixtures, giving correspondingly higher fuel consumption with

no increase in power. Note that both the maximum pressure and the maximum temperature also drop off for lean mixtures, *i.e.*, those containing an excess of air.

Effect of Pressure at the Intake Port.—Changing the pressure at the intake-valve port changes the density and hence the weight of the charge supplied to the cylinder each cycle. One way of looking at the effect of such a change is from the standpoint of the energy involved. The greater the weight of charge supplied to the engine, the greater will be the amount of heat released. Therefore, the engine power output should be directly proportional to the weight of the fuel and air flowing into the cylinder, *i.e.*, to the pressure at the intake port.

The indicator card makes possible a more detailed insight into the matter. Increasing the amount of the charge delivered to the cylinder each revolution by raising the pressure at the intake port results in a higher pressure in the cylinder at the beginning of the compression stroke. This higher initial pressure means proportionally higher pressures throughout the cycle and greatly increased indicator-card area, giving a correspondingly greater power output per cycle. Thus the engine power output can be varied by controlling the pressure at the intake port. This is ordinarily done by *throttling*, *i.e.*, by choking off the air supply to the engine. A "butterfly" or other type of valve is placed in the induction passages and connected to the throttle control lever. The engine can be operated at a particular speed at any power output between zero and that given with the throttle valve wide open, the power output being at all times a function of the pressure at the intake port.

Effect of Supercharging.—A blower can be used to pump air into the engine. By raising the pressure at the intake port to a value considerably above atmospheric, the weight of charge delivered to the cylinder at full throttle can be increased to give an almost proportional increase in engine-power output. This is called *supercharging*. It has been so successful as a method of increasing engine power capacity that all the larger aircraft engines are now supercharged.

DEFINITIONS AND FORMULAS

Engine Data.—Certain data are commonly used in describing an engine. The internal diameter of the cylinders, or *bore*,

the distance traveled by the piston between upper and lower dead centers, or *stroke*, and the number of cylinders in the engine are indications of the engine size. All three of these determine the *piston displacement*, which gives the best single indication of the engine power capacity. The bore, stroke, and displacement are given in terms of inches. The compression ratio is also given and may be checked by measuring the amount of oil that may be poured into a cylinder through a spark-plug hole with the piston at upper dead center. The volume thus obtained, when added to the volume calculated from the bore and stroke, gives the volume above the piston at bottom dead center. The ratio of this sum to the volume at upper dead center gives the compression ratio. The valve and spark timing are other items normally included.

Power Indices.—Engine power output is commonly given in terms of horsepower delivered at the propeller shaft, *i.e.*, brake horsepower (bhp). The amount of power developed in the cylinders as given by an indicator card is equal to the brake horsepower plus the friction horsepower required to motor the engine at the same speed with the cylinders not firing. The *indicated horsepower* (ihp) thus obtained, either from indicator cards or from addition of brake and friction horsepowers, is used in the analysis of engine performance.

Cylinder Pressures.—The pressures in the cylinder are important from several standpoints. One index of these pressures is the *mean effective pressure* (mep). This is the pressure in pounds per square inch which, when multiplied by the number of power impulses per minute, the piston area, and the length of the stroke, will give the power output of the cylinder. In a four-stroke-cycle engine the mep would be given by

$$\text{mep} = \frac{\text{rpm}}{2} \times \frac{\text{stroke}}{12} \times \text{piston area} \times \text{no. of cylinders} \times \frac{\text{hp} \times 33,000}{\text{rpm} \times \text{piston displacement}} \quad (1)$$

where the stroke and piston area are given in inches. The rpm is divided by 2 because a power stroke occurs only once every other revolution in each cylinder. If based on brake horsepower, the *mean effective pressure* would be called *brake mean effective*

pressure (bmep); if based on indicated horsepower, it would be called indicated mean effective pressure (imep). It should be noted that the bmep is directly proportional to the torque output at the propeller shaft.

The maximum pressure developed during a cycle is often important, especially from the standpoint of stresses in engine parts. It is referred to as the *peak pressure*.

As was shown previously, the mep is a function of the pressure in the intake manifold. Since this pressure may be either above or below atmospheric, it is expressed in terms of absolute pressure in inches of mercury, and is called *manifold absolute pressure* (map). The British often refer to this pressure as "boost," expressing it in the same units.

Efficiency Criteria.—A number of different "efficiencies" have been used as criteria of engine performance. One is the *over-all thermal efficiency* and is simply the brake-horsepower output divided by the energy, or heating value, of the fuel supplied to the engine. Both must be measured in the same units, of course. The *cycle efficiency* is that given by dividing the power from the ideal indicator card for the fuel-air cycle by the heat energy in the fuel used. It indicates the efficiency one might hope to approach. The *mechanical efficiency* of the engine is the brake horsepower divided by the indicated horsepower. The *volumetric efficiency* of a four-cycle engine is the ratio of the volume of air that flows into the engine every two revolutions divided by the piston displacement.

All of the above criteria of efficiency are generally of interest only to power analysts. For practical purposes, the item of most importance from the efficiency standpoint is the amount of fuel that an engine will consume in producing 1 hp for a given period of time. This characteristic is spoken of as *specific fuel consumption* and is given in terms of pounds of fuel per horsepower-hour. If based on brake horsepower, it is called *brake specific fuel consumption* (bsfc); while if based on indicated horsepower, it is called *indicated specific fuel consumption* (isfc).

References

1. TAYLOR, C. F., and E. S. TAYLOR: "The Internal Combustion Engine," 1st ed., International Textbook Company, Scranton, Pa., 1938.
2. LICHTY, L. C.: "Internal-combustion Engines," 5th ed., McGraw-Hill Book Company, Inc., New York, 1939.

CHAPTER IV

COMBUSTION

The combustion process imposes definite limitations on engine power output from the standpoint of both engine design and, especially, actual operation in the airplane. The problem as a whole is made complex by the many variables involved. A general picture of combustion and the essential factors limiting power output are presented here to give a working understanding of the effects of combustion on engine operation.

TYPES OF COMBUSTION

Normal Combustion.—Combustion is a complex phenomenon. Essentially it is a chemical reaction between a fuel and oxygen, the reaction being accompanied by a considerable release of heat. In the internal-combustion engine, this heat is developed at a point in the engine operating cycle such that power is obtained from the heat released. Although the popular conception of the combustion process in an engine is that of an “explosion” in which the burning process is instantaneous, under normal operation this is not the case. A flame front originates at the spark plug and progresses at a finite rate across the combustion chamber. Progress of this flame front is accompanied by the release of heat, which causes a pressure rise. The latter acts on the piston to deliver power to the crankshaft.

Flame propagation and pressure rise have been studied with both bombs and actual engines.¹ The results have shown that the flame front progresses radially outward from the spark plug, traveling first at a low speed, then accelerating, and finally slowing down as the last part of the charge is reached. This change in flame-front velocity is due principally to the fact that the burned portion of the charge expands considerably, pushing the gases in the flame front outward and causing the latter to accelerate. Figure 37 shows two views of the combustion chamber of a single-cylinder engine. A set of “contour lines” indi-

cating the flame-front position at intervals of 5 deg of crank rotation after the spark occurred are sketched in. The wide intervals between the 15- and 30-deg positions indicate more rapid flame movement than do the intervals between the 5-, 10-, and 15-deg lines.

The velocity of the flame front is affected somewhat by many factors, including the fuel used, fuel-air ratio, amount of residual exhaust gas, water-vapor content of the charge, and temperature. By far the most important factor, however, is the air velocity

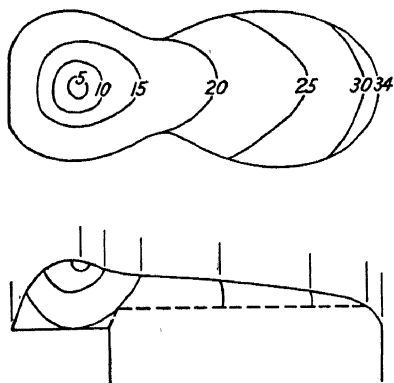

FIG. 37.—Flame front positions at 50 intervals of crank rotation in a spark-ignition engine. (*Marvin, Wharton, and Roeder, N.A.C.A. Tech. Rept. 556, 1936.*)

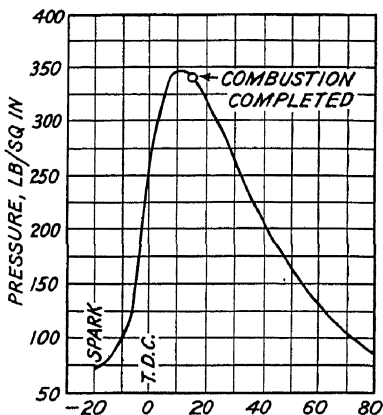

FIG. 38.—Indicator card taken at the same time as the data for Fig. 37 was obtained. (*N.A.C.A. Tech. Rept. 556, 1936.*)

through the intake-valve port, which causes “fine-grain” turbulence in the combustion chamber. Since air velocities through the intake port increase with rpm, this factor increases the speed of the flame front so that the flame speed increases with engine rpm. This effect is great enough so that it largely offsets the effect of rpm on the number of degrees of crank rotation required to burn the charge. That is, if the time required for combustion occupies 40 deg of crank rotation, doubling the rpm will often give only 50 deg of crank rotation required for combustion instead of the 80 deg that would be necessary if the flame speed remained constant.

The pressure developed by the burned charge increases at essentially the rate indicated by theoretical considerations based

on the flame-front velocity across the combustion chamber. Figure 38 shows a plot of cylinder pressure against crank angle from an indicator card made at the time the data for Fig. 37 were obtained. With normal combustion such as this, the rate of pressure rise is not so rapid that excessive impact loads on the piston and cylinder head occur, and the engine runs smoothly. If the combustion rate were so great that the gas forces struck the piston abruptly, the whole engine would be jarred and one type of *rough* operation would occur.

Preignition.—Mixtures of fuel and air have some characteristics that prevent combustion from proceeding in the orderly manner described above. One of these is spontaneous ignition, which will occur if the mixture temperature is raised to a sufficiently high value. In an actual engine, this means that a "hot spot" such as a spark plug or an exhaust valve may raise the temperature of the mixture in its vicinity to such an extent that the mixture will ignite spontaneously. Ignition in this manner may occur before the ignition spark, or it may occur in some remote portion of the combustion chamber before the charge there has been reached by the flame front. Since the unburned charge is compressed and hence its temperature is raised by expansion of the burned portion, it may easily reach the critical temperature and ignite spontaneously as it is compressed and before it is reached by the flame front, especially if there are local hot spots in the walls of the combustion chamber. This spontaneous ignition results in the formation of a new flame front, which progresses outward from the source in exactly the same way as does the flame from the spark plug. Combustion occurring in this manner is called "preignition."

The principal objection to preignition is that the timing of the resulting combustion is uncontrolled. Once started, preignition tends to grow worse rapidly since the hot spot responsible grows hotter, in effect giving a still more advanced combustion timing. If the ignition switch is turned off when preignition occurs, the engine may continue to run, the hot spot serving to ignite the charge. Operation after the switch is cut is called "afterfiring." Usually the engine will begin to cool when the switch is cut, so that the cylinder may fire only a few times and then stop. The number of times it fires after the switch is cut is a measure of the severity of the preignition.

The effects of preignition are exactly the same as those of an overadvanced spark: the engine loses power and overheats. The latter is particularly serious in air-cooled engines in which the installation may provide scarcely enough cooling for normal operation. The overheating accompanying preignition may damage the engine by causing cylinder-wall lubrication to fail, so that scoring of the cylinder or the piston, or both, results.

Detonation.—Another abnormal condition that may arise is “detonation.” This is an abrupt and violent explosion of the unburned portion of the charge when its temperature and pressure reach critical values. Unlike either normal combustion or preignition, the pressure rise when detonation occurs is so rapid that no one has succeeded in measuring it. National Advisory Committee for Aeronautics (N.A.C.A.) tests show that it takes place in less than $1/40,000$ sec.² Not only does the pressure rise to extreme values, but it fluctuates violently at high frequency. These pressure fluctuations literally hammer the walls of the combustion chamber, causing the audible “knock” or “ping” commonly heard in automobiles and ordinarily associated with detonation. Unfortunately, the noise caused by detonation in aircraft engines is drowned out by propeller, exhaust, and mechanical noise, and there is thus no sonic warning.

Figure 39 shows frames from high-speed motion pictures taken by a special process at the N.A.C.A. laboratories. The pictures were taken through a window looking down into the right side of the combustion chamber of an engine designed for that purpose. The series of pictures at the top are of normal combustion. A flame front started by the spark plug on the left side of the cylinder is shown progressing toward the right of the combustion chamber in a controlled and orderly fashion. Note that except for the last frame the pictures shown for normal combustion were separated by equal time intervals.

To show the process in greater detail, the frames of knocking combustion, shown in Fig. 39*b*, were, except for the last two frames, separated by just one-half the time interval chosen in Fig. 39*a*. Comparison of the two sets makes it evident that under conditions of normal combustion it would have taken about 0.002 sec for combustion to reach completion after the second-last frame in Fig. 39*b* was taken. But when detonation occurred, the pictures show that combustion was complete only 0.000025 sec

later. The last frame also shows blurring of the image, particularly at the lower right, because of the brilliant light emitted by the detonating portion of the charge. Note too that the unburned charge darkened just before it detonated.

Sketches of pressure-time records for both normal and knocking combustion are shown at the right of Fig. 39*b*. The upper sketch shows the uniform rate of pressure rise that occurs under conditions of normal combustion such as are shown in Fig. 39*a*. The abrupt and virtually instantaneous pressure rise, followed by violent pressure fluctuations, that accompanies detonation is shown in the lower sketch. The frequency of these pressure fluctuations is actually much greater than is indicated by the sketch, so that a much larger diagram would have been required to show it clearly.

Effects of Detonation.—Detonation is invariably accompanied by severe stressing of engine parts, particularly the cylinder head, piston, and valves. Stresses in these parts increase rapidly with increase in the severity of detonation, owing both to the higher peak cylinder pressures and to the fact that the loads due to detonation are applied so suddenly as to be really "shock," or "impact," loads. Further, regardless of knock intensity, the violent high-frequency pressure fluctuations that always accompany detonation cause what might be referred to as "accelerated-fatigue" failures. While the number of stress cycles required for the rupture of a cylinder head under detonating conditions, for example, is generally far less than the number ordinarily associated with fatigue in metals, the character of the failure is essentially the same. Some point of stress concentration serves as a nucleus; a small crack forms and spreads rapidly through the part. In addition to the pressure fluctuations accompanying detonation, the surfaces in the vicinity of the portion that detonates tend to overheat. "Burning" of aluminum cylinder heads and pistons may proceed to the extent that a hole may be burned through the piston. Even light detonation will weaken a piston and have destructive effects on the rings.

No internal-combustion engine, no matter how heavily built, can be operated under conditions of heavy detonation for long periods of time without serious damage to engine parts. Since aircraft engines are designed to keep weight to a minimum, there is little strength margin to take care of the high temperatures

and stresses of even light detonation. Therefore, detonation imposes perhaps the most important limit on engine operation—*conditions must always be adjusted so that detonation does not occur, or damage to the engine will result.*

Detonation tends to cause a loss in power because of the energy losses accompanying the violent pressure fluctuations. The loss in power output, however, is usually small and is not noticeable under conditions of light detonation.

FACTORS AFFECTING DETONATION

Detonating Characteristics of the Charge.—The detonation characteristics of fuels vary widely. The problem is greatly complicated by many engine conditions. Rothrock and Biermann have shown that all these factors may be evaluated in terms of their effect on the pressure and temperature of the last part of the charge to burn.³ Further, the maximum temperature and pressure to which a particular fuel-air mixture may be raised without detonation depend on the fuel.³ Some fuels are sensitive to temperature, others to pressure. The fuel-air-mixture ratio may also have a marked effect, the richer mixtures detonating only at considerably higher temperatures and pressures than the best power mixtures. Dilution of the charge by exhaust gas between the exhaust and inlet strokes, as well as atmospheric humidity, are other factors that may have an appreciable effect on the tendency of the charge to detonate.

Factors Determining the Critical Temperature and Pressure.—Many engine conditions have a direct effect on the temperature and pressure of the last portion of the charge to be burned, the part most likely to detonate. The most important of these are as follows:

1. Compression ratio.
2. Inlet air pressure.
3. Inlet air temperature.
4. Temperature of combustion-chamber walls (*i.e.*, cylinder head).
5. Spark advance.
6. Engine speed.
7. Combustion-chamber size and shape.
8. Combustion-chamber deposits.

The effects of these items are interrelated. The only satisfactory method of investigation is to study each separately, holding the other items constant.

Compression Ratio.—Any expression for the knock resistance of a fuel must be relative, for it is only the point at which detonation begins that is significant. Since factors affecting the *pressure* of the last part of the charge to burn vary the most widely, a measure of the critical pressure is most significant. Since this

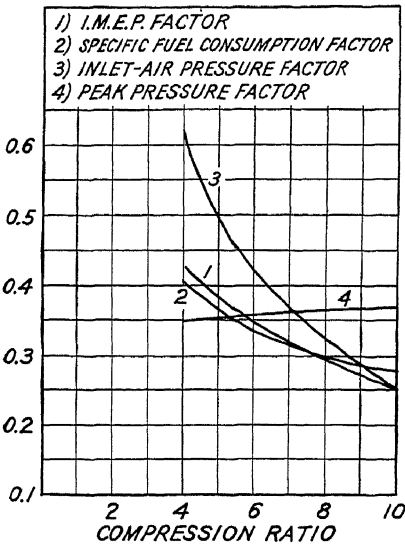

FIG. 40.—Effect of compression ratio on maximum permissible performance factors. (Rothrock and Biermann, *N.A.C.A. Tech. Rept. 622, 1939.*)

pressure depends directly on compression ratio, a convenient method of approaching the critical point from the non-knocking range is by varying the compression ratio of an engine designed for that purpose. Under a given set of operating conditions, the compression ratio causing light detonation can be determined. The higher the compression ratio obtainable without knocking, the greater the detonation resistance of the fuel being tested.

Manifold Pressure.—It was pointed out in the preceding chapter that obtaining a given increase in imep by going to higher compression ratios will give much larger peak pressures than would be obtained if the power increase were gained from increased supercharging. Therefore, in the spark-ignition engine operated to give the maximum power obtainable without detonation a net gain in power with a reduction in peak pressure can be obtained by using a lower compression ratio and a higher supercharge. The lower peak pressure reduces both the stresses in engine parts and the tendency of the fuel-air charge to detonate. Figure 40 shows the effect of compression ratio upon a factor proportional to the maximum permissible pressure in the intake manifold, *i.e.*, the maximum amount of supercharge that can be used at each compression ratio without detonation. The curve

Under a given set of operating conditions, the compression ratio causing light detonation can be determined. The higher the compression ratio obtainable without knocking, the greater the detonation resistance of the fuel being tested.

It was pointed out in the preceding chapter that obtaining a given increase in imep by going to higher compression ratios will give much larger peak pressures than would be obtained if the power increase were gained from increased supercharging.

COMBUSTION

is based on temperatures in the intake manifold that would be given by an average carburetor-supercharger combination with standard sea-level carburetor air inlet conditions. Factors directly proportional, respectively, to the peak pressure, the imep, and the specific fuel consumption are also plotted. Note that the peak pressure is practically unaffected, while both the imep and the specific fuel consumption increase with decreasing compression ratio.

Spark Advance.—Spark advance is also important. The spark is usually timed so that combustion is complete by about 15 deg of crank rotation after top dead center. This is done so that combustion of the last bit of the charge is carried out at considerably lower temperatures and pressures than would be the case for the maximum-power spark advance (see Fig. 34). In this way, detonation may be avoided, and more power may be obtained by going to higher intake manifold pressures. Figure 41 gives the effect of spark advance on the maximum permissible manifold pressure that can be used without detonation, together with the specific fuel consumption and imep for a single-cylinder engine. It shows quite clearly how the maximum power obtainable without detonation can be increased by retarding the spark. Operation with a 20-deg instead of a 30-deg advance would permit a 35 per cent increase in power. This is the reason why aircraft engines are operated with a spark advance considerably less than that for maximum power. The 10 per cent increase in specific fuel consumption at high speeds and powers is not a serious price to pay in the high-power range, for operation there represents only a small portion of the normal running time. The loss in power and the increase

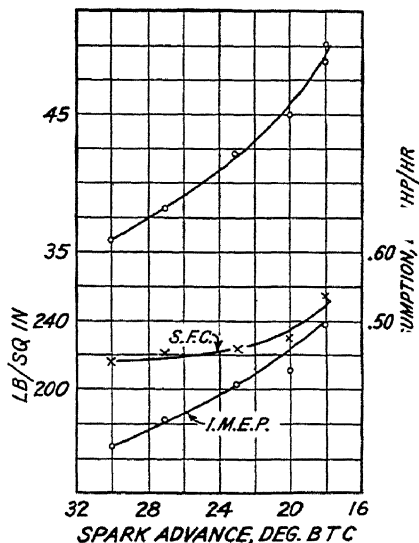

FIG. 41.—Effect of spark advance on maximum permissible inlet air pressure and on maximum permissible imep. Engine speed 2,500 rpm; iso-octane + tetraethyl lead; compression ratio, 8.0; inlet-air temperature, 200°F. (Rothrock and Biermann, N.A.C.A. Tech. Rept. 655, 1939.)

of the normal running time. The loss in power and the increase

in fuel consumption due to the retarded spark would be considerably less at cruising speeds because there the best power spark advance is less than that for take-off rpm.

Effect of RPM.—The effect of rpm on detonation is somewhat involved, for it depends partly on the fuel used.³ However, there seems to be a time factor involved in detonation. The fuel-air mixture must be exposed to critical pressures and temperatures for an appreciable time before detonation occurs. At higher engine speeds, the flame front may traverse the combustion chamber before detonation occurs so that the detonation limit is higher at higher rpm. The effects of rpm are closely associated

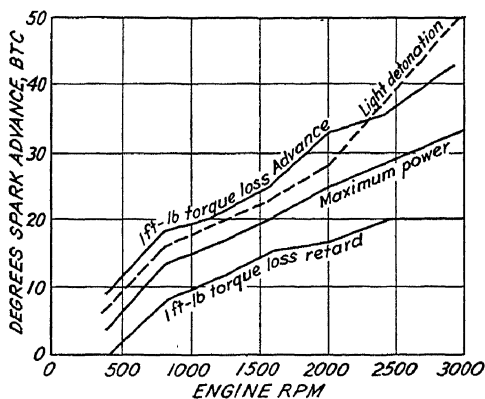

FIG. 42.—Spark advance for maximum power and for light detonation for a standard automobile engine. (*Fitzsimmons, S.A.E. Trans., vol. 50, 1942.*)

with those of spark advance, for the optimum spark advance for either best power or limiting detonation changes with engine speed in much the same way. Figure 42 shows the effect of rpm on the spark advance required for the maximum power and best fuel economy of an automobile engine. This type engine is always fitted with an automatic spark-advance device to take full advantage of the gains in power and fuel economy that can be achieved by using a greater spark advance at the higher rpm's. The load requirements for automobile engines vary widely at all speeds; hence, an automatic retard mechanism operating on the basis of manifold pressure is also necessary to prevent detonation at high manifold pressures and bmep's. Aircraft engines, however, always deliver their maximum torque at high speeds and, in the cruising-power range, operate at a considerably lower

rpm where the spark advance for maximum power is more nearly that of the fixed spark advance used.

Effect of Manifold Air Temperature.—Increasing the air temperature in the intake manifold raises the temperature of the last bit of charge to burn, making it more likely to detonate.

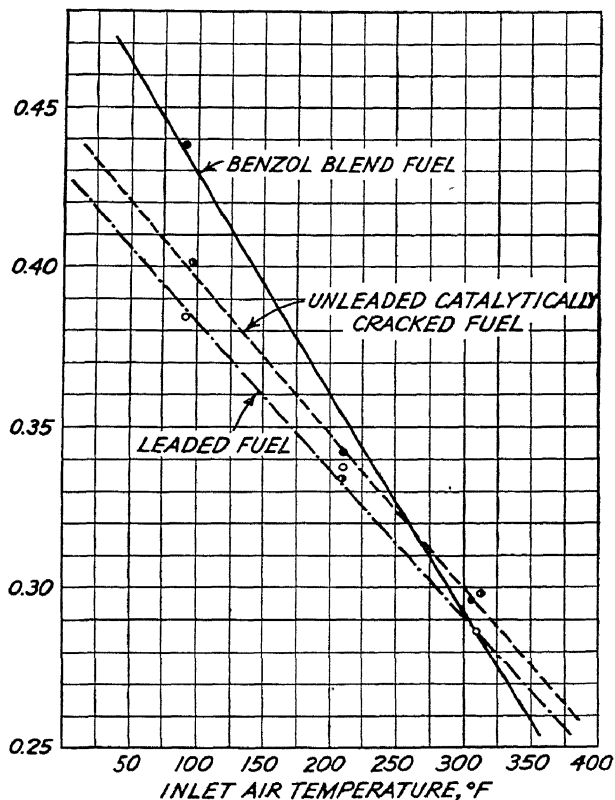

FIG. 43.—Effect of inlet air temperature on maximum permissible density factor for three fuels. Flat-disk cylinder head; engine speed, 1,200 rpm; fuel-air ratio, 0.0785; light detonation. (Daniel Guggenheim School of Aeronautics, New York University.)

Figure 43 shows the maximum permissible value of a factor directly proportional to the density of the last part of the charge to burn plotted against the inlet-air temperature for three different fuels. Note the greater temperature sensitivity of the fuel containing benzene.

Effect of Cylinder-head Temperature.—The temperature of the combustion-chamber walls also affects the temperature of the

last part of the charge to burn, though to a lesser extent than the manifold air temperature. Figure 44 shows the maximum permissible performance factor described above plotted against coolant temperature for the fuels shown in Fig. 43.

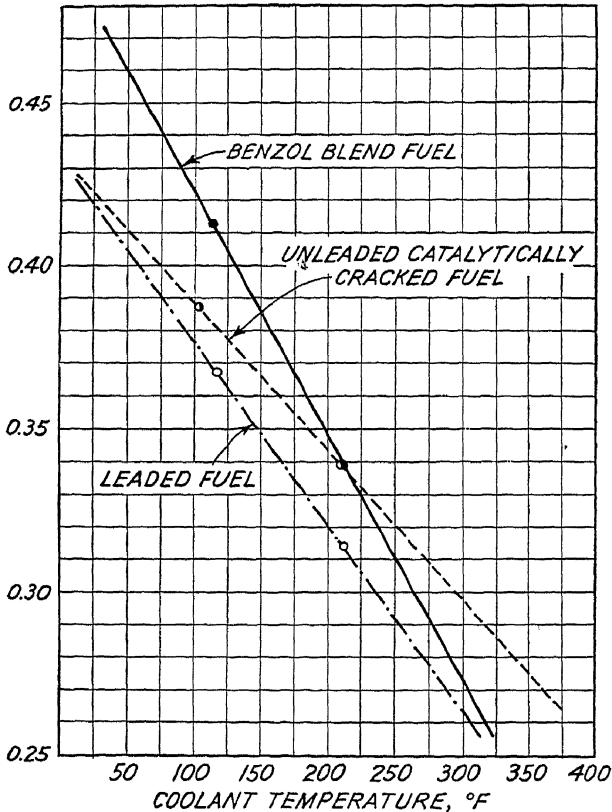

FIG. 44.—Effect of coolant temperature on maximum permissible density factor for three fuels. Flat-disk cylinder head; engine speed, 1,200 rpm; fuel-air ratio, 0.0785; light detonation. (Daniel Guggenheim School of Aeronautics, New York University.)

Effect of Fuel-Air Ratio.—Mixtures either richer or leaner than that for best power are less prone to detonate. Very rich mixtures are particularly effective in inhibiting detonation. Figure 45 shows the effect of specific fuel consumption on the maximum imep obtainable. In this case, specific fuel consumption is practically a linear function of fuel-air ratio.

Effect of Combustion-chamber Size.—As pointed out in connection with the effects of rpm, there seems to be a time factor

involved in detonation: if the entire charge is burned quickly, detonation is less likely to occur. Since the flame velocity is fixed at a particular rpm, the distance from the spark plug to the farthest part of the combustion chamber thus becomes an important consideration, for it determines the time element. In the early days of racing cars, the engines were made with pistons of small diameter, sometimes less than 2 in., to prevent detonation. In practice, it has been found necessary to limit the diameter of cylinders using but one spark plug to about 3 in. and those using two spark plugs to about 6 in., the latter being the largest

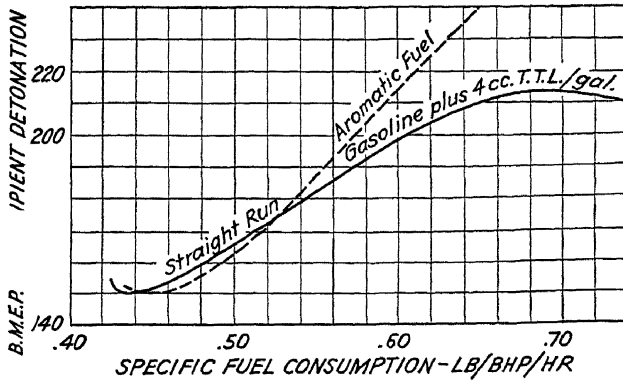

FIG. 45.—Characteristic curves showing maximum imep without detonation as a function of specific fuel consumption for two typical fuels.

cylinder diameter in general use in aircraft engines. Still larger cylinders would probably require three or four spark plugs. Combustion-chamber shape also has an effect, but the problem is complex. Most aircraft engines use combustion chambers that have characteristics similar to those of a spherical bomb.

Effect of Combustion-chamber Deposits.—Since hot spots are a factor affecting detonation, any deposits of carbon or of lead compounds that form on the piston or on the inner surface of the cylinder head are likely to increase the tendency of the engine to detonate by increasing the temperature of the charge. This effect is dependent on many variables. In general, it has been found that it is not large for high-power aircraft engines and that most of the change occurs during the first 50 hr of operation after an overhaul.

References

1. MARVIN, C. F., A. WHARTON, and C. H. ROEDER: Further Studies of Flame Movement and Pressure Development in an Engine Cylinder, *N.A.C.A. Tech. Rept.* 556, 1936.
2. ROTHROCK, A. M., and R. C. SPENCER: A Photographic Study of Combustion and Knock in a Spark Ignition Engine, *N.A.C.A. Tech. Rept.* 622, 1938.
3. ROTHROCK, A. M., and A. E. BIERMANN: The Knocking Characteristics of Fuels in Relation to Maximum Permissible Performance of Aircraft Engines, *N.A.C.A. Tech. Rept.* 655, 1939.

CHAPTER V

SUPERCHARGING

The supercharger has been one of the most important factors in the development of the aircraft engine. Since about 1933, a supercharger has been an integral part of all the larger engines, serving to improve fuel mixing and vaporization, sea-level power output, and, most important of all, the power available at

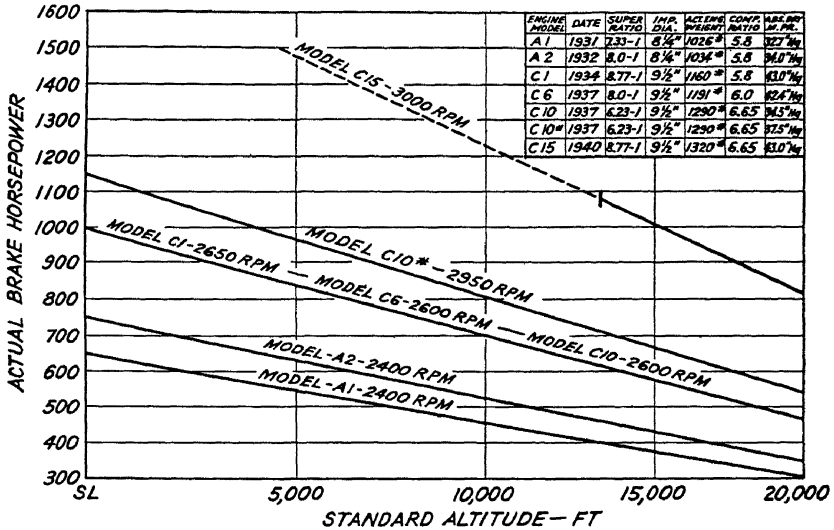

FIG. 46.—Altitude performance for successive models of Allison V-1710 engines, showing the important part played by the supercharger. (*Hazen, S.A.E. Trans., vol. 49, 1941.*)

altitude. Since the bmep and hence power output increase linearly with manifold pressure, supercharging has offered a convenient means for engine manufacturers to meet demands for higher performance engines without disrupting their production lines. By increasing the amount of supercharging, using a higher octane fuel to avoid detonation, and “beefing up” parts wherever necessary to permit the higher power outputs, it

has been possible to double, and in some cases to triple, the output of a particular series engine without increasing its piston displacement. All the engine manufacturers have followed this practice, at least in part, because of the many savings in production and servicing resulting from standardization of bore and stroke dimensions. Figure 46 shows curves of the maximum power available plotted against altitude for successive models of the Allison V-1710 engine. The right-hand column of the tabulated data gives the manifold pressure used in each case and shows that the greatest factor in the increase in power capacity was the increased manifold pressure delivered by the supercharger.

ENGINE REQUIREMENTS

Types of Superchargers.—A number of different types of air compressor have been used to increase the pressure in the intake manifold of internal-combustion engines. Many marine diesels have employed pistons reciprocating in scavenger cylinders as large as 25 ft in diameter to pump air into the smaller power cylinders. Axial-flow fans have a high efficiency, but the pressure rise per stage is small. *Roots blowers* have been used on aircraft engines and are being widely used on automotive, railroad, and marine diesels. Since they are of the positive-displacement type, they make possible high engine torque at low rpm. The centrifugal-type blower, however, is in almost universal use for aircraft engines because it is considerably lighter, more simple, and more compact than other compressors.

Fuel Mixing.—Rapid vaporization and mixing of the fuel have constituted one of the important problems in the development of all types of gasoline engine. Especially in the higher power engines, it is important that all cylinders receive the same weight of charge each revolution, and particularly that they receive the same fuel-air ratio. Any lack of symmetry in the induction system is likely to cause segregation of the fuel stream, giving some cylinders mixtures that are too rich while other cylinders receive a charge that is too lean. Such differences in charge weight and/or fuel-air ratio may cause serious differences in cylinder temperature and *rough*, or irregular, engine operation. Good fuel economy and smooth engine operation can be obtained only if all cylinders receive equal charges of well-mixed fuel and air, with the fuel either completely vaporized or so finely divided

that vaporization can be completed during the intake and compression strokes. Since the air velocities in the engine induction passages are about 100 fps, only a few hundredths of a second are available for this purpose. Most automobile engines and aircraft engines not fitted with superchargers employ a hot spot heated by exhaust gases, hot oil, or some such means to raise the temperature of the fuel-air mixture as an aid to fuel vaporization. A supercharger placed between the carburetor and the engine offers a much better solution to the problem. As a result, one of the most publicized advantages of the earlier superchargers was the improved fuel economy gained from the "atomization" of the fuel and the thorough fuel-air mixing accomplished in the high-velocity impeller.

Engine Performance.—To meet the requirement of light weight and yet permit high-power operation for short periods of time, it has been found best to build a relatively small engine and supercharge it enough to make it develop more than the necessary take-off power. Although this extra power capacity is of little value at sea level except for take-off or emergency work, it is essential to permit continued medium-power operation up to high altitudes. Most of the larger engines are now built with superchargers capable of giving intake manifold pressures at sea level which are considerably higher than that at which the engine may be safely operated. In such engines the throttle must not be fully opened until an altitude of 8,000 to 15,000 ft is reached, at which point the engine will still deliver its full rated power in spite of the much lower atmospheric air density.

Familiarity with the characteristics of the supercharger as an air pump is essential to an understanding of the limitations it imposes on the performance of supercharged engines. Some of these operating characteristics can be best approached on the basis of elementary fluid mechanics, while others follow directly from basic thermodynamic formulas.

SUPERCHARGER THEORY

Pressure Rise in the Impeller.—The amount of pressure that a supercharger can build up is primarily a problem in fluid mechanics. If a hollow disk or wheel filled with fluid is rotated rapidly, centrifugal force will set up a pressure differential in the fluid between the axis of rotation and the periphery of the wheel.

The value of this pressure increase can be obtained by integrating the force acting on each element of mass from the center of the wheel to the outer edge. Using the notation of Fig. 47, the force acting on each element of fluid is

$$dF = dm r\omega^2 = \rho tr d\theta dr r\omega^2$$

where ω is the angular velocity of the wheel in radians per second, and ρ the density of the fluid in slugs per cubic foot. The pressure increase between r and $r + dr$ equals this force divided by the area of the element, or

$$\frac{\rho tr d\theta dr r\omega^2}{tr d\theta} = \rho dr r\omega^2 \quad (2)$$

Integrating, the pressure differential from the center to the periphery becomes

$$= \int \rho r^2 \omega^2 dr = \frac{1}{2} \rho r^2 \omega^2 \quad (3)$$

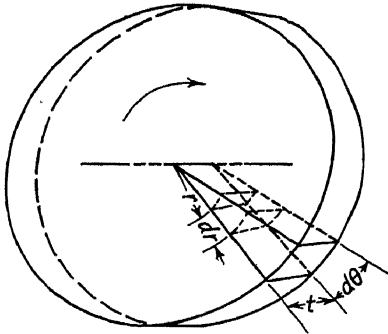

FIG. 47.—Diagram of a hollow wheel filled with fluid.

It is often more convenient to work with the peripheral speed of the wheel V in feet per second. Since

$$V =$$

then

In the actual supercharger the closed disk is replaced by an impeller like that in Fig. 21. Air flows axially into the center of the impeller and is accelerated circumferentially by the curved buckets at the inlet. As the air flows outward between the radial blades, it is further accelerated so that it leaves the tip of the wheel at a high tangential velocity. Therefore, in addition to the static-pressure rise through the impeller, there is a considerable amount of velocity energy imparted to the air. This velocity energy may be converted into a further increase in static pressure by slowing the air down with a minimum amount of eddy losses, etc. A diffuser such as that shown in Fig. 21 may be

used for this purpose, the spiral vanes guiding the air away from the tip of the impeller through expanding passages in which deceleration can be accompanied by a corresponding increase in static pressure. The ideal static-pressure increase would therefore be equal to the velocity pressure, *i.e.*,

$$\Delta P_2 = \frac{\rho V^2}{2} \quad (5)$$

The total pressure rise theoretically available through the supercharger thus becomes

$$\Delta P_1 + \Delta P_2 = \frac{\rho V^2}{2} + \frac{\rho V^2}{2} = \rho V^2 \quad (6)$$

It is evident from the above that half the static-pressure rise through the supercharger should occur in the impeller and half in the diffuser.

These derivations represent a first approximation to actual conditions. An incompressible fluid was assumed in the derivation so that the compressibility of air would introduce an error. Friction losses caused by shearing the air film around the impeller, leakage and backflow from the high-pressure region at the discharge through the clearance between the impeller and the casing, and eddy losses at the impeller inlet, the diffuser inlet, and the diffuser outlet tend to reduce the theoretically available pressure rise. Other similar factors also operate to reduce the actual pressure rise.

Power Input to Supercharger.—An over-all value for the power required to drive a supercharger can be gained from momentum considerations. Since the air stream enters the impeller axially with no rotational component, its rotational momentum going into the wheel is zero. Its rotational momentum leaving the wheel is given by the product of the mass flow per second and the tangential velocity, *i.e.*, the impeller tip speed. The reaction caused by this change in momentum is a force equal and opposite to it, and thus gives the torque opposing rotation of the wheel. Therefore, the power input is

$$\begin{aligned} \text{hp} &= \frac{1}{550} \cdot (\text{momentum})(\text{tip speed}) \\ &= \frac{1}{550} \frac{W}{g} V^2 \end{aligned} \quad (7)$$

where W is the weight flow of air in pounds per second.

Temperature Rise.—Regardless of the means used to compress air, certain thermodynamic relations hold, and the supercharger may be regarded as an air compressor of any sort rather than as a problem in fluid flow. Since the walls of the supercharger housing are at a temperature about equal to that of the air, little or no heat is added to or taken from the air. Any fluid frictional losses, however, will appear in the form of heat, which will increase the temperature of the air leaving the supercharger.

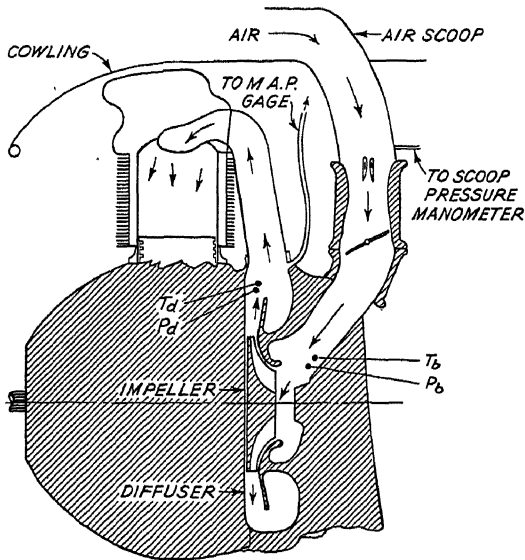

FIG. 48.—Longitudinal section through the supercharger and the induction passages of a radial engine.

Neglecting these effects for the moment, consider what should happen to the temperature of the air being compressed by the impeller. On the assumption that the air is compressed adiabatically, the temperature increases with the pressure, the relation being

$$T_d = T_b \left(\frac{P_d}{P_b} \right)^{\frac{\gamma}{\gamma-1}}$$

Using the notation given in Fig. 48 and substituting 1.4 for γ , this becomes

This is an important relation and is frequently used in supercharger work.

Power Required for Adiabatic Compression.—The power required for the adiabatic compression of a gas may be found from a number of commonly used thermodynamic formulas. Since the inlet air temperature and pressure are ordinarily given and the power input for a particular delivery pressure desired, the power input for adiabatic compression is most conveniently found from

(9)

where R is the gas constant, W is the weight of air flowing in pounds per second, and the other symbols are as before.

SUPERCHARGER PERFORMANCE CHARACTERISTICS

Pressure Ratio.—The performance of an actual supercharger differs somewhat from that of the idealized compressor. Several parameters and coefficients are used to describe the characteristics of the actual unit. From the analysis above, it is evident that the ratio of the outlet to the inlet pressure is one of the most important parameters. This *pressure ratio* was shown to be dependent mainly on the impeller tip speed and, to a lesser extent, on the inlet air temperature.

Pressure Coefficient.—One indication of the efficiency of the supercharger is the ratio of the power theoretically required for adiabatic compression to that actually required, both being based on the actual pressure rise through the supercharger. This ratio is called the *pressure coefficient*, η . It has been found that the power input to the fluid as previously derived from momentum considerations gives the actual power input to the wheel accurately if the friction in the impeller shaft and drive mechanism is neglected. This is especially convenient because the bearing and gear frictional losses are ordinarily difficult to measure without elaborate provisions. The pressure coefficient thus becomes

Upon substituting the values of γ and R for air, this reduces to

$$\eta = \frac{(P_d/P_b)^{0.283} - 1}{V^2/6,088T_b} \quad (10)$$

This can be rearranged to give the pressure ratio P_d/P_b explicitly in terms of the tip speed, the pressure coefficient, and the inlet temperature

$$\left(\frac{P_d}{P_b}\right)^{0.283} - 1 = \frac{V^2 \eta}{6,088T_b} \quad (11)$$

or

$$= \left(\frac{V^2 \eta}{6,088T_b} + 1\right)^{3.53} \quad (12)$$

Temperature Coefficient.—Air compression in the supercharger is accompanied by both an adiabatic-temperature rise and a temperature rise due to fluid friction and turbulence. As a matter of fact, all the fluid frictional losses go directly into heating the air flowing through the supercharger so that the temperature rise is largely dependent on fluid friction and turbulence losses. It is desirable to keep the temperature rise to a minimum both to obtain the maximum intake manifold air density and, even more important, to prevent detonation. Figure 43 shows how rapidly the maximum allowable intake manifold pressure as limited by detonation falls off with an increase in intake manifold temperature, clearly indicating the advantage of a low temperature rise. The *temperature coefficient*, also called the *temperature-rise ratio*, is used as a measure of the efficiency of a supercharger from the standpoint of the temperature rise. It is taken as simply the ratio of the adiabatic-temperature rise to the actual-temperature rise, *i.e.*,

$$\phi = \frac{T_b [(P_d/P_b)^{0.283} - 1]}{T_d - T_b} \quad (13)$$

The quantity within the brackets, *i.e.*, 1 less than the pressure ratio raised to the 0.283 power, is an important parameter and is designated by the symbol Y . That is,

$$\left(\frac{P_d}{P_b}\right)^{0.283} - 1 \quad (14)$$

Density Coefficient.—A third coefficient, which combines the effects of changes in both temperature and pressure, is used in

connection with engine performance calculations. The density coefficient θ may be defined as the ratio of the actual density ratio to that for ideal adiabatic compression. That is,

$$\theta$$

where δ_d and δ_b are the air densities at the diffuser outlet and the impeller inlet, respectively.

But

$$\left(\frac{\delta_d}{\delta_b}\right)_{\text{adiabatic}} = \overline{P_b T_d} / \overline{P_a T_a} \text{ adiabatic} \tag{16}$$

Making use of Eqs. (8) and (12), letting $\eta = 1$, substituting them in Eq. (16), and substituting Eq. (16) in the numerator of (15),

$$\left(\frac{V^2}{6,088 T_b} + 1\right)^{2.53} \tag{17}$$

Load Coefficient.—Perhaps the most important parameter in supercharger work is the volume of air passing through the super-

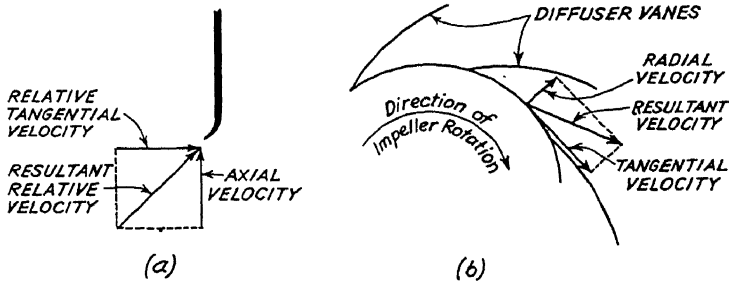

FIG. 49.—Vector diagram showing relative-velocity components for the air stream passing through a supercharger.

charger per revolution of the impeller. This is referred to as Q/n and is expressed in cubic feet per revolution of the impeller. It has been found that supercharger characteristics are well defined by this number. Variation in impeller speed up to a tip speed about that of sound has little effect on the supercharger characteristics if the value of Q/n is kept constant. The reason for this may be seen from the effect of Q/n on the air flow into the impeller and from the impeller into the diffuser. Figure 49

shows a vector diagram of the relative velocity of the entering air stream and the impeller. Either an increase or a decrease in the inlet air velocity would result in a change in the angle of approach of the air entering the impeller, causing turbulence in the air system and a loss in efficiency. The bucket angle is designed for a particular set of impeller and inlet air velocities, *i.e.*, a constant inlet air flow in cubic feet per revolution. Similarly, the diffuser vanes are designed to have the same angle as the air flow leaving the impeller. A change in Q/n from the

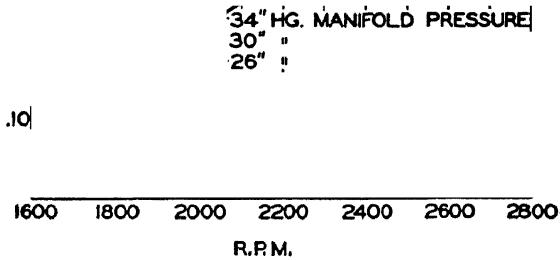

FIG. 50.—Effect of speed and manifold pressure on the load coefficient Q/n for a typical supercharged engine. (*Buck, I.A.S. Jour., vol. 7, No. 8, June, 1940.*)

design condition will result in a change in air-flow conditions and a change in efficiency.

Fortunately, the load coefficient Q/n remains fairly constant throughout the engine operating range. It will be shown in the next chapter that the full-throttle air flow of an engine with a gear-driven supercharger is almost directly proportional to the rpm, falling off only a little at the higher speeds. As an engine is throttled at a constant rpm, the volume of air flowing still remains essentially constant. This is due to the fact that the volume of air drawn into the cylinders each revolution depends primarily on the piston displacement. Since the supercharger pressure ratio remains constant, the ratio of the volume of air leaving the supercharger to that entering the impeller must also remain constant. Thus the volume of air flowing into the impel-

ler at a constant rpm is practically independent of the throttle opening. Figure 50 shows the effect of both rpm and manifold pressure, *i.e.*, throttle opening, on Q/n as determined from test data for a widely used engine.

Effect of Q/n on Efficiency.—Any change in Q/n from that giving smooth air flow into the impeller and diffuser inlets causes turbulence which results in both a pressure loss and a temperature increase and gives lower values for both the pressure and the temperature coefficients. Figure 51 shows curves obtained for

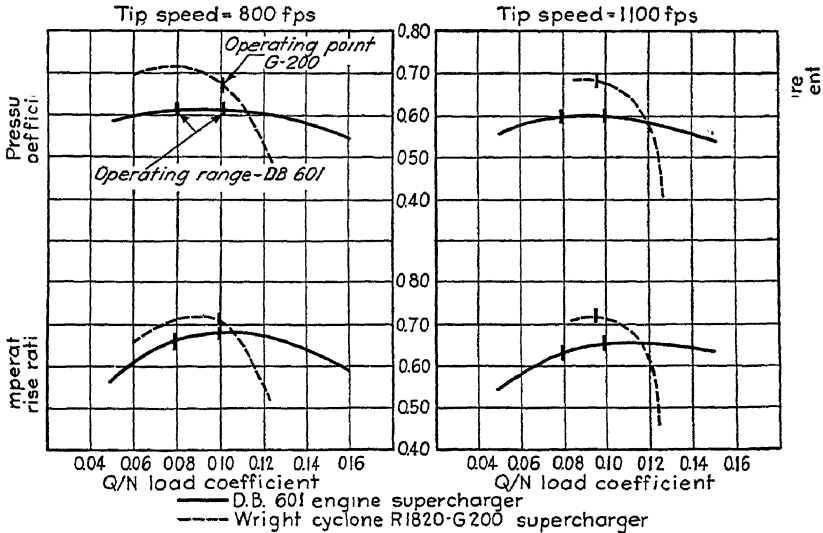

FIG. 51.—Characteristics of DB-601A engine supercharger and Wright Cyclone engine supercharger at impeller tip speeds of 800 and 1,100 fps. (Young, S.A.E. Trans., vol. 49, 1941.)

two superchargers. Note that they both display this characteristic. The German DB-601A supercharger was fitted with a vaneless diffuser, while that for the Wright Cyclone, following American practice, used a conventional vane-type diffuser. The former gives lower maximum efficiencies but a much flatter curve by preventing turbulence losses at the diffuser-vane inlets that would accompany changes in Q/n from the optimum value. Note that the curves for both the pressure and the temperature coefficient are similar, as one would expect from theoretical considerations.

Effect of Impeller Tip Speed.—As the impeller tip speed approaches the velocity of sound, compressibility effects begin

to cause a loss in efficiency. Fortunately, the velocity of sound increases linearly with temperature so that the temperature rise through the impeller increases the allowable tip speed considerably above that for air at standard conditions. Figure 51a when compared with Fig. 51b shows that increasing the impeller tip speed from 800 to 1,100 fps caused all the curves to be displaced downward. Most of this loss in efficiency probably occurred above a tip speed of 1,000 fps. Curves run at tip speeds below 800 fps would probably be similar to that for 800 fps. Supercharger efficiency falls off so rapidly above tip speeds of 1,200 fps owing to compressibility effects that higher speeds are seldom used.

The pressure ratio obtainable in a single stage, *i.e.*, with one supercharger impeller, is definitely limited to about 3:1. This is due partly to the limiting effects of tip speed and partly to the difficulty involved in providing an impeller eye of sufficient diameter to handle the large volume of low-density air at the inlet. Thus the high pressure ratios required for altitudes above about 25,000 ft can be obtained only through the use of two or more stages. This may be accomplished with an auxiliary stage. From the auxiliary stage, air is delivered under pressure to the carburetor. The air can then flow from the carburetor through the main stage in the engine as in conventional single-stage units.

Surging.—An important and peculiar characteristic of the centrifugal compressor can be deduced from the curves in Fig. 51. Note that the pressure coefficient falls off at values of Q/n less than that for the maximum value of the coefficient. In actual operation, this may lead to serious trouble; for if the pressure coefficient falls off, the flow through the supercharger is reduced, giving a still smaller pressure coefficient, etc. The result is that the flow drops to zero. This, of course, is not a stable condition, and a surge of air suddenly flows through the supercharger again. As conditions begin to stabilize, the flow falls off once more until it drops to a value less than that for the maximum pressure coefficient and the process is repeated. When this occurs in the actual supercharger, the complete cycle usually requires only a fraction of a second. The flow fluctuates rapidly from very high to very low values, and back again. This is called *surging*. When the supercharger is incorporated in the induction system of an engine, surging conditions in the supercharger may cause violent fluctuations in engine power output, making engine operation in the surging range out of the question. The result

is that gear-driven superchargers incorporated in the engine must be designed so that operation is always at values of Q/n which are greater than that for maximum efficiency.

This becomes especially important in the case of engines equipped with two-speed superchargers, for the larger value of n in the higher gear ratio gives a lower value of Q/n for a given set of conditions owing to considerably greater frictional losses in the air flow through the induction system. This makes it necessary to place the operating point for the lower gear ratio considerably to the right of the peak of the pressure- and temperature-coefficient curves, thus penalizing engine performance at low altitudes. The operating range of Q/n indicated on the curves for the DB-601A supercharger covers both low and high gear ratios. The operating point indicated for the Wright Cyclone is for the high-blower gear ratio. That for low blower would be displaced to the right a distance about equal to the width of the operating range of the DB-601A supercharger.

If two engine-driven stages are used to improve engine performance at high altitudes, the carburetor and throttle are normally located between the two stages. If surging is to be prevented in the auxiliary, or first, stage, the carburetor throttle must be wide open. If it is not and the auxiliary stage is operated, the volume of air flowing through it will be much less than the design value, giving a low Q/n and probably surging.

Figure 52 shows curves that indicate something of the way in which supercharger performance affects engine altitude performance. They are based on supercharger pressure and

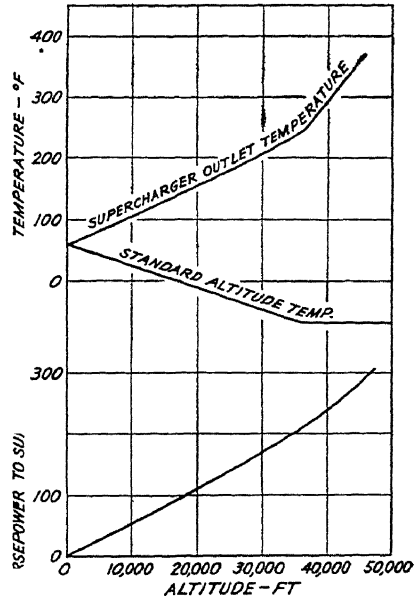

FIG. 52.—Horsepower input and air-outlet temperature for a hypothetical variable-speed auxiliary-stage supercharger designed to maintain 29.92 in. Hg pressure at the supercharger outlet and a constant-weight air flow equal to that required by an engine developing 1,200 bhp at sea level. Constant pressure and temperature coefficients of 0.65 were assumed.

temperature coefficients of 0.65 and on standard altitude conditions. The temperature rise through the supercharger, the necessary pressure ratio, and the power required to supply air at a pressure of 29.92 in. Hg at the carburetor inlet are given for an engine developing 1,200 hp.

IMPELLER STRENGTH

Normal Operating Stresses.—The mechanical strength of the supercharger impeller is an important consideration. Rotating as it does at as much as 25,000 rpm, the centrifugal force acting on the blades sets up considerable stresses. Further, the air forces are appreciable, while the interference effects of the impeller blades passing the diffuser vanes serve to set up vibrations that make the fatigue strength of the material the limiting consideration. The gear teeth in the gear train driving the impeller and engine crankshaft torsional vibration also tend to excite impeller vibration. The combined air and inertia loading accompanying rapid acceleration may also set up severe stresses. Many supercharged engines have been built with a friction clutch between the crankshaft and impeller so that slippage may occur there to relieve the loads on the impeller blades during acceleration. Most of the later engines have no such devices.

It is possible to make a complete stress analysis of the impeller. In one case on record, such an analysis was made and the bursting speed predicted. When tested, the actual impeller failed within 100 rpm of the predicted speed. That speed, of course, was well above the operating range.

Effect of Foreign Material.—When superchargers first came into use, some concern was felt over what might happen if ice forming in the carburetor were to break off and fall into the impeller. A simple but convincing test was tried—ice cubes from a household refrigerator were tossed into the carburetor air scoop to demonstrate the durability of the impeller. The test was made and showed that the ice caused no ill effects. Other harder material will damage an impeller, however. More than one engine has been sabotaged by a nut tossed into the carburetor adapter before the carburetor with its air screen had been installed.

Reference

1. БУСК, R. S.: Mechanically Driven Superchargers, *I.A.S. Jour.*, vol. 7, No. 8, June, 1940.

CHAPTER VI

PERFORMANCE

The performance of any airplane is directly dependent on that of its engine. The take-off run, the rate of climb, the service ceiling, the cruising speed, and especially the cruising range are all a function of the performance characteristics of the engine. It is therefore necessary for the engine manufacturer to supply the airplane designer with complete information on the power capacity of the engine at all altitudes and on its fuel-consumption characteristics at any point in the operating range. Since no equipment is ordinarily provided for measuring engine power output during routine flight work, it is also necessary that the airplane operator be supplied with charts from which he can determine the power being delivered by the engine under any conditions of operation. The engine manufacturer also supplies charts indicating the optimum engine powers and speeds for minimum specific fuel consumption.

The problem of engine performance might be divided into the five following parts: (1) the determination of the maximum power the engine will deliver under all conditions; (2) the preparation of charts giving engine power output in terms of two easily measured parameters, *viz.*, rpm and manifold pressure; (3) the effect of various supercharger arrangements on engine altitude performance; (4) the correction of the data under (1) and (2) to standard conditions; (5) the determination and presentation of the minimum-specific-fuel-consumption characteristics of the engine.

LIMITATIONS ON ENGINE POWER OUTPUT

Power Capacity and Engine Air Consumption.—What might be called the *power capacity* of an engine is one of its most important characteristics. Since we are dealing with a heat engine, the power it will deliver is proportional to the heat liberated in the combustion chamber. This, in turn, is proportional to the

weight of the charge delivered to the cylinders—any change in the weight of that charge results in a like change in horsepower.

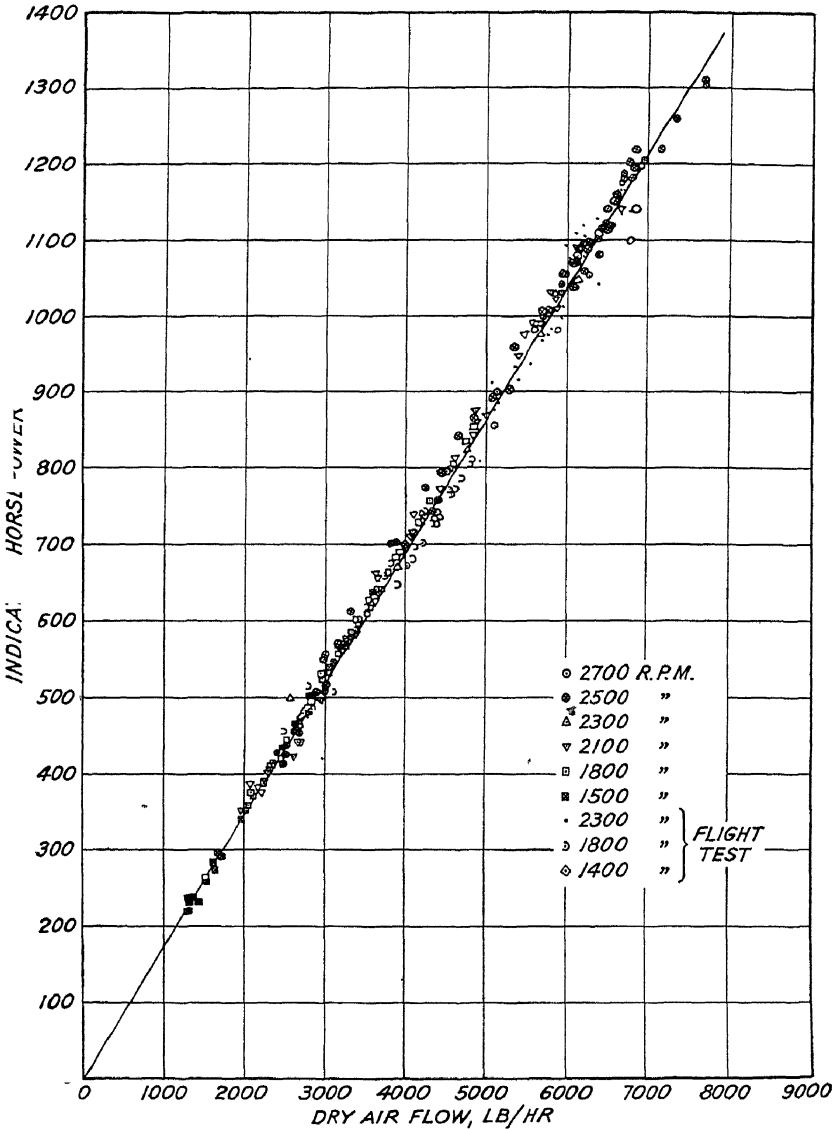

FIG. 53.—Relation between indicated horsepower and air flow into the engine induction system. (*Hersey, I.A.S. Jour., vol. 9, No. 10, August, 1942.*)

Figure 53 shows a plot of a large number of experimental points, clearly showing that, at a constant fuel-air ratio, *engine air flow*

is directly proportional to the indicated horsepower. This relationship is extremely important, for it shows that anything which changes the amount of air flowing into the engine will cause a corresponding change in the engine indicated-horsepower output. Thus an engine can be looked upon as an air pump—the greater the amount of air it can handle per unit of time, the greater the amount of power it is able to deliver.

RPM and Power Capacity.—From the above, one would expect that anything limiting engine air flow would limit the power output. One of the most important factors is engine speed, or rpm. An increase in rpm will cause an increase in the volume of air displaced by the pistons per unit of time and thus will increase the power output. The speed at which an engine may be operated is limited by the loads which the connecting-rod bearings will support. Since these bearing loads increase as the square of the speed, they impose a definite limitation on the rpm at which an engine may be safely operated. .

Another factor that may limit rpm is inherent in poppet valve mechanisms. Acceleration forces become so great at the higher speeds that the valve springs cannot force the tappets to follow the cam, and the valves begin to *float*. This will permit flame from the combustion chamber to ignite the charge in the intake manifold and will cause severe backfiring.

The Induction System and Power Capacity.—At a constant engine speed, the weight of air flowing to the cylinders can be increased by opening the throttle until it is wide open. At full throttle, the engine air flow and hence the power output are limited by the flow resistance of the induction system. This resistance is small except at the higher speeds, where the pressure drop through the intake port in particular may become quite large. Thus the flow at full throttle and at the maximum safe rpm is limited by restrictions in the induction system. Therefore, one of the most important factors limiting engine power capacity is the air-flow capacity of the induction system and the intake valve port.

Supercharging and Power Capacity.—Supercharging is primarily intended to increase the weight of air flowing into an engine by increasing the air density in the intake manifold. It may be used to some extent to force air through the restrictions in the induction system. However, the induction passages are

generally made larger if they constitute an appreciable restriction, for the power losses due to friction in the air stream would otherwise be large. In any case, the power capacity of an engine may be increased by increasing the amount of supercharge.

Power Output Limitations.—To avoid damaging the engine, actual power output is usually limited to a value considerably less than the power capacity. Perhaps the most important of the factors limiting power output is detonation. Its destructive effects have already been discussed, as have the effects of intake manifold pressure and temperature on the tendency toward detonation. The smaller and medium-sized engines are designed to permit full-throttle operation without detonation, but the larger engines generally may not be operated with their throttles wide open at sea level. This limitation will be discussed in detail later in the chapter.

Operating conditions such as engine cooling and the mechanical strength of parts often limit power output. If cylinder-barrel cooling is inadequate, for example, lubrication will fail and the parts concerned will be irreparably damaged. In some engines the power must be limited because the parts are simply not strong enough to withstand more than a certain power output. Crankshaft vibration above certain speeds or powers may also limit the power output.

Propeller Limitations on Power Output.—The power-absorption characteristics of a fixed-pitch propeller largely determine the amount of power that may be obtained from engines equipped with this type of propeller. Although other factors have their effects and will be considered in Chap. XXV, the most important characteristic of a fixed-pitch propeller is that the power which it absorbs varies very nearly as the cube of the rpm. This is due to the fact that the air forces acting on the blades and hence the torque input necessary vary as the square of the rpm. Since the power absorbed is proportional to the product of the torque input and the rpm., the power required to drive a fixed-pitch propeller is proportional to the cube of the rpm. This relation gives us one of the most important types of curve used in engine operation and test work. An engine equipped with a fixed-pitch propeller must always operate on a *propeller-load curve*; *i.e.*, as the throttle is opened, the power increases as the cube of the rpm. The power may be increased until either full-throttle

or rated engine rpm is reached, depending on which occurs first.

Full-throttle and Propeller-load Performance.—The performance characteristics of engines delivering up to 200 or 300 hp can be represented fairly well by a set of curves such as that shown in Fig. 54. These curves are for an unsupercharged engine rated at 175 hp at 2,450 rpm. Two curves of horsepower are given,

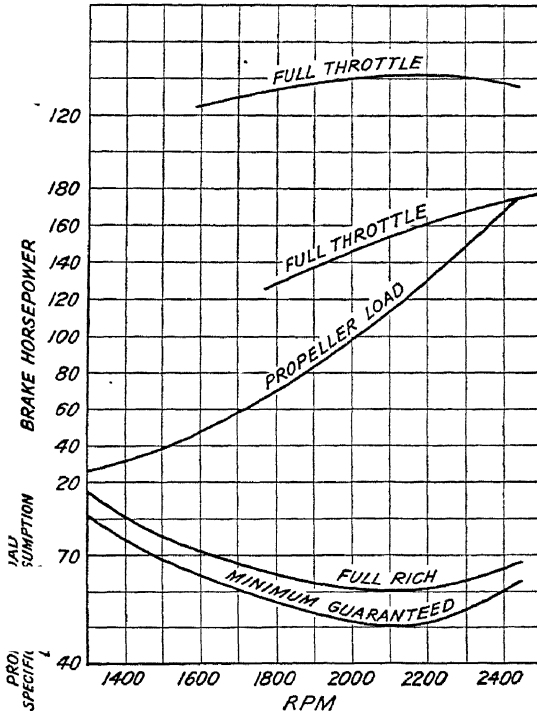

FIG. 54.—Sea-level performance curves for a Ranger 6-440C-2 engine. (*Ranger Aircraft Engines.*)

one for the power available at full throttle and the other for the power absorbed by a propeller designed to require 175 hp at 2,450 rpm. The latter curve would be spoken of as a *propeller-load curve through rated power*. Note that, if a larger propeller had been used, the power absorbed at any given rpm would have increased. The propeller-load curve would have been displaced to the left so that it would have intersected the full-throttle curve below 2,450 rpm. This would have made it impossible for the engine to deliver its full rated power.

It will be observed that the specific fuel consumption is a minimum in the cruising-power range, *i.e.*, at about 110 hp. Richer mixtures must be used at higher powers both to reduce the amount of cooling air required and to inhibit detonation. The frictional losses at speeds below 1,800 rpm on this propeller-load curve become a relatively large fraction of the power developed in the cylinders. A higher brake specific fuel consumption results.

A similar set of curves may be drawn to give the full-throttle and propeller-load horsepowers for a supercharged aircraft engine. The principal difference between the supercharged and the unsupercharged engine is that the full throttle bmep, instead of remaining practically constant as for the unsupercharged engine, tends to increase with crankshaft speed. This is due to the fact that the supercharger is geared directly to the crankshaft. The higher the speed of the crankshaft and hence of the supercharger impeller, the greater the pressure rise through the supercharger and the greater the full-throttle manifold pressure. This makes the full-throttle horsepower increase very rapidly. However, as in the unsupercharged engine, a point of diminishing returns is reached beyond which an increase in speed results in a loss in full-throttle bmep. Supercharged aircraft engines are usually given their take-off rating at a speed considerably below that for the maximum full-throttle bmep.

ENGINE PERFORMANCE CHARTS

Operating Requirements.—The fixed-pitch propeller automatically limits the engine rpm and absorbs nearly the proper horsepower so that power control for engines fitted with such propellers is not much of a problem. Variable-pitch propellers, however, may operate over a wide range of powers at any particular rpm. Thus, operation of larger airplanes equipped with engines delivering more than 300 hp and equipped with variable-pitch propellers has made necessary a more complete set of curves than those given in Fig. 54. Close control of both engine power and fuel consumption are needed, but the power must first be accurately determined before it can be controlled.

Relation between Power and Manifold Pressure.—The close relation between engine air flow and power output shown in

Fig. 53 suggests one method of determining power output. If an engine is run at a constant speed and fuel-air ratio, the indicated horsepower will be directly proportional to the weight of air flowing into the cylinders. This, in turn, will be directly proportional to the density of the air in the intake manifold. The effects of temperature on charge density are usually comparatively small because the range of temperature variation at a constant rpm is not large. It is possible to take these small variations into consideration by a correction that will be discussed later. Since the engine is controlled by throttling, the intake manifold air pressure may vary from 10 in. Hg abs. to

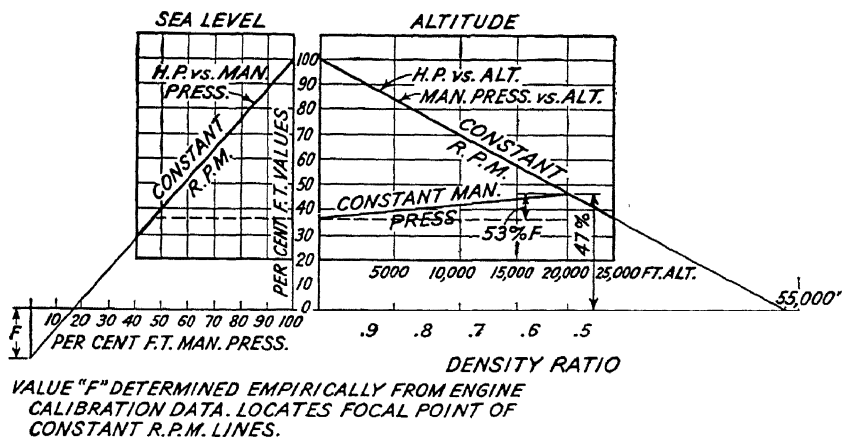

Fig. 55.-Basic elements of an engine performance chart. (Pierce, S.A.E. Trans., vol. 35, 1940.)

60 in. Hg abs., depending on the amount of supercharge. The intake manifold air density at various throttle openings would be proportional to the pressure. Therefore, the engine power output at a particular speed with a constant carburetor air inlet temperature should be directly proportional to the intake manifold air pressure. This has been found to be very nearly the case and provides a basis for power determination in flight. The left side of Fig. 55 shows the conventional method of plotting such a curve of power against intake manifold absolute pressure (map). This shows the first of several fairly simple linear relationships that make possible the preparation of charts defining the power output of an engine for any speed and manifold pressure in the operating range. By making use of these relationships, it is

necessary to run only a few dozen calibration points to define a complete set of curves for a given engine model.

Effect of RPM.—As the rpm is increased at full throttle, the engine power output increases. Thus one would expect that a series of manifold-pressure curves run at different speeds would lie one above the other with the full-throttle point at the right end falling at continuously higher manifold pressures owing to the increased pressure rise through the supercharger. A large amount of experimental data indicates that these straight lines are not parallel but intersect at a point of zero manifold pressure and a particular minus horsepower value which is characteristic of the engine. The left-hand portion of Fig. 56 shows a typical sea-level performance chart for a supercharged engine. The lower parts of the manifold-pressure curves are not given because they fall below the normal engine operating range.

Effect of Altitude on Power Capacity.—Both the air pressure and the air temperature decrease with increase in altitude. Obviously, the conditions that prevail at any given altitude vary somewhat with the weather, but the higher one goes the more nearly constant they become. Extensive investigations have been conducted on air conditions at altitude, and a set of standard pressures and temperatures has been established. The standard density at altitude is often given in terms of altitude-density ratio, *i.e.*, the ratio of the air density at standard altitude conditions to standard sea-level air density.

The net effect of altitude on power capacity should be proportional to intake manifold density. In a particular engine model, this, in turn, depends entirely on the density of the air at the carburetor inlet. It has been found after many different types of test work that the *engine power capacity at a constant rpm varies linearly with altitude-density ratio.*¹ Extrapolation of curves drawn through available data indicates that it drops to zero at an altitude-density ratio of approximately 0.117, *i.e.*, at an altitude of 55,400 ft. One might explain this roughly on the basis that at this point all the power developed in the cylinders is used to overcome engine friction and to drive the supercharger. This relation holds within the limits of experimental error for all types of engine regardless of combustion-chamber form, cylinder arrangement, compression ratio, or supercharger gear ratio.

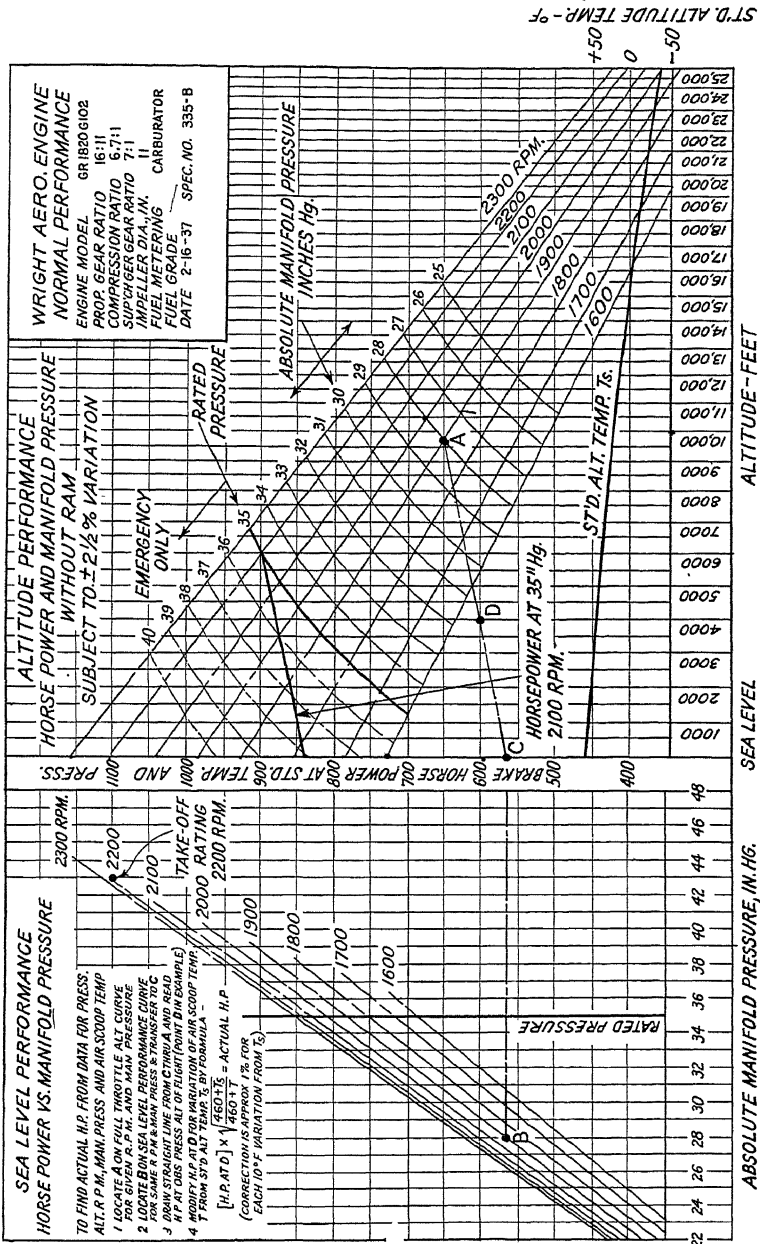

Fig. 56.—Performance chart for a supercharged aircraft engine widely used by commercial airlines. (Wright Aeronautical Corp.)

Figure 57 shows the full-throttle power output at constant rpm for a number of engines. In all cases, straight lines are drawn to pass through a point of zero power at 55,400 ft. Note

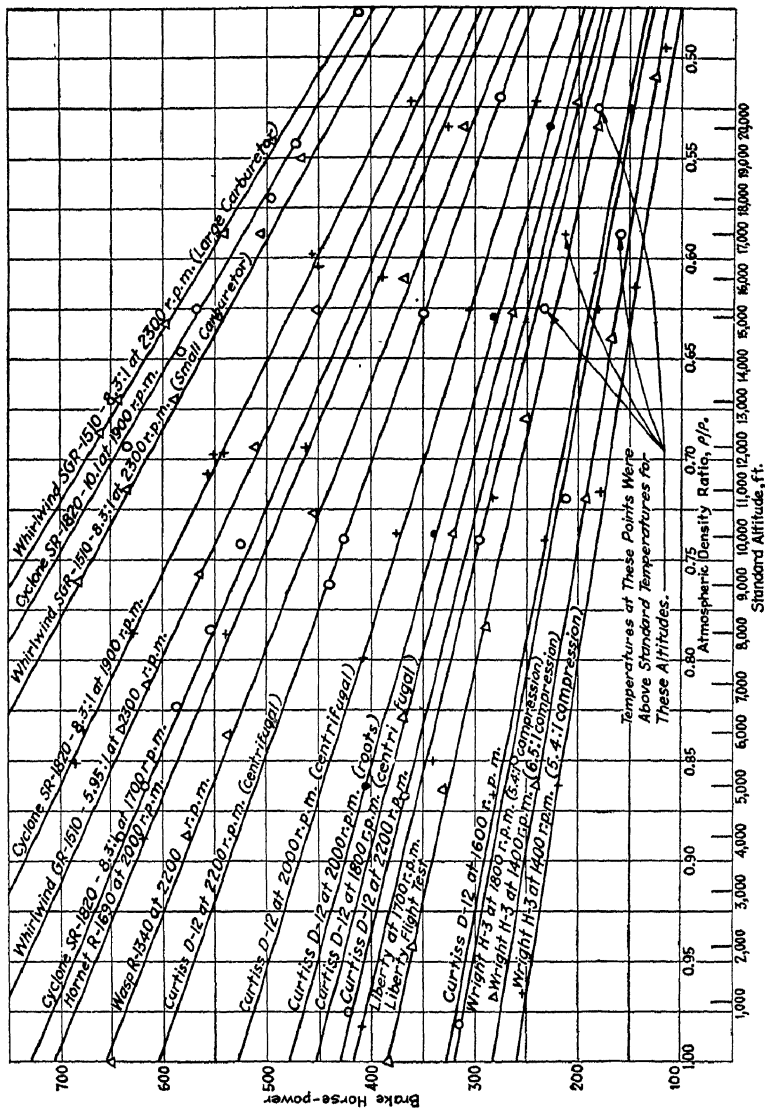

Fig. 57.—Plot of published data for the altitude performance of 12 aircraft engines. All lines drawn on the basis indicated in Fig. 55. (Gugg and Farrar, S.A.E. Trans., vol 29, 1934.)

how closely all points fall to their respective straight lines. Note, too, that a nonlinear scale of altitude in feet is used as well as a linear scale of altitude-density ratio. The former is more

convenient. Both scales might be used on the same chart if desired.

The Engine Performance Chart.—It has been shown that these basic relationships may be combined to define completely engine power output at any rpm, manifold pressure, and altitude.² Figure 55 shows the elements of such a chart, giving lines for only one rpm. Since only the upper portions of the chart are needed for normal operation, the portion outside the heavy black line is usually omitted in the finished chart.

This chart shows another feature that helps greatly in the construction and use of engine performance charts. It has been found that the constant-speed-constant-manifold-pressure lines all have a common slope which can be obtained from the negative horsepower value F on the left-hand side of the chart. The power increase from sea level to 20,000 ft is equal to about 50 per cent of F regardless of manifold pressure or rpm.

All the lines in Fig. 55 are for constant-rpm operation. A similar set may be drawn for any particular rpm. This will give networks of straight lines on both the sea-level and the altitude coordinates. The greater the rpm, the higher will be the full-throttle sea-level horsepower. Figure 56 shows a typical engine performance chart. Note that the constant rpm lines fall more and more closely together as one goes to higher speeds. This is due to the increasing effect of frictional losses both at the bearing surfaces and in the induction system.

A set of curved lines drawn through points of constant full-throttle manifold pressure is given on the altitude portion of the chart. These give one method for the determination of engine power output at part throttle under altitude conditions. Given the rpm, manifold pressure, and altitude, the engine power output can be determined. First the sea-level horsepower given by that manifold pressure and rpm should be obtained from the left-hand chart and transferred to the sea-level line at the left of the altitude chart. Then a line may be drawn to the right from that point to the full-throttle point having the same rpm and manifold pressure. The intersection of this line with that for the given altitude will indicate the horsepower output. The detailed instructions on the chart will show this method more clearly. The student should familiarize himself with this type of chart, for it is widely used.

MAXIMUM PERFORMANCE OF SUPERCHARGED ENGINES

The loss of engine power capacity with increase in altitude has presented a difficult problem, especially in military aircraft, for in military operations the airplane that has the best performance at the highest altitude has a tremendous advantage.

Single-stage Single-speed Geared Superchargers.—One way to improve the altitude performance of an engine is to supercharge it. This is most often done by introducing a gear-driven supercharger in the engine induction system between the carburetor and the cylinders. The term "gear-driven" means that the supercharger is driven by the crankshaft through a gear train. Supercharging the engine in this manner raises the full-throttle constant-rpm lines on the altitude chart. Although most engines are already supercharged, still greater power can be made available at altitude by increasing the amount of supercharge and thus further raising the full-throttle constant-speed lines. Since the pressure rise through the supercharger is proportional to the square of the impeller tip speed, the amount of supercharge may be increased by using either a larger diameter impeller or a higher gear ratio between the crankshaft and the impeller shaft. Figure 58 shows the effect on the rated-rpm curves of the performance specification chart of an increase in the blower gear ratio from eight to eleven times crankshaft speed. Note that the horsepower of the engine at a given map is somewhat less with the higher blower ratio because of frictional losses and reduced charge density due to higher intake manifold temperatures, but that the full-throttle manifold pressure available is much greater. As a result, the full-throttle power that may be obtained is greater at a given rpm and altitude.

The power output that can actually be used if a higher supercharge is employed is another matter. The losses accompanying an increase in the supercharger gear ratio are chargeable to the greater power input to the impeller and to the higher temperature of the air delivered to the intake manifold. The latter has two effects—it causes the density and hence the weight of the charge delivered to the cylinders each cycle to be somewhat less than would otherwise have been the case, and it makes detonation more likely. Detonation can be avoided by supplying the engine with a higher octane fuel or by limiting the mani-

fold pressure at which the engine may be operated. If a better fuel is not available, the engine must not be operated at full throttle at low altitudes. Thus the power at which an engine may be run at low altitudes will be decreased if the amount of supercharge is increased beyond a certain point because engine operation would otherwise be unsafe. The same fuel was used for operation with both blower gear ratios for the engine in Fig. 58. The heavy solid lines indicate the powers at which

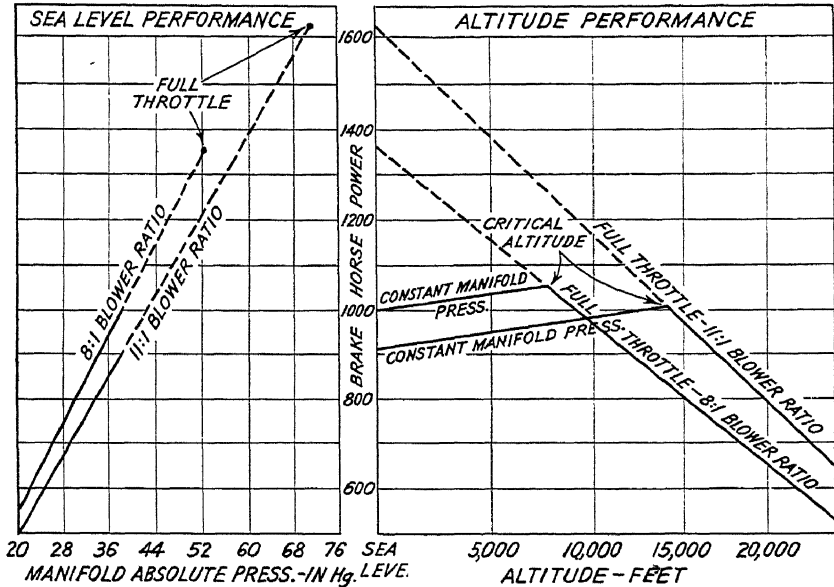

Fig. 58.—Performance curves for two engines differing only in the gear ratio between the supercharger impeller and the crankshaft. All the above curves are for operation at one crankshaft rpm.

operation was safe, while the dotted lines are for performance in the range where detonation would be likely to occur.

For all-round performance, a compromise must be made. Greater altitude power can be obtained by sacrificing some sea-level performance. Instead of operating the engine at full throttle at low altitudes, a limit may be placed on the manifold pressure until an altitude is reached at which full-throttle operation is safe. The result is that the upper part of the performance chart is, in effect, cut off, for the engine must not be operated in that range. Engines are usually equipped with a supercharger

which will provide ample power capacity for take-off operation from airports located as much as 3,000 or 4,000 ft above sea level. If the maximum power output were desired at higher altitudes, higher gear ratios could be used but the maximum power output would have to be further restricted.

Engine performance is often represented by charts similar to Fig. 58. The lines sloping upward to the right represent constant-manifold-pressure operation at approximately rated power. The altitude at which full throttle is reached is called the *critical altitude* for that blower ratio. Note that less horsepower is available for take-off and sea-level rated power operation when an 11:1 instead of an 8.0:1 blower ratio is used. On the other hand, the higher blower ratio gives more power at altitude.

Single-stage Two-speed Superchargers.—One way to obtain the maximum performance at both sea level and altitude is to use a two-speed blower, *i.e.*, to provide a clutch to permit a change in the gear ratio between the crankshaft and the impeller shaft. With such an arrangement, it is possible to operate in the lower blower ratio at low altitudes. When the altitude is reached at which the full-throttle power in the lower blower ratio has fallen off to the extent that it equals the power delivered at the maximum allowable manifold pressure in the higher blower ratio, the gear ratio may be changed and the climb continued at constant manifold pressure. Thus an engine equipped with a two speed supercharger has not one but two critical altitudes, one for each blower ratio (see Fig. 58). This makes possible better altitude performance without a penalty on sea-level power. Of course, a small increase in weight and greater complication accompany such an installation.

Partly because of the limiting effect of the strength of engine parts, partly to improve airplane performance below the critical altitude, and partly to simplify performance specifications, the altitude rated power below the critical altitude is usually given a constant value. Some engine specifications have been prepared on the basis of operation at a constant manifold pressure below the critical altitude, however. This gives a power which increases somewhat with altitude as in Fig. 58.

Two-stage Geared Superchargers.—The losses accompanying a high supercharge are due largely to the increase in temperature of the compressed air. The engine performance can be improved

considerably over that obtainable with a single-stage supercharger by the use of a two-stage supercharger with an intercooler between the first and second stages. The first stage through which the air passes is generally referred to as the *auxiliary stage* because a declutching arrangement is usually provided so that it may be disengaged at low altitudes. If two gear ratios are provided in the auxiliary stage, nearly the optimum performance for an engine with a gear-driven supercharger can be obtained at all altitudes between sea level and the critical altitude with the auxiliary stage in the high gear ratio. This is a widely used arrangement because it involves a considerable improvement in performance at the expense of only a few pounds more weight.

The power required to drive the supercharger increases rapidly as the altitude at which the engine is designed to give high performance is increased. If the auxiliary stage is driven by the engine, this power must be deducted from that delivered to the crankshaft by the cylinder. Both the net power available at the propellershaft and the fuel economy suffer as a result. A two-stage engine with a two-speed auxiliary stage designed to give the best possible performance at an altitude of 27,000 ft, for example, would of necessity have a rated power at that altitude roughly 10 per cent lower than at sea level, and a specific fuel consumption 10 per cent higher than at sea level because of the power taken from the crankshaft to drive the auxiliary stage.

Exhaust Turbosuperchargers.—The engine exhaust gases can be expanded through a turbine by imposing some back pressure on the exhaust ports. The amount of power obtainable from the turbine increases rapidly with altitude, so that it is always greater than that required to supercharge the engine. If a turbine driven by the exhaust gases is coupled directly to a supercharger and the unit installed in the exhaust and induction systems of an engine, excellent altitude performance can be obtained from the engine. Since the power required for the supercharger is not taken from the crankshaft, no increase in specific fuel consumption should occur at any altitude, and no loss in rated power should result until the capacity of the turbine or of the turbine-driven supercharger is exceeded. Flight tests have shown that only a part of the power obtainable in this fashion need be used so that the exhaust back pressure on the

engine need not be kept to its sea-level value. Back pressures of only about 25 in. Hg abs. are required to give enough supercharge to maintain sea-level rated power at 30,000 ft.

Figure 59 shows a set of altitude performance curves for an engine supercharged in various ways. The altitude performance line for the engine operating without a supercharger is shown for comparative purposes. Control of the exhaust turbosupercharger would be accomplished with an exhaust waste gate placed in the exhaust system ahead of the supercharger. For sea-level and low-altitude operation this waste gate would be nearly wide

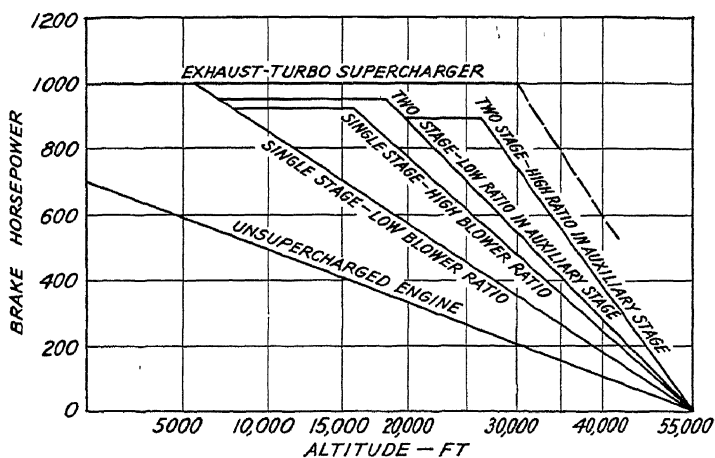

FIG. 59.—Altitude performance obtainable from an engine equipped with each of several conventional engine-driven supercharger arrangements, as well as with an exhaust turbine-driven supercharger.

open to permit most of the exhaust gas to by-pass the supercharger. The greater power needed for high-altitude operation would be obtained by closing the waste gate. This would force more exhaust gas through the turbine and cause a speeding up of the impeller and a greater pressure rise through the supercharger. This process may generally be continued until the waste gate is closed or until the maximum allowable turbine wheel speed is reached. Higher speeds would cause greater stresses in and possibly failure of the turbine buckets.

Note that rated power operation above the critical altitude lies on a straight line drawn through a point of zero horsepower and approximately 55,000 ft for all engines having gear-driven superchargers. The performance with an exhaust turbosuper-

charger would fall off in a similar fashion except that it appears to pass through zero at a higher altitude.

FACTORS AFFECTING POWER OUTPUT

Standard Atmospheric Conditions.—Variations in atmospheric conditions affect the amount of air inducted by the engine and hence its power capacity. Engine specifications for sea-level operations are based on standard air conditions, *i.e.*, 29.92 in. Hg dry air pressure and 60°F air temperature at the carburetor inlet. This forms a basis for the comparison of different engines or for the same engine under different operating conditions. For example, all full-throttle 2,000-rpm points run with a given engine should correct to the same value regardless of the barometric pressure or the weather. In a similar manner, altitude performance is based on a standard set of altitude pressures and temperatures at the carburetor inlet. Table IX in the Appendix gives the standard temperature, pressure, and the corresponding altitude-density ratio for altitudes from sea level to 50,000 ft. This table was established by the Bureau of Standards and the N.A.C.A. It is used throughout the aeronautical industry for all types of calculation involving altitude.

Correction of Full-throttle Power Output.—Approximate correction of power output for changes in atmospheric conditions is a simple matter. It has been shown that the power which an engine will deliver at full throttle is directly proportional to the weight of air taken into the cylinders each cycle. This, in turn, is nearly proportional to the air pressure at the inlet to the carburetor. Correction for variations in carburetor air inlet temperature is a little more complicated. A change in air temperature has two effects—it decreases the density, and it increases the velocity at which air will flow through restrictions in the induction passages with a given pressure drop available. The net correction for a temperature change from standard conditions is inversely proportional to the square root of the absolute temperature ratio. This is the same correction used for the weight of a gas flowing through an orifice in any type of metering system. Thus, the generally used formula for correction of engine full-throttle power output to standard sea-level conditions is

$$\text{bhp} = (\text{full-throttle corrected hp}) \quad (18)$$

where bhp = actual brake horsepower developed.

dap = dry air pressure, in. Hg.

t = carburetor air inlet temperature, °F.

P_s = scoop pressure above atmospheric, in. Hg.

The allowance for scoop pressure is necessary because a good engine installation will provide a considerable pressure increase, or *ram*, at the upper flange of the carburetor owing to the impact pressure set up by the air stream striking the air scoop. A poor air scoop, on the other hand, may throttle the air ahead of the carburetor. In either case, the pressure at the carburetor inlet flange would differ from atmospheric pressure. As indicated in the above formula, this may be corrected for by simply adding the scoop pressure to the dry air pressure.

Effect of Water Vapor.—The term *dry air pressure* means that the pressure at the carburetor inlet should be based on the so-called dry barometer. The reason for this is that water vapor in the air consumed by an engine is not combustible and serves no useful purpose. An engine operating during rainy weather in summer when the vapor pressure may be as much as 0.8 in. Hg would be at a serious disadvantage if its performance were compared with that of an engine operating on dry air with the same total barometric pressure at the carburetor inlet. The water-vapor pressure may be obtained from a chart such as that given in Fig. 249 of the Appendix after the wet- and dry-bulb air temperatures have been found from a sling psychrometer or some similar instrument. The dry barometer may be found by subtracting the water-vapor pressure from the total barometer reading after correcting the latter for temperature. This correction is ordinarily made only for sea-level test work.

Correction of Full-throttle Manifold Pressures.—Data from dynamometer or flight tests must be corrected to standard conditions before they are plotted to give an engine performance chart. Since the full-throttle manifold pressure is affected by both the barometric pressure and the air temperature, it must also be corrected. Rigorously accurate correction involves the characteristics of the supercharger and is somewhat involved.³ An approximate correction can be made by considering the

manifold pressure as being directly proportional to the barometric pressure. This gives good accuracy if the carburetor air inlet temperature is not far from 60°F.

When full-throttle points are plotted in the construction of a performance chart, it will be found that they often fall below the straight line drawn through the other points, owing to factors to be discussed later. The straight line for the sea-level performance at that rpm *should be terminated at the corrected full-throttle manifold pressure even though this gives a higher full-throttle horsepower than that found in the test.*

Correction of Part-throttle Power Output.—Engine power output is often determined from a performance chart from the manifold pressure and rpm. Such power determinations must be corrected for variations in atmospheric conditions. It happens that the part-throttle sea-level horsepower of an engine is unaffected by changes in the pressure of air at the carburetor intake—if the pressure there decreases it is necessary only to open the throttle enough to hold the same map. This holds true until full throttle is reached. The reason for this is that the throttling losses in the carburetor are such that engine power is unaffected by them if the map is held constant. At full throttle, of course, this is no longer possible, and so further decreases in air pressure should result in decreased manifold pressure.

Air temperature, on the other hand, affects air density in the intake manifold and so has its effect on both part-throttle and full-throttle operation. Correction of part-throttle points for carburetor air inlet temperature is not so well established as for full-throttle points because it depends on both the engine and the supercharger. It is generally made in the same way, *i.e.*, the power developed at a given rpm and manifold pressure is taken to be inversely proportional to the square root of the absolute-temperature ratio. Expressed as a formula the correction becomes

$$\text{bhp} = (\text{part-throttle corrected hp}) \frac{\sqrt{460 + t_s}}{460 + t} \quad (19)$$

where t_s is the standard air temperature.

The term *standard air temperature* was introduced for the part-throttle correction because it generally must be used at

altitudes where the standard temperature is not 60°F but some lower temperature. The standard altitude temperature is generally given in the form of a curve on the lower part of the altitude performance chart (see Fig. 56).

A convenient approximation that is sufficiently accurate for most purposes is given by a correction of 1 per cent for every 10°F variation from standard conditions. This rule is especially useful since the calculation becomes so simple that it can be performed without a slide rule or tables.

The manifold pressure for engine test work conducted at sea level should be based on the dry air pressure because the water-vapor pressure may be relatively large. Since it is ordinarily quite small above a few thousand feet, it is usually neglected in routine flight work.

Use of Corrections.—The corrections as given are for the determination of actual brake horsepower from the power indicated by a performance chart constructed on the basis of standard conditions. The same formulas also apply to the correction of brake-horsepower output, as obtained on a dynamometer stand, to standard atmospheric conditions. When used in this manner, the unknown then appears in the right-hand side of the equations given above.

Other Factors Affecting Power Output.—The performance charts and basic corrections discussed have been made on the basis of assumptions that do not hold without some qualification. Therefore, it is necessary to consider the other variations to be expected and the factors responsible.

Effect of the Supercharger.—It has been shown that accurate correction of the full-throttle power of a supercharged engine involves the characteristics of the supercharger because both air temperature and air density affect the pressure rise that it will deliver.³ The corrections are sometimes applied to the full-throttle manifold pressure, and the power corrected accordingly. All methods of correction involving the supercharger characteristics are so complicated that special charts constructed for each model engine are generally used. Corrections of this type are used only for very exact work involving performance guarantees and performance-chart construction.

Effect of Fuel-Air Ratio.—Probably the most important factor affecting power output is the fuel-air ratio of the charge going to

the cylinders. If the mixture is too rich, a loss in power will result. On the other hand, if the mixture is too lean, detonation, backfiring, or sudden "cutting out" of the engine may occur, all of which result in a severe penalty on power if not actual stoppage of the engine. Even if none of these occurs, operation at a mixture richer or leaner than that for the maximum power results in a power lower than that indicated by the performance chart. The *best-power mixture* may be defined as that at which the maximum brake horsepower is obtained at a given manifold pressure and rpm. *Best-power specific fuel consumption* (*best-power spec.*) is the fuel consumption at best power in pounds per brake horsepower per hour. Engines are usually run with

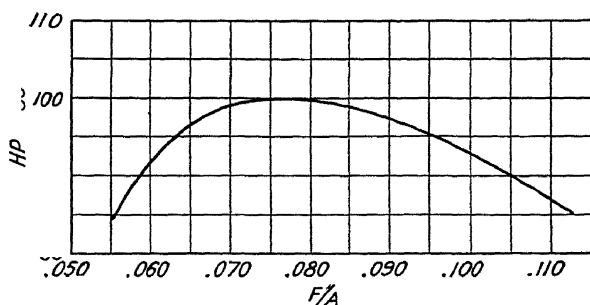

FIG. 60.—Percentage loss in brake horsepower as the fuel-air ratio is varied from the best power mixture.

mixtures richer than best power in the high-power range and leaner than best power in the cruising range. The effect of the mixture ratio on the percentage brake-horsepower loss at constant manifold pressure is shown in Fig. 60. Note that the power falls off abruptly as the mixture is "leaned" beyond the best-power mixture. Figure 60 must be considered as approximate, for it varies with the engine model.

The effect of mixture ratio on the sea-level manifold-pressure chart in actual practice is to cause the constant-rpm lines to drop off at the upper end, so that the power is less than that indicated by the chart in the upper horsepower range. The actual amount of this departure usually does not exceed 6 or 8 per cent with the carburetor setting specified for the engine.

Effect of Cylinder-head Temperature.—In air-cooled engines, another factor tending to reduce engine output, especially in the high-power range, is cylinder-head temperature. This seems to

affect the power in the same general manner as does the carburetor air temperature, *viz.*, inversely as the square root of the absolute-temperature ratio. The change in charge temperature and hence in density is proportional to the change in cylinder-head temperature but is considerably smaller so that the effect on power is much less than would be caused by a corresponding change in carburetor air temperature. Since most installations have provision for varying the cooling air flow and since the distribution of the air flow across the fins of the cylinder barrels and heads varies widely with the form of the installation, the effect of this factor is complicated by variables difficult to measure. As a result, no allowance is ordinarily made in flight for the effect of cylinder-head temperature on engine power. It is usually taken into consideration, however, in the preparation of engine-performance specification charts from dynamometer test data.

Variations between Individual Engines.—Engine-performance charts and power specifications are based on a calibration conducted on one or two engines of a basic model. The resulting charts are then assumed to apply to all engines of that model which are manufactured. It is not possible to do this with absolute accuracy. This is one of the reasons engine-power specification charts are ordinarily guaranteed by the manufacturer to be accurate only to within a few per cent. However, the variation from one engine to another in production is surprisingly slight. In a group of engines in the 1,000-hp class, 95 out of 100 will probably deliver rated power at a manifold pressure within $\frac{1}{2}$ in. of that specified on the performance chart. This represents a variation of about $1\frac{1}{2}$ per cent from the mean.

Another related variation which may amount to considerably more is that between the power output of an engine when it is new and the power output of the same engine after it has seen thousands of hours of service. The variation in engine power due to the wear and tear of service life may amount to as much as 8 per cent. It is difficult to assign this loss in power to any particular effect of wear or other changes that may take place in service as it is due to the combined effects of a number of different factors. Since the individual effect of each of these factors is small, it is difficult to separate and evaluate each of them.

Net Effect of Operating Conditions.—In general, it may be said that each of the above deviations in engine power from that given on the engine-power specification chart is of such a nature that a loss in power results. Since too much cooling will cause excessive airplane drag, the airplane manufacturer usually designs the installation so that the engine runs hotter than it probably did when it was calibrated. The effects of wear are also such that they result in a loss of power, while, by definition of best power, any variation in fuel-air ratio from that optimum used during the calibration would inevitably result in a power loss. The cumulative effect of these factors is not great even so, except in the high-power range where the horsepower of an engine as estimated and calculated from the performance chart may be, in extreme cases, as much as 10 or 15 per cent higher than the actual brake-horsepower output.

ENGINE FUEL-CONSUMPTION CHARACTERISTICS

Effects of Fuel-Air Ratio.—The effect of fuel-air ratio on the pressures and temperature developed during the cycle was discussed in Chap. III. It was pointed out that the indicator-card area was greatest at a fuel-air ratio slightly richer than the chemically correct mixture and that either an increase or a decrease in the fuel-air ratio would give less power per pound of mixture. It happens, though, that the power loss resulting from mixtures 10 or 20 per cent leaner than that for best power is not large as compared with the reduction in fuel consumption. Of course, if the mixture is made too lean, it will not ignite readily and irregular firing, or "rough" engine operation, will result. On the other hand, mixtures richer than that for best power may be absolutely necessary to inhibit detonation. The increased power thus made possible is obtained at the price of greatly increased fuel consumption. The determination of the fuel-air ratios at which an engine can or should be operated together with the resulting specific fuel consumptions is a major problem in the development of a new engine. Upon the results of such an investigation hinge the fuel-consumption characteristics of the engine and, ultimately, the range of the airplane in which the engine is installed.

Mixture-control Curves.—The most convenient method of investigating the effect of a change in mixture strength on the

power and fuel economy of an engine is to run a *mixture-control curve*. This may be done in a number of ways, all of which involve manipulation of a lever on the carburetor. This lever, called the *mixture control*, can be used to vary the fuel flow obtained with a given air flow.

The *constant-throttle mixture-control curve* is one of the easiest to understand. The throttle may be locked in a fixed position

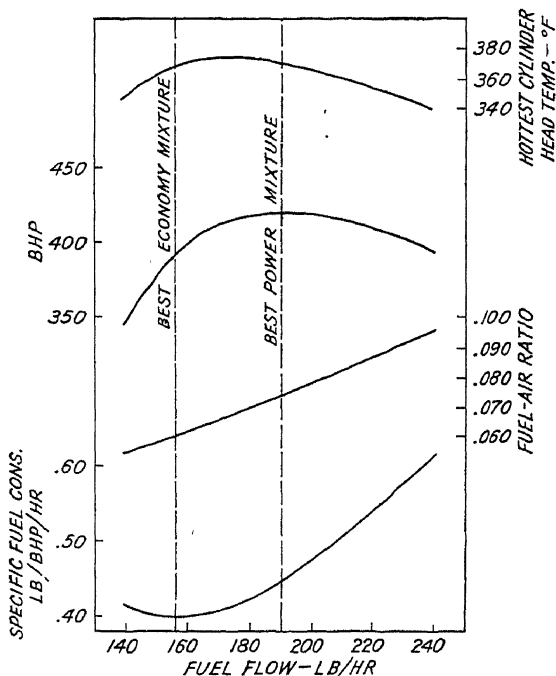

Fig. 61.—Constant-throttle mixture-control curve run in the cruising range of a large radial engine. (Wright Aeronautical Corp.)

and the dynamometer load varied to maintain a constant rpm as the mixture is leaned out. Readings should be taken at four to eight points at successively leaner mixtures. The brake horsepower, fuel-air ratio, and specific fuel consumption can be determined and plotted against fuel flow to give a set of curves such as those of Fig. 61. The peak of the horsepower curve defines the *best-power* mixture, while the lowest point in the specific-fuel-consumption curve defines the *best-economy* mixture.

The data from a set of constant-throttle mixture-control curves are difficult to use for the construction of charts for performance-

analysis work because each point is at a different power. The *constant-power mixture-control curve* is much better suited to this purpose. It is run by setting the throttle and dynamometer load to give the speed and power desired. After taking a point for the full rich position of the mixture control, the mixture would be leaned out somewhat, the throttle readjusted to keep the speed and power constant, and a second reading taken.

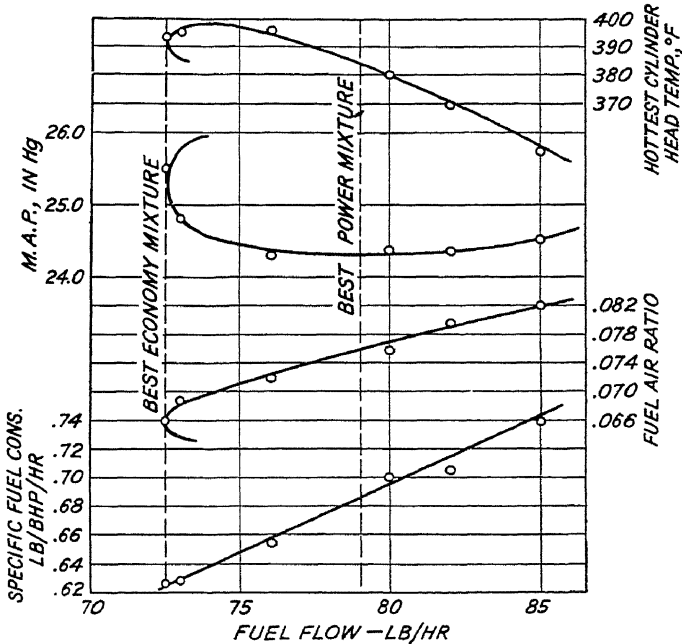

FIG. 62.—Constant-power mixture-control curve run at 116 hp and 1,740 rpm with a Lycoming R-680 radial engine. (Daniel Guggenheim School of Aeronautics, New York University.)

This would be repeated until rough engine operation occurred. Since the power would remain constant throughout such a curve, the best-power mixture would not be defined by a plot of power output against fuel flow. As indicated by Fig. 62, however, it is possible to plot manifold pressure against fuel flow and in that way determine the best-power mixture. Figure 62 shows manifold pressure, fuel-air ratio, and specific fuel consumption for a typical constant-power mixture-control curve. The best-power mixture is defined by the lowest point in the manifold-pressure curve, for that indicates the point at which

the least amount of manifold pressure was required to obtain that power. The best-economy mixture and the minimum specific fuel consumption are given by the point having the lowest fuel flow.

A peculiar characteristic of constant-power mixture-control curves is also evident in Fig. 62. As the mixture is leaned beyond the point for best economy, the curves "hook." Operation in this range tends to be unstable. Data taken for several mixture-control curves run in succession at the same power and speed would fall on the same curve up to the point of best economy, but at leaner mixtures the points would scatter widely. Another point which should be noted is that a plot of specific fuel consumption against fuel flow should be a straight line if the power is maintained constant. This provides a good check on the data, for points which do not fall on the straight line indicate that an error occurred in either the data or the calculations or that the power was not kept constant.

Detonation Limitations.—As has been pointed out before, the engine must not be operated under detonating conditions. Detonation at the higher bmep's in a highly supercharged engine is usually prevented only by the use of rich mixtures. Often, mixture-control curves must be terminated before the best-economy point is reached because detonation sets in as the mixture is leaned out. For engines operating on 100-octane fuel with 6.7:1 compression-ratio pistons, this will generally occur only at bmep's of more than 145 psi.

Effects of Valve Overlap and Manifold Pressure.—A considerable amount of valve overlap is necessary for aircraft engine operation at high speeds. If the manifold pressure is appreciably greater than the exhaust back pressure at low speeds, the large valve overlap will give part of the fresh charge that enters the cylinder the time to pass out through the exhaust port before the exhaust valve closes. This will cause an increase in the consumption of both fuel and air. The result will be an increase in specific fuel consumption.

Effects of Mechanical Friction.—The most economical indicated specific fuel consumption obtainable in an engine is practically independent of speed or power output except as limited by detonation or as affected by valve overlap as shown above. The power required to turn the engine over, or friction horse-

power, however, increases rapidly with rpm. Figure 63 shows curves of friction plus supercharger horsepower for a high-performance supercharged engine, plotted against air flow for various rpm. Note how small the effect of air flow is as compared with that of rpm. Since the brake horsepower is equal to the difference between the indicated and the friction horsepowers, it can be reasoned from this that the lowest specific fuel consumption obtainable at a given power output would occur at the lowest speed at which that power could be obtained. This conclusion must, of course, be tempered by consideration of the

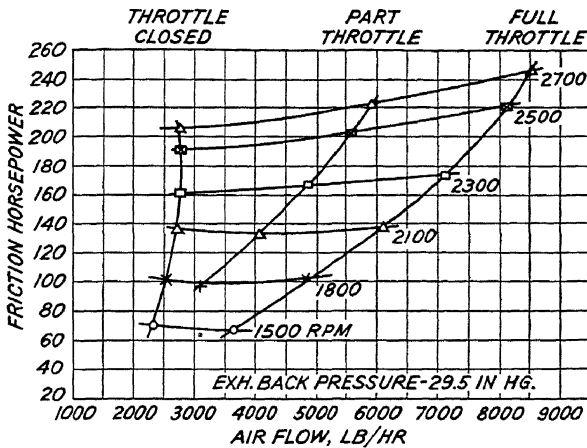

FIG. 63.—Friction horsepower of an air-cooled radial engine of about 1,200 hp. (Hersey, *I.A.S. Jour.*, vol. 9, No. 10, August, 1942.)

effects of detonation and of the loss of fresh charge due to high intake manifold pressures and valve overlap.

Propeller-load Fuel-consumption Characteristics.—Until the beginning of the Second World War, most engines were operated at powers and speeds that were always not far from being on a propeller-load curve. This made the problem of the determination and presentation of engine fuel-consumption characteristics relatively simple. A series of mixture-control curves would be run through points on a propeller-load curve. The best-power and best-economy specific fuel consumption (or sometimes fuel flow) could be obtained from these curves and plotted against rpm. The carburetor would then be adjusted, or set, to give a fuel flow at any rpm which would be approximately that desired. That is, leaner mixtures would be provided in the

cruising range to give good economy, while richer mixtures would be used in the high-power range to inhibit detonation. Figure 64 shows a set of curves for the best-power and best-economy fuel-air ratios and specific fuel consumptions plotted against per cent rated power for operation along a propeller-load curve. Because of the richer mixtures required to inhibit detonation and the greater friction horsepower, this shows a somewhat greater increase in specific fuel consumption than that indicated in Fig.

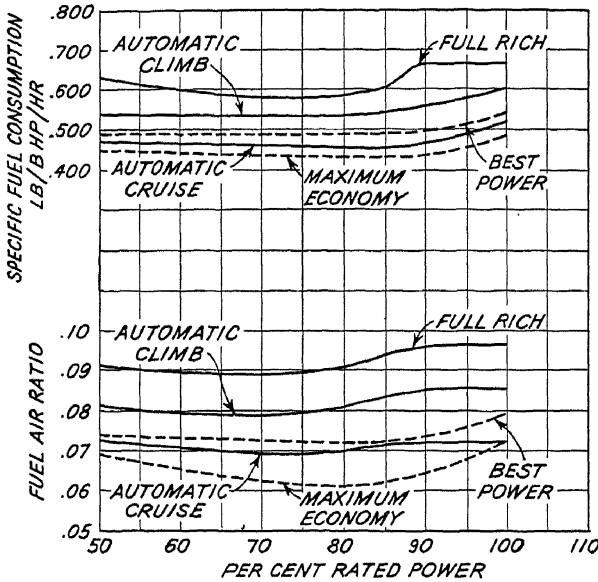

FIG. 64.—Mixture ratio and specific fuel consumption vs. percentage rated power of a Wright Cyclone model R1S20G5 operated on 92-octane fuel. (*Young, S.A.E. Trans., vol. 32, 1937.*)

54. The difference is even more pronounced for engines operating at still higher bmep's.

Fuel-consumption Characteristics over the Entire Operating Range.—Variable-pitch propellers, together with intensive investigations of the minimum fuel consumption possible, led to the use of much higher powers at low rpm for cruising operation. This necessitated a more complete presentation of engine fuel-consumption characteristics. One way of presenting a complete picture of the minimum practicable specific fuel consumption for a particular engine is shown in Fig. 65 as a three-dimensional surface. The ordinate of the surface is the specific fuel consump-

tion, while brake horsepower and rpm each serve as coordinates for the plane at the base of the figure. The lowest specific fuel consumption shown occurs at about 500 hp and 1,100 rpm. This

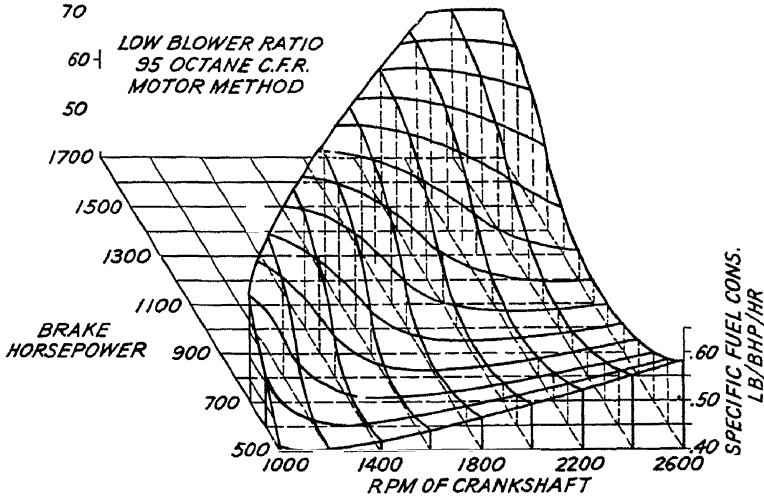

FIG. 65.—Minimum specific fuel consumption for normal flight operation. (Pierce, *S.A.E. Trans.*, vol. 35, 1940.)

would be obtained with a bmep of about 135 psi and a manifold pressure of about 28 in. Hg.

The same set of characteristics can be presented in a more usable form. Figure 66 shows a set of curves giving the minimum specific fuel consumption at various cruising powers as

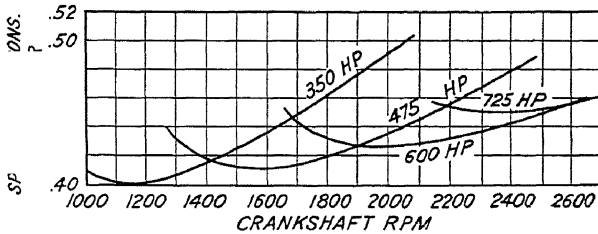

FIG. 66.—Series of constant-power curves showing the effect of rpm on the lowest practicable specific fuel consumptions of a typical engine.

functions of engine rpm. Charts like this, coupled with curves of propeller efficiency and of the thrust horsepower required for various airplane flight conditions, make possible the determination of the optimum engine power and rpm for maximum range or maximum endurance.

Effect of Altitude.—Altitude affects the minimum specific fuel consumption obtainable in several ways. If the power of an engine fitted with a single-stage single-speed supercharger is kept constant as the altitude is increased, the throttle may be opened until full throttle is reached. This will have virtually no effect on the specific fuel consumption. If the power is to be maintained to still higher altitudes, the rpm must be increased. This would increase the friction horsepower and thus increase the specific fuel consumption.

The effect of altitude on the fuel-consumption characteristics of an engine equipped with various types of supercharger is a complex one. In general, increasing the amount of supercharge by taking power from the engine to drive the supercharger results in a reduction in fuel economy. The specific fuel consumption of an engine having an exhaust turbosupercharger, however, is not appreciably affected by altitude.

References

1. GAGG, R. F., and E. V. FARRAR: Altitude Performance of Aircraft Engines Equipped with Gear-driven Superchargers, *S.A.E. Trans.*, vol. 29, 1934.
2. PIERCE, E. F.: Altitude and the Aircraft Engine, *S.A.E. Trans.*, vol. 35, 1940.
3. HERSEY, D. S.: Correction of Engine Output to Standard Conditions, *I.A.S. Jour.*, vol. 9, No. 10, August, 1942.

CHAPTER VII

CARBURETION

Metering the fuel supplied to an engine presents one of the most complex and difficult problems of aircraft-engine development and operation. As pointed out in the previous chapter, if the engine is not supplied with just the right fuel-air mixture ratio under all conditions, the performance will be penalized, and in some cases the engine may be severely damaged. Much expensive research and development work has been devoted to the problem, with the result that the aircraft-engine carburetor has become a complicated but highly accurate mechanism. The operating requirements of the carburetor together with the construction and characteristics of the most important types form the subject material for this chapter.

PRINCIPLES OF CARBURETION

Engine Requirements.—It was pointed out in the preceding chapter that the fuel-air ratio required by an aircraft engine varies with the speed and power. The mixture in the idle range should be rich to give smooth idling. The mixture in the cruising range is generally made as lean as possible to give good fuel economy. The mixture at high-power outputs, especially in air-cooled engines, should be rich both to inhibit detonation and to decrease the amount of cooling necessary.

It was shown that engine power output is proportional to the air flowing into the induction system. Carburetors are made to meter on the basis of air flow, and thus it is often convenient to plot fuel-air ratio against air flow as in Fig. 67. This shows the requirements of a high-performance air-cooled engine for operation on a propeller-load curve. The upper curve is for relatively rich mixtures that would give smooth, safe operation under all conditions, while the lower curve represents the leanest practicable mixtures for best economy. All types of aircraft carburetor must be made to regulate the fuel flow in accordance

with the air flow to provide the mixture ratios indicated by a set of curves such as those of Fig. 67.

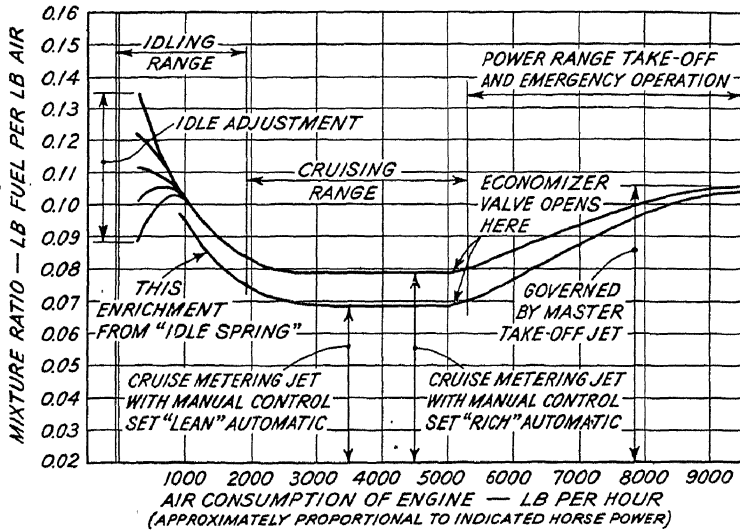

FIG. 67.—Fuel-air ratio requirements of a conventional high-performance aircraft engine as a function of air flow into the carburetor. (Bendix Aviation Corp.)

The Simple Carburetor.—The simple carburetor has been used to meter fuel to gasoline engines from the time they first came into use. Essentially, it consists of two orifices in parallel. The first, the *air venturi*, meters the air flow. The second, the *fuel jet*, meters the fuel flow. Since the flow through an orifice is proportional to the square root of the pressure drop across it, the fuel flow to an engine will be proportional to the air flow if the pressure drop across the fuel-metering jet is made proportional to that across the air venturi.) In the simple carburetor a flow chamber which maintains a constant level in the fuel reservoir is used to make the absolute pressure of the fuel approaching the jet equal to that of the air approaching the venturi. The fuel jet is so placed that it discharges directly into the throat of the air venturi. The static air pressure at this point is less than the pressure at the carburetor inlet by an amount proportional to the pressure drop across the air venturi, but several times the latter in magnitude. Thus the pressure drop across the fuel jet is at all times proportional to that across

the air venturi. Hence, the ratio of the fuel flow to the air flow should be constant. The principle of operation is simple and should be thoroughly understood, for it is essential to an understanding of carburetion.

The metering characteristics of a simple carburetor are shown in Fig. 68. The sharp drop in fuel-air ratio at low air flows is due partly to the viscosity of the fuel and partly to the fact that the discharge nozzle is usually placed a little above the fuel level in the float chamber to prevent fuel overflow and flooding of the induction system when the engine is stopped.

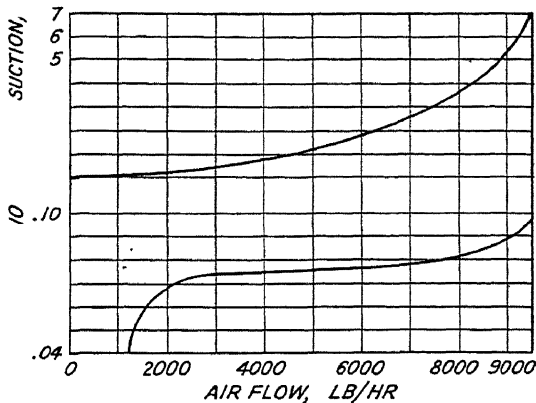

Fig. 68.—Metering characteristics of a simple carburetor.

In the central portion of the range, the simple carburetor gives a practically constant fuel-air ratio. The principal part, or main metering system, of many carburetors is much like that of a simple carburetor and has the same metering characteristics.

A curve showing the suction at the throat of the venturi is also given in Fig. 68. This suction is often called the *basic metering head*. It is proportional to the square of the volume of air flowing through the venturi. The air weight flow is nearly proportional to the volume flow at the lower air velocities—*i.e.*, those giving venturi suction of less than about 4 in. Hg. At higher suction, the density of the air passing through the throat of the venturi is reduced sufficiently to cause the pressure drop to increase at a more rapid rate. This is the factor responsible for the rise in the fuel-air-ratio curve in that region, for the fuel is incompressible and so is not similarly affected. Mixture enrichment caused in this way is referred to as *velocity enrichment*. Although most

carburetors are designed to operate with low venturi suction at sea level, the reduced densities at high altitudes often cause velocity enrichment.

Effect of Altitude.—The reduced air densities at high altitudes have a pronounced effect on the carburetor. This effect can be deduced from the basic equation for flow through an orifice,

$$V = \sqrt{2gH}$$

where V = air velocity at venturi throat, fps.

Δp = pressure drop, lb per sq ft.

w_0 = specific weight of air at standard sea-level conditions, lb per cu ft.

σ = altitude-density ratio,

But

$$H = \frac{\Delta p}{w_0 \sigma}$$

Hence,

$$V = \sqrt{2g \frac{\Delta p}{w_0 \sigma}} \quad (20)$$

If the effect of the reduced density at the throat of the orifice is neglected, the weight of air flowing is given by

$$G = VACw_0\sigma \quad (21)$$

where G = weight of air flowing, lb per sec.

A = area of the orifice opening, sq ft.

C = orifice coefficient (approximately unity for a venturi).

Substituting Eq. (20) in Eq. (21), we obtain

$$G = ACw_0\sigma \sqrt{2g \frac{\Delta p}{w_0 \sigma}} = AC \sqrt{2gw_0\sigma \Delta p}$$

For a given orifice, this becomes

$$G = K \sqrt{\sigma \Delta p} \quad (22)$$

where K is a constant for that orifice. This relation is important, for it applies not only to the carburetor but to other restrictions to air flow such as the cooling air flow over the cylinders, etc.

Equation (22) shows that, if the mass flow of air through the carburetor is maintained constant, the metering head (the pres-

sure difference between the venturi inlet and throat) will be inversely proportional to the altitude-density ratio. Unless some means of compensation is provided, this will cause the fuel flow to vary inversely as the square root of the altitude-density ratio because the density of the fuel will be constant. For example, at an altitude of 21,700 ft the altitude-density ratio is 0.5, so that the mixture would be approximately 42 per cent richer than at sea level. Actually, the velocity enrichment mentioned in the preceding section would cause the enrichment to be even greater.

Idle Enrichment.—When Fig. 68 is compared with Fig. 67, it is evident that some arrangement for idle enrichment is necessary. This may be accomplished by placing a small fuel-metering jet in parallel with the main jet but discharging it into the air stream behind the throttle valve. The throttle butterfly valve is placed on the engine side of the venturi to avoid disturbing the air flow through the air-metering venturi. At low power, the throttle valve is nearly closed to keep the air flow low. As a result, an area of very low pressure exists immediately behind the throttle valve. This makes available a high metering head, which is used to induce a flow of fuel through an idle jet. As the throttle is opened, the low-pressure area disappears, the fuel flow through the idle jet ceases, and the carburetor meters all the fuel through the main jet.

Power Enrichment.—To obtain the mixture enrichment necessary at high-power outputs a second auxiliary metering system is used. The simplest types make use of a valve operated by the throttle, with a linkage such that the valve remains closed until the throttle has been opened to a point corresponding to the power at which the enrichment is desired to begin.

Acceleration.—Facility for rapid acceleration is one of the important requirements of an aircraft engine. When the throttle is opened suddenly, the fuel-air mixture entering the cylinders tends to be lean for a few moments. Consequently, the simple carburetor with only idle and power enrichment will deliver too lean a mixture for the first second or so after the throttle is opened, with the result that the engine will misfire, perhaps backfire, and will not accelerate smoothly and rapidly. Provision is usually made for immediate mixture enrichment under acceleration conditions. In some types, an accelerating

pump is linked to the throttle. Sudden opening of the latter will pump extra fuel through an accelerating jet into the induced air to give the momentary enrichment necessary.

Fuel Dispersion.—A further modification of the simple carburetor was found desirable to obtain a more complete atomization and vaporization of the fuel. Fuel that enters the combustion chamber in the form of droplets cannot burn properly. For good fuel economy, it should be completely vaporized and mixed with the induced air. As an aid to fuel vaporization, it has been the practice to place an *air bleed* in the fuel-metering system so that air is drawn in through the pinhole orifice of the air bleed to be mixed with the fuel below the jet and thus cause the latter to break up into fine, easily vaporized droplets before passing through the fuel discharge nozzle into the induced air.

Fuel-Air Mixture Control.—A device that gives some manual control over the fuel-air ratio has been found to be valuable in aircraft carburetors. This may be in the form of a variable restriction such as a needle valve that can be moved part way into the main jet to restrict the opening and reduce the fuel flow. Such a restriction is operated by a separate control, called a *mixture control*, which is normally placed beside the throttle control in the pilot's cockpit of the airplane. The mechanism in the carburetor is so designed that when the mixture control is fully open, or in the *full-rich* position, it has little or no effect on the fuel flow. It may be gradually closed, however, to reduce the fuel flow and lean out the mixture. In many carburetors, it is so designed that the entire fuel flow to the engine may be shut off; the position for this is called *cutoff* or *idle cutoff*.

THE STROMBERG FLOAT-TYPE CARBURETOR

Stromberg float-type aircraft-engine carburetors have been widely used. They provide excellent examples of a simple carburetor modified to meet the specialized needs of aircraft engines. Although the different models vary considerably in some details, they are all similar. Figure 69 is a diagrammatic sketch of a section through an NAR4B carburetor. The principal elements are shown and labeled. This diagram will be found to be an invaluable aid to an understanding of the float-type carburetor.

Main Metering System.—The main metering system (Fig. 69) is easily recognized as a simple carburetor. The round float

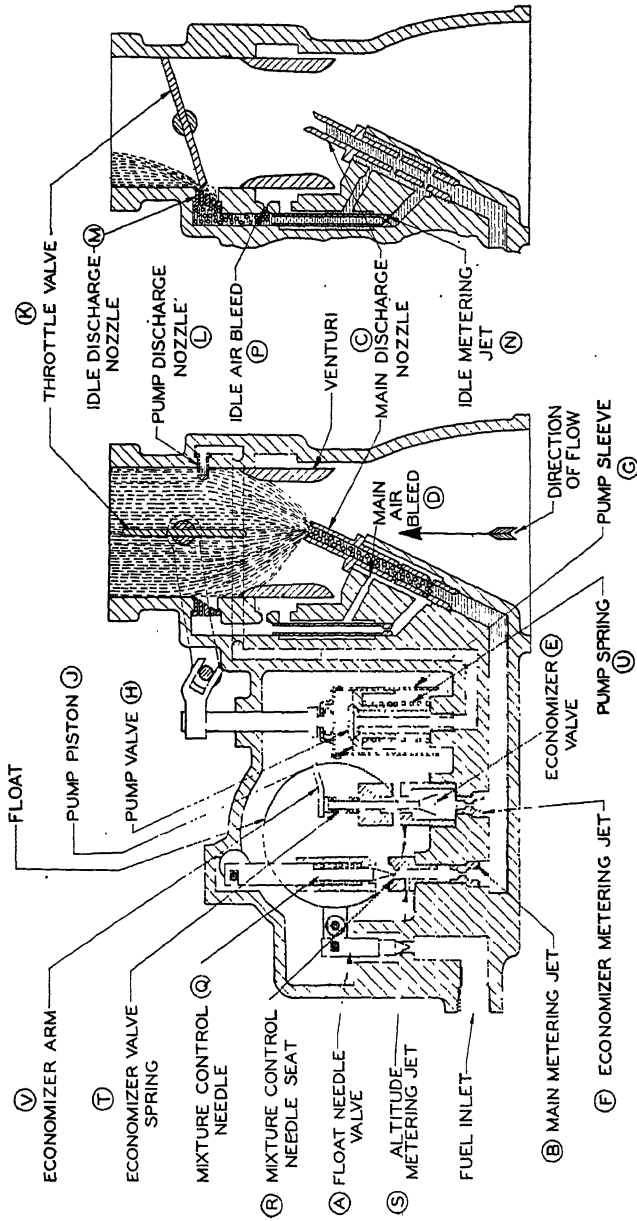

FULL THROTTLE

IDLING

Fig. 69.—Schematic diagram showing the construction of a Stromberg NAR4B carburetor. (Bendix Aviation Corp.)

controls the float needle valve to maintain a constant fuel level in the float bowl. The main jet meters the fuel flow from the float bowl to the discharge nozzle in the throat of the venturi. A throttle valve above the venturi provides control over the air flow to the engine. The main air bleed is supplied with air under the pressure existing ahead of the venturi. Air from this air bleed bubbles into the fuel in the discharge-nozzle passage to break it up into small, easily vaporized droplets. The air pressure at the carburetor inlet is transmitted to the float chamber through passages not shown in the figure. This keeps the pressure on the fuel ahead of the main jet equal to the air pressure ahead of the venturi.

Mixture Control.—The manual mixture control (Fig. 69) consists of a needle that may be moved into the mixture-control needle seat to restrict the fuel flow and lean out the fuel-air mixture. A small altitude metering jet at the left permits some fuel to flow to the main jet even when the mixture-control needle is fully depressed at altitude.

Many Stromberg carburetors make use of a "back-suction" type of mixture control. A device of this sort may be used to reduce the basic metering head and partly vent the float chamber to the suction at the throat of the venturi. This is generally accomplished by placing a fixed air bleed in the passage that transmits the air pressure ahead of the venturi to the float chamber. At a point between the air bleed and the float chamber a second passage may be drilled to the throat of the venturi. A slot of variable width placed in this passage may be closed off completely for full-rich mixtures or partly opened to reduce the pressure in the float chamber and thus lean out the mixture.

Idle System.—The diagram at the right of Fig. 69 shows the idle system in operation. It is much like that described under modifications of the simple carburetor, for it makes use of the low-pressure region at the edge of the closed throttle valve to provide a high suction for fuel metering.

Note that an air bleed is provided to help vaporize the fuel. In some carburetors, this air bleed is made variable to provide a means of adjusting the idle mixture.

Power Enrichment.—In Stromberg float-type carburetors the power-enrichment device is called an *economizer*, for it closes off part of the fuel flow to give economical mixtures in the cruising

range. The device shown in Fig. 69 is linked to the throttle. It remains closed until the throttle has been opened to the point at which mixture enrichment should begin. It permits continuously richer mixtures until the valve has opened far enough to constitute less of a restriction than the economizer jet. At greater throttle openings, the fuel is metered by the main and economizer jets operating in parallel.

Accelerating Pump.—The accelerating pump shown in Fig. 69 consists of a cylinder, which is connected to the throttle, and a piston. Fuel is trapped in the cylinder when it is raised to the idle position by the throttle linkage. A spring under the piston in the cylinder allows it to be depressed by the pressure on the trapped fuel if the throttle is opened suddenly. Depression of the piston opens the pump valve to permit the trapped fuel to be driven off through the accelerating-pump discharge nozzle.

Shortcomings of the Float-type Carburetor.—Although the float-type carburetor has been widely used, operations in high-performance aircraft have shown that it is seriously deficient in a number of important respects. One of these is the limitation imposed on maneuvers by the float method of fuel-pressure regulation. One could hardly expect the float control to give satisfactory fuel metering in upside-down flight, in steep banks, under conditions of negative acceleration such as occur when the nose is dropped to begin a steep dive, or in any of numerous other attitudes and maneuvers. Rough engine operation, backfiring, and possibly stoppage of the engine will invariably occur under certain conditions.

Another difficulty is throttle icing. The latent heat of vaporization of the fuel causes a temperature drop of about 40°F between the fuel discharge nozzle and the throttle valve. If the inlet air temperature is much below 80°F and contains an appreciable amount of water vapor, ice is almost certain to form on the throttle valves of the larger engines. There are other aspects of the icing problem which will be discussed in Chap. XIX, but this is probably the most important.

A third shortcoming of the usual float-type carburetor is its lack of altitude compensation. As pointed out under Effect of Altitude, the fuel-air mixture tends to become increasingly rich during a climb. Proper manipulation of the manual mixture control will offset this effect, but it represents only a stopgap

solution. The pilot has so many other details to attend to that he should not be unnecessarily burdened. In some carburetors the difficulty has been corrected by the addition of an automatic-mixture-control unit.

THE HOLLEY CARBURETOR

The Holley type aircraft carburetor shown in Fig. 70 was first introduced in 1935. It differs from previous types in two important respects: (1) A diaphragm type of fuel-pressure regulator is

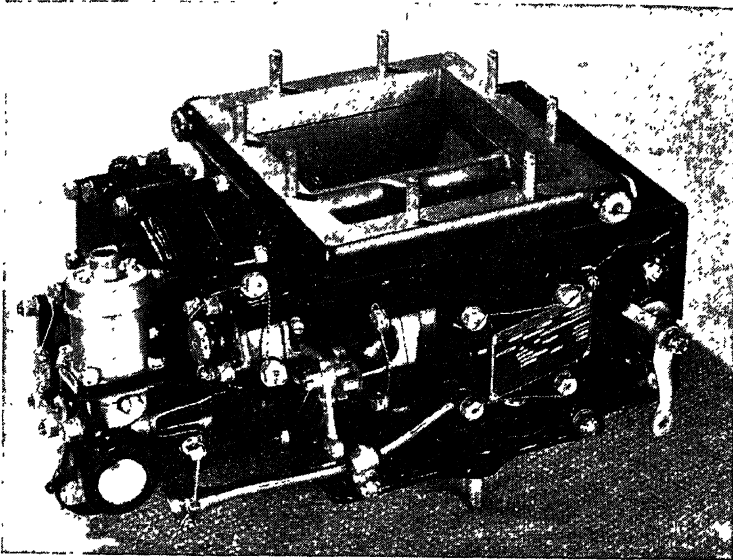

FIG. 70.—Holley model *F* carburetor. (Holley Carburetor Co.)

used to replace the constant-level float chamber. (2) A variable instead of a fixed venturi is used, which, in turn, necessitates a variable restriction in the main fuel-metering passage. All models of the Holley carburetor up to and including model *F* are essentially similar so that the discussion in the following paragraphs will be devoted primarily to model *F*.

Diaphragm Mechanism.—Two synthetic-rubber diaphragms are used to close off the ends of a short hollow cylinder, as shown in Fig. 71. The center of each diaphragm is connected to a valve at the fuel inlet opening to the chamber. When fuel enters the chamber between the two diaphragms, the hydrostatic pressure tends to force them apart. The linkage connected to the dia-

phragms acts to close the valve at the inlet. When the engine is running, suction from the fuel discharge nozzle is transmitted

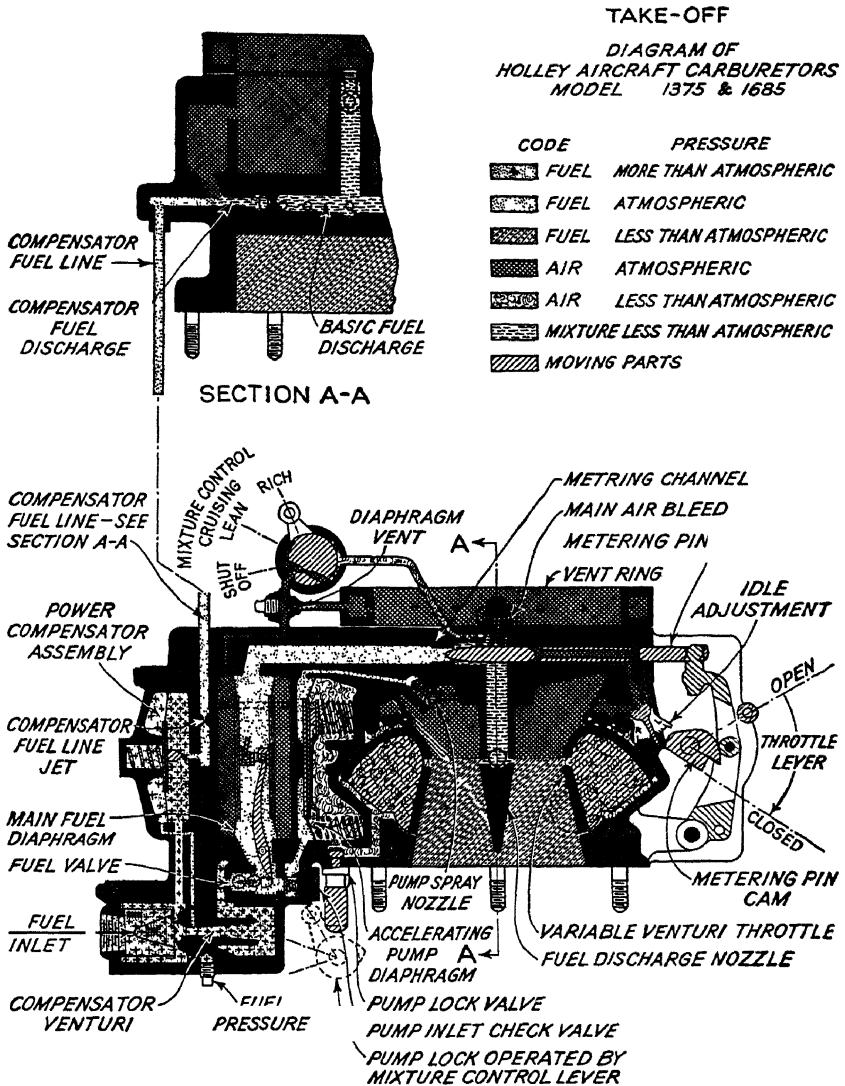

Fig. 71.—Schematic diagram of a Holley model F carburetor. (Holley Carburetor Co.)

back through the fuel-metering channel to the top of the space between the two diaphragms. It decreases the pressure there and causes the fuel level to rise, fill the passage to the discharge

nozzles, and set up a flow of fuel through the carburetor. As a result of the suction imposed at the discharge nozzle, the diaphragm chamber and the fuel passage leading from it are always filled with fuel during operation. Because of the symmetrical arrangement of the diaphragms and the linkage that they operate, the metering characteristics of the carburetor are not appreciably affected by flight attitude or maneuvers.

The Main Metering System.—The walls of the venturi used to meter the air also serve as the throttle. The venturi passage is rectangular in cross section instead of having the conventional circular shape. The front and rear walls of this venturi are contoured sectors of cylinders and have parallel axes. They are geared together so that they rotate toward or away from each other to vary the throat area of the venturi. Figure 71 gives an end view of these throttles (see also Fig. 72).

A cam geared to the throttle operates a large metering pin, or needle. Movement of the throttle is accompanied by movement of this pin, into or out of a restriction in the fuel passage that leads from the diaphragm chamber to the discharge nozzles. The contours of both the cam and the pin are so adjusted that the area of the venturi passage through which the air flows bears a relation to the area of the restriction in the fuel passage through which the fuel flows such that the fuel-air ratio obtained as a result of the metering of the two restrictions is practically constant throughout the operating range. That is, the fixed air venturi and fixed main jet of the simple carburetor are replaced by a variable air venturi and variable main jet, with the variation in the two so proportioned that their resultant metering characteristics are similar to those of the simple carburetor.

The fuel is discharged into the air stream from a nozzle bar located between the two throttle sectors. The actual discharge openings are directed into the throat of the venturi formed by the throttle so that they are open to the lowest static pressure in the carburetor. The difference between the pressure at the nozzles and that in the regulator chamber is the fuel-metering head.

As in the modified simple carburetor, an air bleed is installed in the fuel passage leading to the fuel discharge nozzle to help vaporize the fuel after it enters the air stream.

Idle System.—Because a high suction acts directly on the nozzle bar when the throttles are nearly closed, the Holley type

carburetor tends to run too rich instead of too lean in the idle range. An auxiliary air bleed is located in the main metering pin to offset this. The air-bleed opening from the pin into the fuel passage is so located in the shank of the metering pin that the bleed is effective only at nearly closed throttle; *i.e.*, it is covered up as soon as the metering pin has been withdrawn appreciably from the full-closed throttle position (see Fig. 71). A restriction is placed in the idle-air-bleed passage, which may be varied to obtain the desired adjustment. This variable idle air bleed is controlled by a small arm, which is easily accessible on the right front side of the carburetor.

Power Enrichment.—Mixture enrichment in the high-power range is provided by a *power compensator*. This is an auxiliary metering system that is controlled by a spring-loaded diaphragm-operated needle valve. Figure 71 shows that the fuel entering the carburetor flows through a venturi before it reaches the main diaphragm chamber. The pressure ahead of this venturi is transmitted to one side of the compensator diaphragm, and the pressure in the throat to the other. When the fuel flow becomes high, the pressure differential acting on the diaphragm lifts the compensator needle off its seat and permits fuel to flow to the discharge nozzles located at one end of the nozzle bar. The higher the pressure differential across the venturi in the fuel-inlet passage, the farther the compensator needle is lifted from its seat and the greater the mixture enrichment.

The fuel-supply pressure to the carburetor will affect the rate of fuel discharge of the carburetor only in the high-power, or compensator, range because it is only in this range that the fuel-supply pressure is transmitted to the fuel-metering orifices. The fuel-supply pressure for this type of carburetor should be 6 to 7 psi. A change in fuel-supply pressure of 1 psi will affect the mixture ratio at take-off by about 2 per cent.

Manual Mixture Control.—A manual mixture control of the back-suction type is provided by an air-bleed system that controls the air pressure acting on the outer faces of the regulator diaphragms. This region behind the diaphragm is vented, through a small air bleed called the *diaphragm vent*, to the air pressure existing at the carburetor entrance so that, for full-rich operation, the pressure on the fuel in the diaphragm chamber, that is, ahead of the metering needle, is equal to the air pressure

ahead of the throttles. A second air bleed connected to the main discharge nozzles may also act on this region. A variable restriction is placed in this air-bleed line to provide mixture control. When the mixture control is completely closed off, the air pressure on the outside of the regulator diaphragms is that of the air at the entrance to the carburetor. The full metering head acts on the fuel, and the mixture will be full rich. When the restriction is opened somewhat to the part-lean position, the pressure behind the regulator diaphragms is reduced. This causes them to maintain a lower fuel pressure, which, in turn, reduces the pressure drop across the restriction in the main metering channel and thus reduces the fuel flow. If this variable air bleed is opened completely, the pressure behind the regulator diaphragms will become equal to that at the fuel discharge nozzle; the fuel-metering head will drop to zero; and the flow of fuel will cease. This provides a convenient way to stop the engine.

Accelerating Pump.—The accelerating pump consists of a spring-loaded diaphragm, one side of which is open to the suction existing below the throttles while the other is connected through a check valve to the fuel in the regulator chamber. During an idle when the throttle is closed or nearly closed, the suction of the throttle side of the diaphragm causes it to be drawn back so that the chamber on the other side fills with fuel. If the throttle is suddenly opened, the suction is broken and the springs force the diaphragm inward to put the trapped fuel under pressure. Prevented from returning to the regulator chamber by the check valve, the fuel is forced into the air stream through a spray nozzle connected to the accelerating pump.

The passage leading from the low-pressure area behind the throttles to the throttle side of the accelerating pump is provided with a shutoff valve operated by a cam connected to the mixture control. When the latter is moved to the cutoff position, the cam closes this valve, thus maintaining the suction behind the pump diaphragm and storing fuel in the accelerating pump. This fuel acts as a priming charge when the engine is started again. Moving the mixture control from cutoff to full rich serves to release the suction behind the diaphragm and forces the fuel into the engine induction system. This method of priming will be effective for several hours after an engine has been

stopped. Note that it is impossible to flood a stopped engine by pumping the throttle with this type of accelerating pump.

Altitude Compensation.—It happens that this type of carburetor has a certain amount of inherent altitude compensation owing to the fact that, unlike the float-type carburetor, it normally operates at suction of more than 3 in. Hg at the discharge nozzle. That is, it operates out at the right end of Fig. 68. This has two effects. One is that, as the air flow to an engine falls off with increase in altitude, the operating point tends to move to the left to give a leaner fuel-air ratio. This partly compensates for the reduced air density. An even greater factor is the volatility of the fuel. At the reduced pressures existing in the discharge nozzle the fuel tends to boil. The rate of boiling increases with altitude to the extent that boiling takes place even back in the diaphragm chamber. The large amounts of vapor that must be handled by the fuel passages tend to lean out the mixture considerably.

Load Compensation.—A point that should be noted in connection with the matter of altitude compensation is *load compensation*. Carburetors are generally made to give the proper mixture if the power is varied along a propeller-load curve. If the throttle is left fixed, however, and the rpm is varied, the mixture should remain unchanged. If it does, the carburetor is said to have good load compensation. It can be seen from Fig. 68 that the load compensation of this carburetor is inherently poor, for a reduction in air flow at a fixed throttle opening would result in leaner mixtures. This characteristic is undesirable for operation with variable-pitch propellers.

Holley Model H Carburetor.—The Holley Model *H* carburetor is essentially similar to model *F* described above except for the addition of a stabilizer valve designed to provide both load and altitude compensation, the addition of a vapor separator, revisions in the idle system, and the addition of a power mixture valve. Figure 72 shows a diagram of the model *H* carburetor. The sensitive portion of the stabilizer valve consists of sealed capsules filled with air so that a change in either air temperature or pressure will cause the capsules to expand or contract. The chamber in which the capsules are enclosed is vented to the fuel discharge nozzle. The capsules control a restriction in a passage leading to the space behind the main fuel diaphragms so that

they may act in parallel with the manual mixture control to decrease the metering head. The proportions of the stabilizer-valve parts are so adjusted that it automatically maintains a constant fuel-air ratio independent of changes in load or air density.

The vapor separator depends on a float-controlled valve placed at the top of the main diaphragm chamber. Accumula-

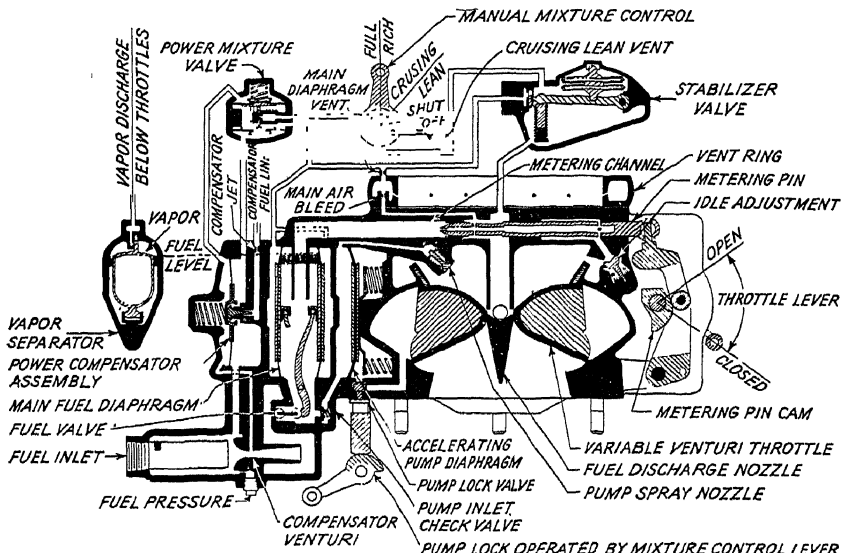

Fig. 72.—Schematic diagram of a Holley model H carburetor. (Holley Carburetor Co.)

tion of vapor in the chamber lowers the fuel level. This causes the float to drop and permits the vapor to escape through a passage that discharges below the throttles.

The power mixture valve is controlled by the pressure differential between the inlet and the throat of the compensator venturi at the fuel inlet. When the fuel flow becomes high enough to cause the compensator to begin to open, the power mixture valve, acting under the same pressure differential, closes off the passage between the manual mixture control and the space behind the main fuel diaphragms. This gives full-rich mixtures in the high-power range regardless of the position of the manual mixture control.

The model *H* idle system depends on a small hole in the tip of the metering pin to restrict the fuel flow under idling conditions. A variable air bleed similar to that in the model *F* carburetor permits idle mixture adjustment.

Adjustment.—In spite of the seemingly complicated nature of its metering system, the Holley type carburetor is light, simple, and rugged in construction. It may easily be adjusted to obtain the setting desired if the adjustments are small. To enrich the mixture in the compensator (high-power) range, it is necessary only to remove shims from behind the spring that loads the compensator needle. Idle adjustment is obtained as mentioned above. The basic curve may be enriched or leaned out by changing the relationship of the metering pin and the throttles. Such changes cannot be made indiscriminately: they must be made in proper sequence by one thoroughly familiar with the work.

STROMBERG INJECTION CARBURETOR

The Stromberg injection, or pressure-type, carburetor was introduced in 1939. Although its external appearance is somewhat like that of earlier Stromberg carburetors, it is even more unlike them internally and in its operation than is the Holley type. One important feature of the injection carburetor is that it consists of a number of separate units, each of which may be removed, disassembled, reassembled, and tested by itself.

Throttle Body.—The principal part of the carburetor is the throttle body. Upon it are mounted the various units of the metering system. The throttle body generally contains two large venturis. At the base of each of these metering venturis where they will not disturb the metering air flow are located the butterfly throttle valves. A small, or *boost*, venturi is placed ahead of each large main venturi so that the exit of the former is in the low-pressure region in the throat of the latter. Impact tubes, which face toward the entering air stream at the entrance to the large venturi, give the total pressure ahead of the air-metering orifices. The pressure differential between the impact tubes and holes in the throats of the small venturi is proportional to, but many times greater than, the pressure drop across the main venturi, thus greatly increasing the available metering

head for a given pressure drop in the air stream through the carburetor.

Regulator Unit.—A diaphragm type of fuel-pressure regulator is used. The two main diaphragms are the *air diaphragm* and the *fuel diaphragm*. One side of the former is exposed to the pressure on the impact tubes and the other to the suction in the boost venturi. The fuel diaphragm is exposed on one side to the fuel pressure ahead of the fuel-metering jets and on the other to the metered fuel below the jets. The two diaphragms are directly connected so that the air-metering head is always balanced by the fuel-metering head. These diaphragms control the fuel-inlet valve at the entrance to the regulator unit. If the fuel-metering head tends to drop below the air-metering head, the diaphragms deflect under the pressure unbalance, open the inlet valve, and allow an increase in fuel pressure and hence in flow. A study of the air and fuel passages shown in Fig. 73 should prove to be worth while. Notice that diaphragm-type seals are used around the spindle connecting the fuel and air diaphragms. The pressure acting on the seals at the ends is balanced by connecting

An important feature of this regulator is that it makes it possible to control the pressure drop across the fuel jets and yet keep pressures below the jets much greater than atmospheric. This permits the use of pressure on the discharge nozzle and greatly reduces the tendency toward the formation of vapor bubbles.

Fuel-control Unit.—The fuel-control unit shown in Fig. 73 is similar in its metering characteristics to its counterpart in the float-type carburetor. In the cruising range, all the fuel is metered by the cruise jet.

To enrich the mixture in the high-power range, a power-enrichment jet is placed in parallel with the cruise jet. Flow through this jet is controlled by a spring-loaded valve, which is operated by another diaphragm. The diaphragm begins to lift the valve off its seat when the fuel diaphragm-pressure differential becomes great enough at high powers. The valve continues to lift by an amount that increases with air flow, thus enriching the mixture. The difference between the pressure of the metered and unmetered fuel is used to operate this diaphragm and thus control the amount of power enrichment until the valve has

opened so far that it becomes much less of a restriction than the power-enrichment metering jet.

The idle mixture is enriched by the idle spring, which holds the fuel-inlet valve to the fuel-pressure regulator slightly off its seat. This permits fuel to flow through the regulator. The enrichment made in this way is greater than necessary. The idle mixture is then leaned out by the idle needle, which is linked to the throttle. At small throttle openings, it controls a restriction in the main fuel passage. As the throttle is opened farther, however, the idle needle is withdrawn very rapidly and so has no effect on fuel flow at powers above an idle.

Discharge Nozzle.—An unusual departure from previous carburetor practice is found in the use of a pressure-type nozzle to spray the fuel into the air stream to break the gasoline up into fine, easily vaporized particles. No air bleed in the fuel passage is used; yet dispersion and vaporization of the fuel are at least as good with this carburetor as in former types with air bleeds. A spring-loaded check valve is placed in the fuel passage to the nozzle bar to prevent a flow of fuel through the latter until the pressure available rises to about 5 psi.

Accelerating Pump.—The Stromberg pressure-type carburetor makes use of a double-diaphragm-type accelerating pump located in the carburetor adaptor (see Fig. 73). One side of the right diaphragm is vented to the region just below the throttle. The suction developed at points of nearly closed throttle is transmitted to the right diaphragm and causes it to draw a charge of fuel through the pump control bleeds into the space between the two diaphragms. When the throttle is opened, the suction on the back of the right diaphragm is broken and the fuel in the chamber is forced against the left diaphragm, causing it to open the accelerating-pump valve. This permits fuel to discharge through the accelerating-pump spray nozzle. At the same time, fuel escapes from the space between the two diaphragms. This relieves the pressure on the left diaphragm and enables the valve to close.

Manual Mixture Control.—Manual mixture control is obtained by means of a disk that may be moved to close off the passage from the cruise jet, thus restricting the fuel flow. This mixture control is mainly effective in the cruising range: at take-off power the power-enrichment needle has opened so far that the reduction

in flow through the automatic rich jet has a negligible effect. The manual mixture control is operated by a lever on the outside of the carburetor. This lever is mounted on a notched disk. A spring-loaded pin tends to move into the notches and lock the disk in position. The arrangement is such that the pilot can move the mixture-control lever in the cockpit and feel the control tend to lock in each of the several positions, which are, respectively, *cutoff*, automatic lean (*auto-lean*), automatic rich (*auto-rich*), and *full rich*. With the manual mixture control set in any given position, the carburetor should deliver exactly the same fuel-air ratio regardless of altitude if the horsepower is kept constant. It does not succeed in doing this exactly under all conditions because of the many variables involved, but the automatic mixture control described below enables it to approach this ideal.

Automatic Mixture Control.—The pilot should be able to climb or descend rapidly without needing to pay any attention to the manual mixture control. That is, he should have a carburetor whose metering characteristics are unaffected by altitude. With any given mixture-control setting, the carburetor should maintain a constant fuel-air mixture ratio regardless of carburetor inlet air density. The injection carburetor incorporates an automatic-mixture-control unit that is intended to do this. The sensitive element in the unit is a syphon bellows, the bellows portion of which is filled with oil to dampen vibration. At the top of the bellows is a chamber filled with nitrogen, as the inside of the unit is sealed off (see Fig. 73). The outside is open to atmospheric air at carburetor air inlet pressure. A decrease in atmospheric air pressure will cause the bellows to elongate owing to the higher pressure inside. An increase in carburetor air temperature will cause the unit to increase in temperature, and the nitrogen within the bellows will expand and again will force it to elongate. Thus the unit is sensitive to air density, for it is affected by both temperature and pressure.

The bellows operates a specially contoured needle that forms a variable restriction in the air passage from the impact tubes to the air diaphragm. This restriction would not be effective if it were not for a small bleed passage connecting both sides of the air diaphragm. The air bleed sets up a continuous flow of air past the automatic-mixture-control needle. When the

bellows expands, it reduces the passage area for this flow, thus reducing the pressure on the impact-tube side of the air diaphragm. The available metering head and hence the fuel flow are thus reduced, and the latter is kept proportional to the mass of air flowing.

Figure 68 shows typical curves obtained with an injection carburetor. The upper curve is that obtained with the manual mixture control in the full-rich position, while the lower line is that obtained with the manual mixture control in automatic lean. The automatic mixture control acts to preserve the same fuel-air weight relationship regardless of inlet air density throughout the operating range.

CARBURETOR SETTING AND TESTING

Metering Problems.—From the above discussion, it is evident that carburetors are complicated mechanisms. The relationship between fuel flow and air flow is a complex one, dependent upon many variables. For example, two metering needles having contours identical within a few ten-thousandths of an inch will give noticeably different metering characteristics when installed in the same carburetor. The lost motion and play in any linkage system is certain to introduce errors. Diaphragms, calibrated springs, and jets cannot be made absolutely identical. The cumulative effect of these items is such that it is not possible to make carburetor parts in production, assemble them, and obtain a carburetor which will give the desired fuel-air ratio throughout the operating range within 2 or 3 per cent. Instead, it has been found best to test and adjust each carburetor when it is assembled new and each time after it is disassembled.

Test Methods.—The final test of any carburetor is the way it meters when installed on an engine. Each carburetor may be adjusted, or *set*, by actual engine testing. Since this has usually proved to be expensive, a technique of flow testing a carburetor without the use of an engine has been developed. This makes use of the fact that the carburetor really meters on air flow: if the proper fuel flow is obtained at the air flow and throttle setting corresponding to a given horsepower, the metering characteristics may be considered satisfactory at that point.

A *master setting* must be obtained first on an engine; *i.e.*, a *master carburetor* must be adjusted to give the proper fuel-air

mixture ratio throughout the operating range. Each production carburetor can be adjusted to meter in the same way as the master carburetor by installing it on the suction side of a blower. The carburetor throttle and the blower controls can be adjusted to give the desired air flow and throttle opening. The latter is usually determined by adjusting the pressure drop across the carburetor to the proper value.

The metering characteristics are usually checked along a propeller-load curve. The air flow and carburetor drop are adjusted to the proper value, and the fuel flow is measured. The process is repeated at intervals along the curve. If the curve of fuel-air ratio plotted against air flow does not fall within a few per cent of that obtained with the master carburetor at all points, readjustments must be made in the production carburetor.

The Carburetor Air Box.—A specialized test stand, called an *air box*, is used for the carburetor test work described above. Air is induced through a metering orifice and ducted to the carburetor. The mixture of gasoline and air then flows from the carburetor into a large tank, which serves both as a separator and as a surge tank to dampen out pulsations from the air suction pump, which is usually a Roots blower. Since the gasoline is still largely in the liquid state when it reaches this tank, much of it collects in the bottom. Air and gasoline vapor are drawn off from the tank by the suction blower and discharged either to atmosphere or to the base of a cooling tower. A battery of water sprays in the cooling tower chills the mixture and causes some fuel to condense out. Gasoline is pumped out of the bottom of the large surge tank and piped to a storage tank. Water and gasoline are pumped from the base of the cooling tower and thence to a separator. Suitable valves and control equipment are, of course, installed where needed.

The air box has many advantages as a means for setting carburetors. Installations can be made easily and quickly. Curves can be run off without danger to the engine—a lean mixture at take-off air flows will not “score a cylinder” in the suction blowers. Setting changes can be made without difficulty. Furthermore, an engine together with the necessary test equipment is a complex affair to handle. Not nearly so many gauges and instruments must be watched, none of the difficulties likely to occur during engine operation is present, and the time required

to run a given curve is much less if the carburetor is tested on an air box instead of on an engine.

PRIMING SYSTEMS

Aircraft Requirements.—Aircraft engines, like automobile engines, are sometimes difficult to start. While the power needed to turn over a 50- or 100-hp automobile engine is not great, that required for an aircraft engine of 1,000 or 2,000 horsepower is large. To reduce to a minimum the amount of motoring over that is necessary to start an engine, some method of introducing gasoline into the induction system prior to an attempt at starting is ordinarily provided so that a charge of gasoline and air is immediately available.

Special Primers.—The engine may be primed with the carburetor or with an auxiliary system of one or more small tubes connected to jets in the intake passages. In radial engines, these jets may be placed in the intake port of the cylinder itself, in the diffuser or blower section, or in the carburetor adaptor. Fuel is supplied to the jets by a simple plunger-type manually operated primer, by a small electrically driven pump, or through an electrically operated valve connected to the carburetor.

Float-type Carburetors.—Engines equipped with float-type carburetors fitted with accelerating pumps operated by the throttle may be primed by moving the throttle control back and forth while maintaining fuel pressure at the carburetor. This pumps gasoline through the accelerating jets into the induction system.

Holley Type Carburetors.—With the Holley type carburetor the accelerating-pump diaphragm holds a charge of fuel for many hours after a stop. This fuel is released when the mixture control is moved out of the cutoff position. A second attempt or any attempt made after a prolonged shutdown requires an auxiliary priming system such as that mentioned above.

Stromberg Injection Carburetors.—Engines fitted with Stromberg injection carburetors will be primed if a fuel pressure of 5 to 10 psi is maintained on the carburetor for a short time. Fuel passed through the fuel-control unit by the idle spring will be injected through the carburetor discharge nozzle. Priming engines in this way is not considered good practice, however, for too much fuel is likely to be injected.

CHAPTER VIII

IGNITION

The ignition system is one of the many units of an aircraft engine without which it cannot function. Just how important it is from the maintenance standpoint is indicated by the fact that approximately half of all air-line-schedule interruptions due to mechanical reasons of any kind have been chargeable to power-plant ignition equipment; or, to put it differently, 80 to 90 per cent of the delays caused by the engine itself have been due to ignition trouble.¹

THE IGNITION SPARK

Spark Effectiveness.—The ignition of a fuel-air mixture by an electric spark is not complex from a practical standpoint. All that is necessary is that a spark of sufficient intensity to ignite the compressed charge occur at the right time in every cylinder near the end of each compression stroke. It has been found from tests that increasing the spark intensity over the minimum required for dependable operation results in no particular benefits in the form of increased power or decreased specific fuel consumption.

Spark Gap and Voltage.—The voltage required to jump a spark gap increases with the pressure of the charge between the electrodes and is approximately proportional to the length of the gap. These effects are illustrated in Fig. 74, which shows the effects of imep on the peak voltage occurring across the electrodes of spark plugs with two different spark gaps. This is the voltage required to start the spark. Once current begins to flow, the difference in potential across the gap drops to a much lower

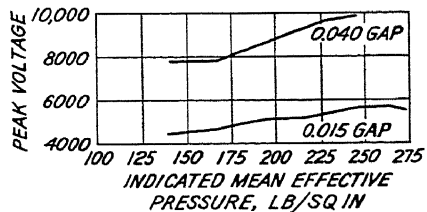

FIG. 74.—Effect of imep and spark gap on the peak voltage required at the spark plug. (Tognola and De Chará, *Automotive Ind.*, vol. 78, 1938.)

value. In practice, a spark of about 6,000 volts across a 0.011- to 0.015-in. gap has been found to give entirely satisfactory results in aircraft engines.

TYPES OF IGNITION SYSTEMS

There are two principal types of ignition system, one depending on a battery as a current source and the other on a magneto. The so-called *battery ignition system* has been used almost universally in automobiles; it was used in the First World War Liberty aircraft engine; and it is now being used in a number of aircraft engines of less than 400 hp. All the larger and many of the smaller aircraft engines make use of magneto ignition systems. Probably the main reason for this is dependability—a magneto ignition system is integral with the engine and has no external battery or wiring to give trouble.

The Battery-coil Ignition System.—The battery ignition system requires a battery to supply current, which flows through a set of breaker points and the primary winding of an induction coil. One side of the secondary winding of the coil is grounded, while the other is connected to the distributor. This contains a shaft rotating at one-half crankshaft speed. The shaft carries the distributor finger, or rotor, which passes over contact points placed at regular intervals around the circumference of the distributor block. Each of these contacts is connected to the center electrode of a spark plug. A current flowing in the primary circuit sets up a strong field in the induction coil. If the breaker points in the primary circuit are suddenly opened, this field collapses, inducing a high-tension current in the secondary winding. Since the breaker points are operated by a cam on the distributor shaft and are timed to open when the distributor finger is passing over one of the contacts in the distributor block, the high-tension current in the secondary winding flows through the distributor to a spark plug, across the spark-plug gap, and into the spark-plug shell, where it is grounded. A condenser is placed across the breaker points to reduce arcing and burning of the points and to make the collapse of the field set up by the primary winding much more abrupt.

Figure 75 is a schematic diagram for a coil ignition system. Note that no special provision is needed for starting, since the battery supplies a good spark whether the engine is turned over

rapidly or not. Although not a direct part of the battery ignition system, it is evident that a generator is also necessary to keep the battery charged.

The Magneto Ignition System.—The magneto ignition system is essentially similar to the battery-coil type except that the battery and coil are replaced by a magneto having a coil built integral with it. In many types the distributor is also made integral with the magneto, giving a compact unit. Figure 76 is a diagram of a magneto ignition system. In the system shown,

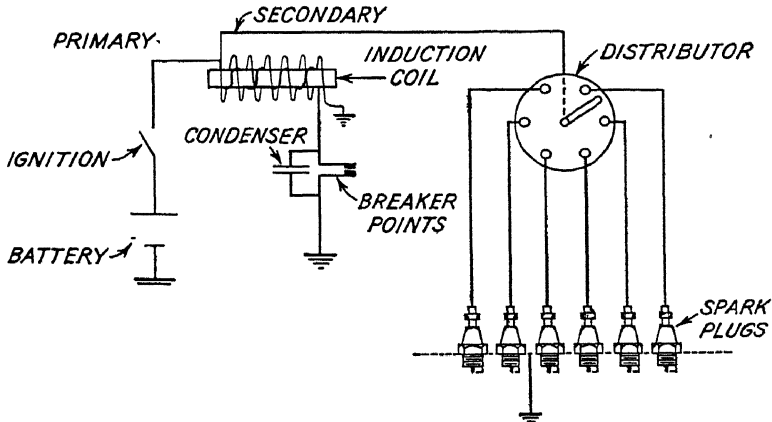

FIG. 75.—Battery-coil ignition system.

two magnetos are used, each having the distributor incorporated under the same housing. The magnetos are of the four-pole type and are for a nine-cylinder radial engine.

Two important differences from the battery-coil system, in addition to the source of current, should be noted. One of these is that some special provision must be made for starting because the magneto rpm is often not great enough at cranking speeds to generate enough voltage to fire the spark plugs. The booster magneto shown in Fig. 76 is one of the methods used to assist in giving a good spark for starting. The two systems differ, too, in the location of the ignition switch, which affords perhaps the quickest method of stopping an engine by interrupting the ignition spark. This was done in the battery ignition system by opening the primary circuit. In the magneto ignition system, it has been found best to ground out the primary circuit; hence, the ignition switch gives a *closed* circuit when in the *off*

position and an *open* circuit in the *on* position. If the primary circuit is grounded out, the usual abrupt collapse of the magnetic field when the breaker points open does not occur, and the voltage induced in the secondary becomes negligible.

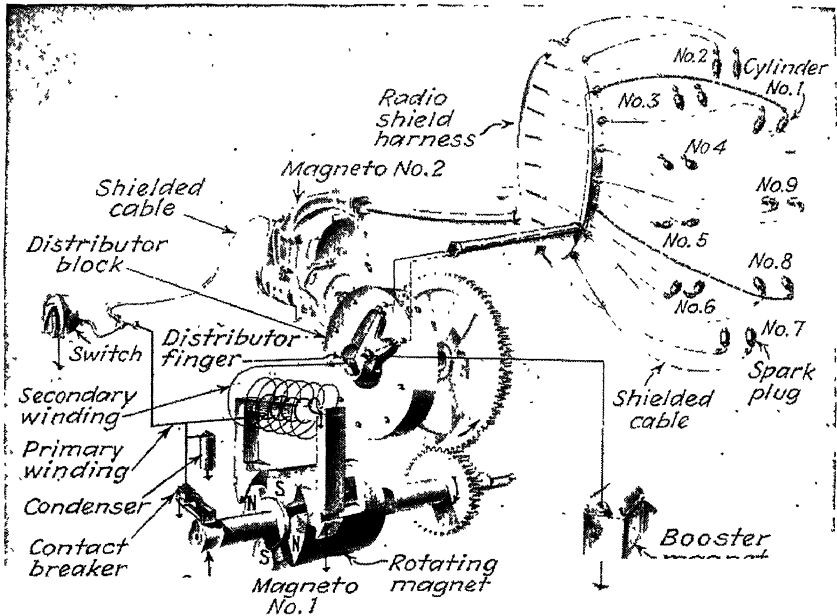

FIG. 76.—Magneto ignition system. (Scintilla Magneto Division, Bendix Aviation Corp.)

THE MAGNETO

The Rotating-coil Magneto.—Magnetos similar to those used in old telephone systems have been used to supply a spark for ignition. These depend upon a coil rotating between the poles of horseshoe permanent magnets. By using many turns of fine wire in the coil, high voltages may be obtained. Current is taken from the coil through slip rings. Because of its relatively large weight, the service problem inherent in the rotating coil and slip rings, and other similar factors, the rotating-coil magneto is seldom used except as a booster magneto.

The Rotating-magnet Magneto.—The rotating-coil magneto has been supplanted by the rotating-magnet type, in which a permanent magnet is rotated between two arms of a horseshoe-shaped soft laminated iron core. Around the core are wrapped

primary and secondary coils. This type of magneto was made possible by an aluminum-cobalt-nickel alloy, which has proved to be a far better material for permanent magnets than anything previously known. The usual rotating magnet may have two, four, or six poles. Figure 76 shows a four-pole magnet rotating between the pole shoes, which are integral with the magneto housing. The magnet sets up a magnetic flux through the pole shoes, their extensions, and the coil core. As the magnet rotates, first a north pole is under the right shoe while a south pole is under the left, then vice versa. Thus the flux in the magnetic circuit tends to reverse its direction as the magnet is turned, the number of reversals per revolution being equal to the number of poles on the rotating permanent magnet. Figure 77 shows a curve for the strength of the magnetic field in the coil core plotted against degrees of rotation of the permanent magnet.

A primary winding consisting of a relatively few turns of heavy wire is wound directly on the soft laminated iron core. Each time the magnetic field, or flux, through the core changes, a current is induced in the primary winding. This current is so strong that it sets up a magnetic field in the opposite direction to that of the collapsing field and tends to prevent its changing. Breaker points located in series with the primary winding, however, are timed to open after a certain delay and interrupt this primary current, thus suddenly removing the resistance it had set up to the reversal of the magnetic field and allowing the latter to reverse abruptly. A condenser is connected across the breaker points to prevent the sudden collapse of the magnetic field from inducing a current in the primary strong enough to arc across the breaker points and burn them. A secondary coil consisting of many turns of fine wire wrapped around the primary coil is cut by the lines of flux of the rapidly changing magnetic field, and a high-tension current is induced. This flows to the distributor and from there to the spark plug.

The process may be seen more clearly from the curves for magnetic flux, primary current, and secondary current shown in Fig. 78. In comparing the curve in Fig. 77 giving the magnetic flux when the primary circuit is continuously open with the curve of magnetic flux in Fig. 78 in which the primary circuit is closed and then abruptly opened, note that the primary current induced by the changing magnetic field considerably

alters the curve for the latter, making its collapse virtually instantaneous when the breaker points are opened. As a result, the voltage induced in the secondary coil becomes very high, setting up a flow of current in the secondary circuit and causing

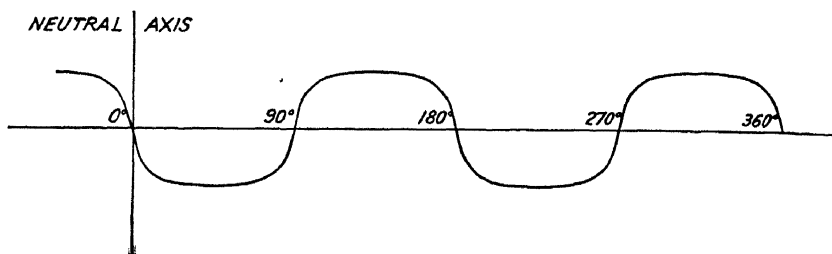

FIG. 77.—Magnetic flux plotted against angle of rotation of the rotating magnet, with no current flowing in the primary or secondary circuits. (*Scintilla Magneto Division, Bendix Aviation Corp.*)

a spark to jump the spark-plug gap in the cylinder. This spark discharge is a transient condition consisting of many oscillations before the voltage drops to a value too low to leap the spark-plug gap. The current induced in the secondary coil sets up a field which, like that of the primary winding, opposes that of the permanent magnet, thus preventing the latter from building

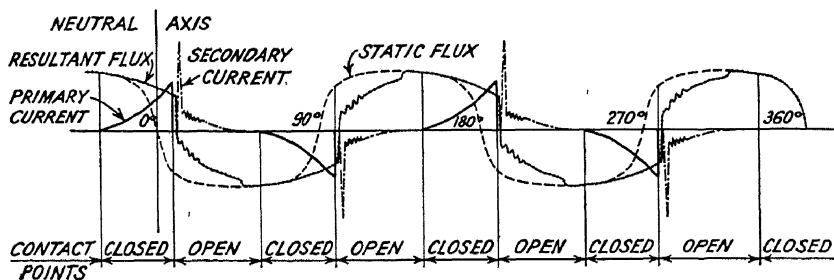

FIG. 78.—Magnetic flux, primary current, and secondary current for normal operation. (*Scintilla Magneto Division, Bendix Aviation Corp.*)

up to its normal strength until the spark discharge ceases (see Fig. 78 for the form of the curves).

High-speed Operation.—The engines for which many of the magnetos were originally designed have since been developed to run at much higher speeds. This in turn has meant that the cycle of events may move too rapidly and a certain amount of overlap occur. At normal speeds, the secondary current will be completely discharged before the breaker points in the primary

circuit close, and hence the field set up by the rotating permanent magnet will be built up to full strength. If a magneto of the original design is run too fast, however, the secondary current will still be flowing when the breaker points close in the primary circuit. When the secondary circuit is finally broken at the spark-plug gap, a current is induced in the primary in a direction opposite to that of the current normally flowing (see Fig. 79).

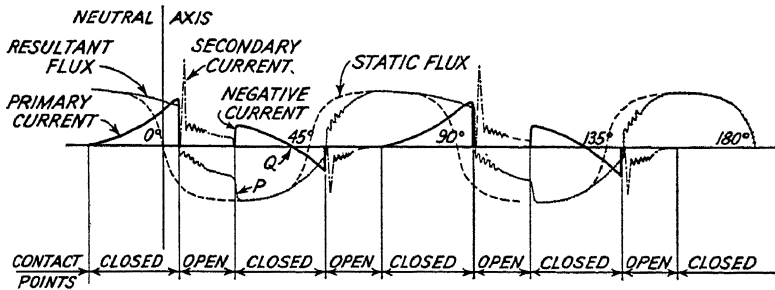

FIG. 79.—Magnetic flux, primary current, and secondary current at high speed with no condenser in the secondary circuit. (*Scintilla Magneto Division, Bendix Aviation Corp.*)

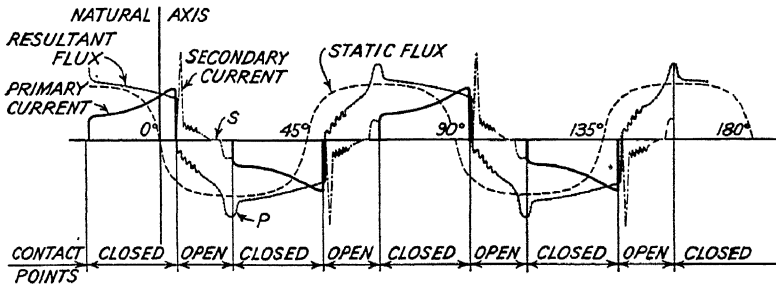

FIG. 80.—Magnetic flux, primary current, and secondary current at high speed with a condenser in the secondary circuit. (*Scintilla Magneto Division, Bendix Aviation Corp.*)

This initial setback of the primary current results in a much weaker magnetic field when the breaker points open next, and a weak current in the secondary, accompanied by a weak spark, results. This condition has been rectified by placing a condenser in series with the secondary circuit. The condenser has little effect on the beginning of the spark discharge but causes the current in the secondary to break off abruptly and reverse itself. This sets up a magnetic field in the other direction and gives the current in the primary circuit a strong "boost" in the desired direction, resulting in a much stronger spark (see Fig. 80).

Frequency of the Spark.—Since a spark is required each time a cylinder is to fire and since a spark is obtained each time a pole of the rotating magnet passes under a pole shoe, *the magneto must be geared to the engine to give the proper number and timing of the sparks.* That is, in a nine-cylinder four-stroke-cycle engine equipped with a magneto having a four-pole rotating magnet, $4\frac{1}{2}$ sparks per revolution would be required, and so the rotating magnet would turn $1\frac{1}{8}$ times per crankshaft revolution. This means that, if the magneto is driven directly from the rear cover of the engine, the accessory drive shaft in the engine should turn $1\frac{1}{8}$ times crankshaft speed.

Magneto Timing.—When a magneto is installed on an engine, No. 1 piston can be set at upper dead center with both valves closed, *i.e.*, at the end of the compression stroke. If a magneto such as that in Fig. 76 is used, it may then be turned so that the distributor rotor is in position to fire No. 1 cylinder. After installing the magneto in this fashion so that it is approximately timed, adjustment may be obtained by rotating the magneto with respect to the engine as the holes in the magneto mounting flange are slotted to permit this rotation. Since the spark occurs when the breaker points open, the setting may be checked by turning the crankshaft backward until the breaker points close on a strip of 0.001-in. steel shim stock, then turning the engine over slowly in the direction of rotation while putting a light tension on the shim stock. When the breaker points begin to open, the shim stock is released. This should be the proper number of degrees before top center as indicated by a timing mark on the reduction driving gear, by a protractor mounted on the tail shaft at the starter pad, or by some such device.

The "Booster."—The magneto will not develop a spark sufficiently strong to fire the spark plug until the engine is turning over at more than 100 rpm. To provide a spark to aid in starting, a *booster coil* connected to a battery or a hand-cranked *booster magneto* is usually provided. The current from this is fed to the distributor rotor, but to a different conductor from that carrying the regular current (see Fig. 76). The *booster electrode* trails the high-tension distributor finger by one segment, thus giving a greatly retarded spark and preventing the engine from "kicking back." An important point which follows from this is that much smoother starting of an engine fitted with a

“booster” can be obtained if the ignition switch is kept in the “off” position while cranking the engine and a retarded spark supplied by the booster.

Impulse Couplings.—To ensure a good spark at cranking speeds the magnetos for many of the smaller engines are fitted with an impulse coupling. Instead of being directly connected to the engine, the rotating magnet is driven through a spring. A ratchet arrangement prevents rotation of the magnet until the engine has turned over 30 or 40 deg., at which point the ratchet is tripped and the spring rotates the magnet rapidly for a part of a revolution, generating a good spark. The couplings are so designed that centrifugal force acts on the ratchet, causing it to be ineffective above about 200 rpm so that a uniform velocity of rotation for the magnet is obtained at higher speeds.

IGNITION HARNESSSES

Ignition Wire.—A wiring system called an *ignition harness* is provided to conduct high-tension current from the distributors to the spark plugs. Since this must conduct electricity at as much as 10,000 volts, enough voltage to jump a $\frac{3}{8}$ -in. air gap, the insulation of the wire used must have a high dielectric strength. No ordinary insulation can withstand such voltages. Most ignition wire now in use has a layer of rubber about $\frac{1}{16}$ in. thick directly over the wire. The rubber is covered by a layer of neoprene about $\frac{1}{32}$ in. thick to protect it from oil or gasoline. The neoprene, in turn, is coated with a layer of lacquer, which greatly increases the dielectric strength of the insulation and protects it from chemical attack.

Ignition Shielding.—The magneto is a form of high-frequency alternator and so sets up radiations that interfere with radio reception in the airplane unless the ignition system is completely incased in a metal cover, or shielding. Practically all modern aircraft engines of large size are equipped with shielded ignition systems.

The shielding of an ignition harness usually consists of a formed or cast thin-walled rigid metal manifold, from which extend short flexible leads to each of the spark plugs. The latter are of metal conduit often lined with neoprene or some such material to prevent chafing of the insulation and to seal the conduit so that moisture cannot leak in. At the outer end of each

lead, a spark-plug "elbow," or "derby," is installed. This has a nut at the end, which can be screwed or otherwise firmly attached to the spark plug. A contact spring inside an insulator of mica, formica, or some such material conducts the high-tension current from the ignition wire down inside the spark plug to the contact point for the center electrode. Thus the ignition system is completely incased in metal.

It should be noted that the use of this radio shielding has an inherent disadvantage in that it increases the capacitance of the harness. That is, the wire on the inside acts as one element of a condenser and the shielding, closely paralleling and insulated from the wire, as the other. Before a spark can be discharged across the spark-plug gap, the harness must be charged with electricity. This tends, among other things, to retard the spark and to place a greater load on the magneto. Further, any weak points in the insulation of the ignition wire will be under electrical stress and may fail, permitting the spark to discharge outside the cylinder, with the result that the plug will not fire.

Harness Service Problems.—If the aircraft ignition harness had to operate only under fair-weather sea-level conditions, it probably would not give the trouble it does. As it is, the harness is responsible for about half the ignition difficulties that have been so troublesome. For one thing, modern radial aircraft engines operate with head temperatures that may be as high as 500°F or higher. This is hard on the insulation and may even cause it to begin to char. Further, wire carrying high-tension currents may be surrounded by a phenomenon called *corona*, which appears as a luminous glow and involves ionization of the surrounding air. The formation of ozone accompanies the phenomenon. Trapped within the shielding, the ozone attacks the rubber insulation and causes serious deterioration. Nitrous oxide is also formed by corona. This combines with oxygen and any water present to form nitrous acid, which attacks the electrical insulation and the metal shielding. The appearance of corona is a function of altitude—the less dense the air, the greater the tendency toward corona.

Altitude operation has another undesirable effect. There are considerable air spaces within the harness shielding. In a descent from high altitudes, the relatively higher pressure of the outside air causes it to flow into these spaces in the harness.

Any oil or grease on the outside of the shielding is also forced in, as well as water if it is raining, and perhaps alcohol or other de-icing fluid that may have been used to clear ice from the propeller. Although harnesses that are supposed to be vapor-tight have been made and tested, none has been made that does not leak a little—especially where attached to the spark plugs. Once within the harness, these fluids begin their work of weakening the insulation. Even in fair weather, moisture may condense in the shielding owing to temperature changes and cause trouble.

At the spark plug itself the problem is particularly acute. Gases and water vapor tend to leak from the combustion chamber up through the spark-plug core into the harness. The contact spring and its insulator form a convenient spot on which these products may deposit. Contact springs may rust and corrode to such an extent that they break. A more common trouble is that a film of moisture containing nitric acid or metallic salts may collect on the contact insulator and form a conducting film to give a *spark over* across the surface of the insulator. If this occurs, a conducting deposit is left in the spark path, which serves to short-circuit the spark plug. Similar effects are given by moisture tending to condense on the insulator after the engine is stopped and has cooled off. When it is started the next time, spark over may occur and cause misfiring of that plug until the insulator is replaced.

There have been a number of attempts to make a harness that would stand up under these operating conditions. The vapor-proof harness, mentioned above, was found to be an improvement but not the solution to the problem. Filled harnesses containing a plastic material to fill the space between the ignition wire and the shielding have been tested. They take care of most of the troubles except those around the spark-plug contactor itself. A third type tested has been the supercharged harness, in which dry air under pressure is supplied to the ignition harness, usually one of the vapor-proof type. Natural leakage, principally at the nut attaching the elbow on the harness to the spark plug, provides circulation of the air in the harness and keeps it clear of moisture, oil, etc. By maintaining the pressure in the harness several pounds above the outside air pressure, the appearance of corona and other high-tension discharge phenomena of altitude flying are reduced. A certain cooling effect

in the vicinity of the spark-plug elbow is also obtained, and leakage through the spark plug core is carried off. Air for such systems can be dried by passing it over a chemical drying agent. One air line has tested supercharged harnesses and claims to have eliminated virtually all their ignition troubles chargeable to the harness.² However, the increased weight, cost, and complication are difficult to justify.

SPARK PLUGS

Spark-plug Construction.—The aircraft-engine spark plug must withstand high temperatures, pressures, and electrical

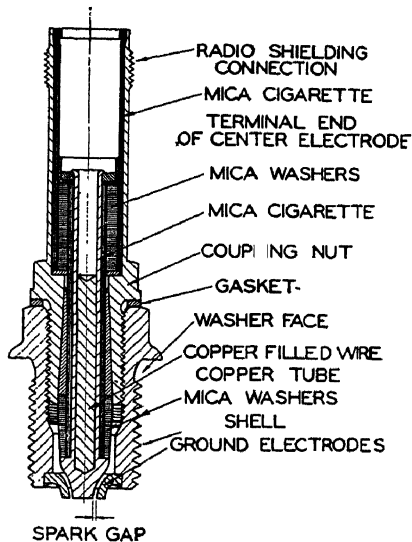

FIG. 81.—Section through a mica spark plug. (Cronstedt, *S.A.E. Trans.*, vol. 35, 1940.)

potentials. The spark plugs that have been developed to meet these severe requirements are much more expensive and complex in construction than their automotive counterparts. Figure 81 shows the construction of a typical plug. Some have fins machined integral with the metal shielding at the upper end as an aid to cooling, much as the fins are machined in an air-cooled cylinder barrel. The center electrode is insulated from the body of the plug by means of mica both in the form of washers and as a tube, or "cigarette," wrapped around the electrode. Many spark plugs are similar to Fig. 81 in construction except that a molded ceramic is used instead of mica. The ground electrodes are welded to the steel shell, which is screwed into the cylinder head. The plug may be partly disassembled for cleaning of the electrodes by removing the inner portion, marked *coupling nut* in the figure, from the outer shell.

Types of Insulators.—The primary requisite of the plug is that it fire consistently, regardless of temperature or other operating conditions. This requires unusually good insulation around the center electrode. The insulating material is a much greater

source of trouble than the electrodes. Ceramic insulators such as those used in automobiles were used in aircraft spark plugs during the First World War. But higher operating temperatures and pressures that came into use after the war imposed such severe requirements that ceramics were abandoned and mica came to be used almost universally. About 1940, however, ceramic-insulated spark plugs again began to make their appearance and were found to be at least equal to mica spark plugs in many service tests. The reason for this is that mica is a crystalline material having a definite formula and fixed physical properties which impose well-defined limitations. Ceramics, on the other hand, are mixtures of refractory materials that have been partly fused together by "firing" at a suitable temperature. The severity of operating conditions has increased until now mica is operating at temperatures close to the limit it will withstand. Developments in the field of ceramics have yielded ceramic materials superior to mica for use in spark plugs.

Mechanical Strength.—Since any crack or break in the insulation will permit a high-tension short circuit, both mechanical strength and shock resistance are necessary characteristics of the insulator. In the past, ceramic plugs have been more susceptible to cracking than mica plugs, owing partly to the fact that a single homogeneous ceramic insulator is used instead of the laminated structure used in mica insulators.

Moisture Resistance.—Mica is a hygroscopic crystal and will tend to adsorb moisture from the atmosphere in damp weather. To prevent this, new or reconditioned mica plugs should be kept carefully wrapped in a dry place or baked in an oven before using. Once installed in the engine, however, mica insulation will adsorb moisture while the engine is not running. This is likely to cause "shorting" and misfiring of the plug when the engine is started, although, once the engine is warmed up, any moisture present will be driven off. Moisture films on the surface of the mica may be wiped or blown off; but if moisture penetrates between the layers of mica, it can be removed only by baking. Ceramic insulators do not adsorb moisture.

Temperature Requirements.—Spark plugs must operate over a wide range of temperatures. Immediately after starting and when idling, they tend to be "cold." Any oil passing the piston rings and deposited on the plugs may cause *fouling* if they are

not hot enough to burn it off. A cylinder misfiring because of fouled plugs may usually be cleared up by increasing the engine power and *warming up*. At high power, on the other hand, plugs tend to run at temperatures as high as 500°F. The electrodes themselves run much hotter, partly because of the heat of the electric spark and partly because of the high temperatures of combustion in the gases surrounding them. The expansion and contraction of the component parts of the plug accompanying the resultant changes in temperature cause openings to form between the insulator, which has a low coefficient of thermal expansion, and the metal parts of the plug, permitting the entrance of oil, moisture, etc. Worse, the thermal stresses may strain and cause actual breakage of the insulator. This is followed by electrical failure. Mica has a certain amount of water of crystallization, which may be driven off at temperatures above 1000°F. A change in the crystalline structure of the mica and a loss of mechanical strength result.

Effects of Tetraethyl Lead.—Another condition that the spark plug must meet is corrosion due to the lead compounds in the fuel. These form deposits on the insulator that may react with the latter. Mica is not affected, but many ceramics are rapidly attacked by the lead compounds to form a lead glass slag having a low melting temperature. This, in turn, may drip onto the electrodes, fouling the latter and causing the plug to misfire. If corrosion does not occur and extensive lead deposits form, these deposits may foul any type of plug and cause misfiring.

Electrode Erosion.—The electrodes themselves must deliver a spark many times each revolution—each plug firing on the average about 60,000 times per hour of engine operation. The spark tends to erode the electrodes. For this and other reasons, aircraft spark plugs use a number of ground electrodes placed radially around the central one. Any one or any combination of these may take the spark. As the electrodes erode or burn away, the gap clearance increases. If it becomes too great, misfiring at high power will occur. The condition may be aggravated by the formation on the points of lead deposits having a relatively high electrical resistance. At high power, misfiring of one plug in a cylinder equipped with two may result in detonation, with possible damage to the engine as a consequence.

Bench Testing.—To determine whether a spark plug is satisfactory, a number of tests have been developed. The most common, bomb testing, is used as a routine check on all spark plugs after reconditioning. The spark plug is screwed into a chamber to which air under pressure is admitted. High-tension current is supplied to the spark plug. If it fires (or sparks) with 160 psi air pressure in the chamber, it should fire in the cylinder of the engine.

A test run on all new types of plug and in some routine work is that for core leakage. Air under pressure is supplied to the spark plug, and the rate of leakage up through the center of the core is measured. The allowable core leakage for a plug that has been run a few hours may be as much as 2 cc per min at 150 psi.

Pre-ignition Rating.—New types of plug must be engine tested. One important test is called the *pre-ignition rating*. A single-cylinder engine is used, and mixture-control curves are run at a constant speed, the curves being run at successively higher bmep's. At high bmep's the spark plug will become so hot that it acts as a "hot bulb" and ignites the charge. "After-firing" is an indication of pre-ignition of this sort. The pre-ignition rating of a spark plug is expressed in terms of the lowest bmep at which pre-ignition occurs at the test speed. Tests are always run relative to a reference spark plug.

Fouling Tests.—A full-scale engine is used to run fouling tests to see if the spark plug runs hot enough when the engine is idling to keep from fouling under ordinary conditions. Since fouling normally occurs, the tests include a check at a cruising power to determine the length of time required to clear up the fouled plugs. When this is done, a "magneto check" is taken. If a fixed-pitch propeller is used and the throttle left fixed, the engine rpm can be noted with the ignition switch first in the "on" position, then with the switch turned to ground out one magneto, and finally with the other magneto grounded out. The difference in rpm between these conditions should be small. If it is not, one or more plugs are misfiring. The ground wires should be checked by turning the switch momentarily to the "off" position to make certain that the grounds are functioning. This should not be done above cruising speeds because the shock

loads of abruptly stopping and starting the flow of power into the crankshaft are severe and may seriously damage the engine.

Endurance and Service Testing.—Extensive endurance tests run in engines operated at continuous high-power outputs in the laboratory, followed by service tests in the field, are part of the final acceptance test of a new type of plug. A careful record is kept of each plug in the sets tested. The condition and gap are noted and recorded before it is cleaned, and the gap is reset after each period of operation. The frequency of ignition trouble occurring between reconditioning periods and the total service life are measures of the suitability of the plug.

OPERATING TROUBLES

It is not always possible to fix the cause of ignition trouble definitely. If one whole set of plugs is "out," *i.e.*, not firing, the evidence points to the magneto. The ground wire may be shorting out, foreign material may be in the breaker points, an electrical short circuit may be present in one of the coils, or something in the magneto itself is not as it should be. If the missing is intermittent on only a few plugs, the difficulty is probably in either the harness or the spark plugs themselves.

Troubles with the spark plugs are particularly likely to occur at high powers where the resistance of the air gap between the electrodes is high. Conditions are usually aggravated by high temperature. Often when the throttle is opened to give high power, the engine will run smoothly for a minute or so and then begin to misfire intermittently on one or two plugs. An experienced operator will recognize the symptoms and look for the trouble in the spark plugs.

Intermittent missing due to malfunctioning of the breaker points in the magneto will be caused by any oil that might reach them, a faulty condenser, or a faulty coil. A white deposit on the breaker points indicates a bad condenser, while a black deposit indicates fouling by oil. This may occur at any power or speed. The breaker points are usually easily accessible for examination and may be replaced if necessary. The condenser across the points may be replaced easily, and likewise the coil; or the whole magneto may be removed and replaced. In the latter case, the distributor block is usually left connected to the

harness. A crack in the distributor block itself may occur; this, of course, will cause trouble. Moisture that condenses like dew on surfaces that are normally nonconductors is a chronic source of trouble. It is particularly bad in damp weather, although it may occur in clear weather at night or in the early morning. Only a few individual plugs may be affected, or the distributor block may become wet and cause a whole set of plugs to misfire.

High-tension short circuits in the ignition harness may be found with a high-tension testing unit. Faulty spark plugs may be replaced without much trouble as a rule, though it is difficult to determine which plugs are faulty if an exhaust manifold is used. Short individual exhaust stacks make identification of missing spark plugs simple, as the exhaust flames may be watched. Ignition-system trouble shooting is largely a matter of cut and try, but a thorough knowledge of the factors involved is helpful.

References

1. CRONSTEDT, V.: Shortcomings of Mica Insulation for Aviation Spark Plugs, *S.A.E. Trans.*, vol. 35, 1940.
2. SWANSON, C. E.: Supercharged Aircraft Ignition Harnesses, *S.A.E. Trans.*, vol. 36, 1941.

CHAPTER IX

COOLING

Internal-combustion engines are heat engines. Temperatures as high as 5000°F may be developed in their cylinders during the process of combustion. These high temperatures heat the walls of the combustion chamber—the top of the piston, the cylinder barrel and head, and the valve heads. If the piston becomes too hot, lubrication between it and the cylinder wall will break down. In air-cooled engines, experience has shown that cylinder-base temperatures must be kept below about 320°F to prevent failure of cylinder-wall lubrication with resultant scoring of the piston and/or the cylinder. The cylinder-head temperature must be kept below 450 or 500°F to prevent breakdown of valve-stem and rocker-arm lubrication. Further, aluminum alloys lose their strength rapidly with increasing temperature to such an extent that, even if lubrication were not a problem, the temperature of the aluminum cylinder head would have to be kept within reasonable limits to prevent rupture of the material under gas loads which may be as high as 1,000 psi. Another important factor is that, the higher the temperature of the combustion-chamber walls, the greater the tendency toward detonation. In short, the cylinder temperature is a controlling factor and must be kept below a certain allowable maximum.

BASIC HEAT TRANSFER

Elements Involved.—Heat flows from the gases in the combustion chamber to the combustion-chamber walls, through the metal walls, and from them to the coolant. Since the gases in the cylinder are in turbulent motion, their temperature is substantially constant throughout. The same may be said of the coolant in the vicinity of any particular part of the cylinder wall. The heat conductivity of the metal wall itself is relatively high; hence, it offers little resistance to heat flow. The principal obstacles to heat flow are two fluid films, one at the surface

separating the combustion-chamber walls from the gases in the combustion chamber, and the other separating those walls from the coolant. Thus the problem divides itself into two parts, the amount of heat that will be transferred from the gases of combustion to the cylinder head and barrel, and the amount of heat that must be removed from the latter by the coolant. Because of the many variables involved, separate consideration of these parts of the problem greatly simplifies matters.

Heat-transfer Equations.—The heat that will be transferred from a fluid to a surface in contact with it is given by the familiar equation

$$H = hA \Delta T \quad (23)$$

where H = quantity of heat, Btu per sec.

h = heat-transfer coefficient, Btu/(sq ft)(°F)(sec).

A = area of contact, sq ft.

ΔT = temperature difference, °F.

In a given engine, the area effective in heat transfer is fixed. With a given cylinder-head temperature, the temperature difference ΔT between the gases in the combustion chamber and the cylinder head depends on the temperature of the gas in the combustion chamber, which in turn depends on a number of factors, principally fuel-air ratio. The heat-transfer coefficient h depends on the viscosity, density, specific heat, thermal conductivity, and, most important of all, velocity of the fluid. These factors, in turn, depend mainly on engine speed and manifold pressure, *i.e.*, total air flow or power output. Dimensional analysis has been used to investigate the matter qualitatively, and tests have been conducted in accordance with the results of the analyses. These tests have shown very close agreement between theoretically derived equations and actual test results. Although a detailed analysis is quite complex, the more important relations may be deduced from Eq. (23).

HEAT REJECTION TO COMBUSTION-CHAMBER WALLS

Mean Gas Temperature.—Not only does the temperature of the gases in the combustion chamber vary with engine operating conditions, but it also varies widely during a single operating cycle. During the compression stroke, the fuel-air mixture

temperature rises from perhaps 100 to about 600°F. The addition of heat upon combustion causes a rapid temperature rise to about 4500°F. The expansion during the power stroke and during the initial part of the exhaust lowers the gas temperature to about 1700°F. Residual exhaust gas at this temperature is left in the cylinder at the beginning of the intake stroke and mixes with the induced charge, raising its temperature considerably.

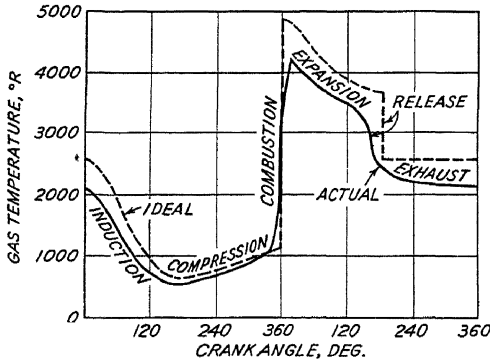

FIG. 82.—Variation in the temperature of the gases in the cylinder for a typical cycle. (*Lichty, Internal Combustion Engines, 1939.*)

The resulting temperature variation throughout the cycle is shown graphically in Fig. 82. From this it is evident that a mean gas temperature must be used. N.A.C.A. tests indicate that the value of this factor is on the order of 1200°F for the cylinder head and 600°F for the cylinder barrel.¹ This is as one would expect, for the cylinder barrel is exposed to the hot gases for only a part of the cycle and then not to the peak temperature. The equation for the flow of heat from the gases in the combustion chamber to the cylinder head thus becomes

$$H = hA_h(T_{gh} - T_h) \quad (24)$$

Similarly, that for the cylinder base is

$$H = hA_b(T_{gb} - T_b) \quad (25)$$

where T_{gh} = mean gas temperature for the cylinder head.

T_{gb} = mean gas temperature for the cylinder base.

T_h = cylinder-head temperature.

T_b = cylinder-base temperature.

A_h = internal area of cylinder head.

A_b = internal area of cylinder barrel.

Effect of Head Temperature.—Cylinder-head temperature is one of the most important factors affecting heat rejection. Referring to the preceding section and Eq. (24), it is evidently the only factor that can be controlled in a given engine operating at a particular power. This theoretical analysis and actual test results indicate that heat rejection to the combustion-chamber walls is directly proportional to the difference between the mean gas temperature and the combustion-chamber-wall temperature.

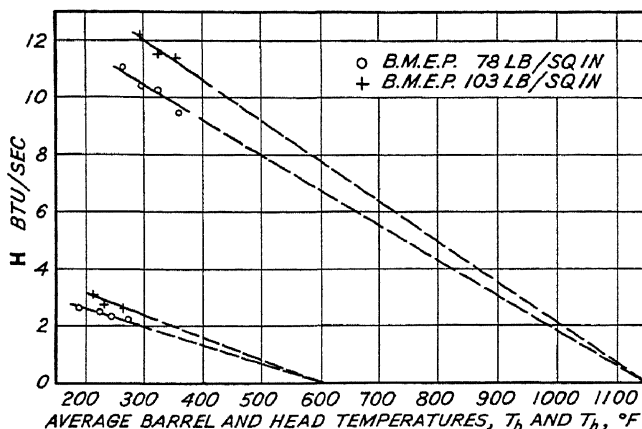

FIG. 83.—Variation of heat transfer from combustion gases to head and barrel with average head and barrel temperatures. Carburetor air temperature, 85°F; spark timing, 26°BTC; air-fuel ratio, 12.3; engine speed, 1,500 rpm. (*Pinkel, N.A.C.A. Tech. Rept. 612, 1938.*)

Since the mean gas temperature runs on the order of 1200°F, a change in cylinder-head temperature from 150 to 500°F would result in a decrease in the effective temperature difference, and hence in heat rejection, of about 35 per cent. This effect is shown in Fig. 83. Note that the heat transfer from the cylinder head according to the extrapolated curve would drop to zero at a head temperature of 1150°F. That is, at the point where the mean gas temperature equals the cylinder-head temperature, heat transfer to the head must be zero.

Effect of Power Output.—The mean gas temperature is not affected much by increase in power at a constant fuel-air ratio. At constant manifold pressure and varying speed the mean gas temperature would certainly remain constant although the power would increase. If the speed is held constant and the manifold pressure is increased, it is quite easy to show that the heat

released per pound of fuel-air mixture at a constant fuel-air ratio is essentially constant. Practically all the heat released by the combustion chamber goes to raise the temperature of the products of combustion. Hence,

$$q_c W = \quad - T_1)$$

from which

$$\frac{q_c W}{W c_v} = \frac{q_c}{c_v} \tag{26}$$

where T_2 = temperature at end of combustion, °R.

T_1 = temperature at beginning of combustion, °R.

W = weight of charge in the combustion chamber, lb.

q_c = heat of combustion, Btu per lb.

c_v = average specific heat of products of combustion.

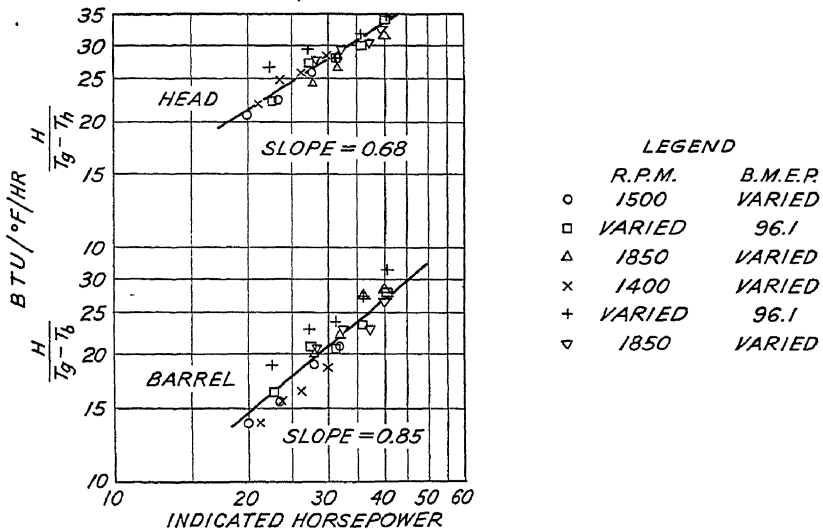

FIG. 84.—Effect of power output on heat rejection to coolant. (Pinkel, N.A.C.A. Tech. Rept. 612, 1938.)

Hence the temperature of the gases in the cylinder is practically independent of the weight of charge present.

Thus, increase in manifold pressure and hence in charge weight will result in no increase in mean gas temperature, for the increased gas weight present will absorb the increased heat released by combustion. The heat-transfer coefficient h , however, is dependent on power, for it is a function of the velocity and density of the gases flowing into, around in, and out of the

cylinder. Increase in either piston speed or gas mass flow will increase the gas velocities and hence the heat-transfer coefficient. This, in turn, increases the engine heat rejection. Figure 84 shows the heat transfer from an air-cooled cylinder plotted against indicated horsepower. Note the fairly wide range of power outputs, speeds, and bme_p's covered. This indicates that engine heat rejection to the coolant may be taken as a function of power without regard to rpm or bme_p.

Effect of Fuel-Air Ratio.—For mixture strengths near best power, fuel-air ratio has little effect on heat rejection. How-

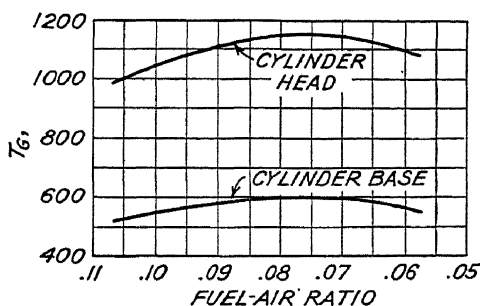

85.—Variation of mean gas temperature with fuel-air ratio. (*Ellerbrock, S.A.B. Trans., Vol. 50, 1942.*)

ever, very rich or very lean mixtures result in flame temperatures considerably lower than normal, which give reduced heat rejection to the coolant. The variation in the gas temperature at the end of combustion with fuel-air ratio was shown in Fig. 36. A somewhat similar curve for mean gas temperature is given in Fig. 85. This curve indicates that a change in fuel-air ratio from 0.075 to 0.105 will result in a decrease in heat rejection of about 25 per cent if the head temperature is 500°F. As will be shown later, this effect is extremely important in air-cooled engines.

HEAT TRANSFER AND COOLANT FLOW

AIR COOLING

Cooling Fins.—Referring again to the basic heat-transfer equation, it is evident that heat transfer will be proportional to the effective area, other factors remaining constant. One of the principal factors in the development of air-cooled engines has been continued improvement in shop technique, which has given greatly increased cooling-fin area through deeper, more

closely spaced fins. The increased heat transfer thus obtained has made possible corresponding increases in specific-power output. Cooling-fin area may be increased by the use of either deeper or more closely spaced fins, or both. Tests indicate that fins may be placed too close together, the optimum performance being given by approximately 13 fins to the inch.² Current engines have cylinder-barrel fins spaced about 10 to the inch. Difficulties inherent in the casting process make cast cylinder-head fin spacings of much more than $4\frac{1}{2}$ to the inch virtually

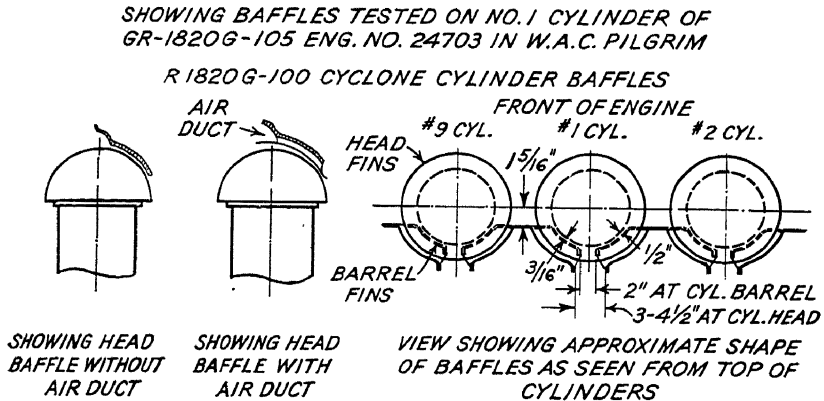

FIG. 86.—Cylinder head and intercylinder baffles used on Wright C9GB engine. (Campbell, *S.A.E. Trans.* vol. 33, 1938.)

impossible under existing methods of manufacture. Fins machined in forged cylinder heads may be spaced more closely, *viz.*, about 6 to the inch. The optimum fin height is limited by the conductivity of the fin material and fin thickness. Practically, fin height is limited both by manufacturing problems and by durability—deep, thin fins are very easily damaged.

Cooling Baffles.—Until about 1933, air-cooled engines were mounted in the airplane so that they might be cooled by the propeller blast. Aside from other disadvantages, this method gave more than adequate cooling of the front portions of the cylinders and too little cooling of the rear. Investigation showed that turbulent air struck the front of the cylinder and circulated between the fins, giving very good cooling. To force the air to contact the surfaces of the fins at the rear of the cylinders, however, it was necessary to make use of baffles, which completely blocked off the space between the cylinders, leaving the space between the fins as the only flow passage (see Fig. 86).

required a pressure differential across them to force the air to flow through the baffle passages, hence the term "pressure baffling" was applied to this method of cooling. Tests showed that very

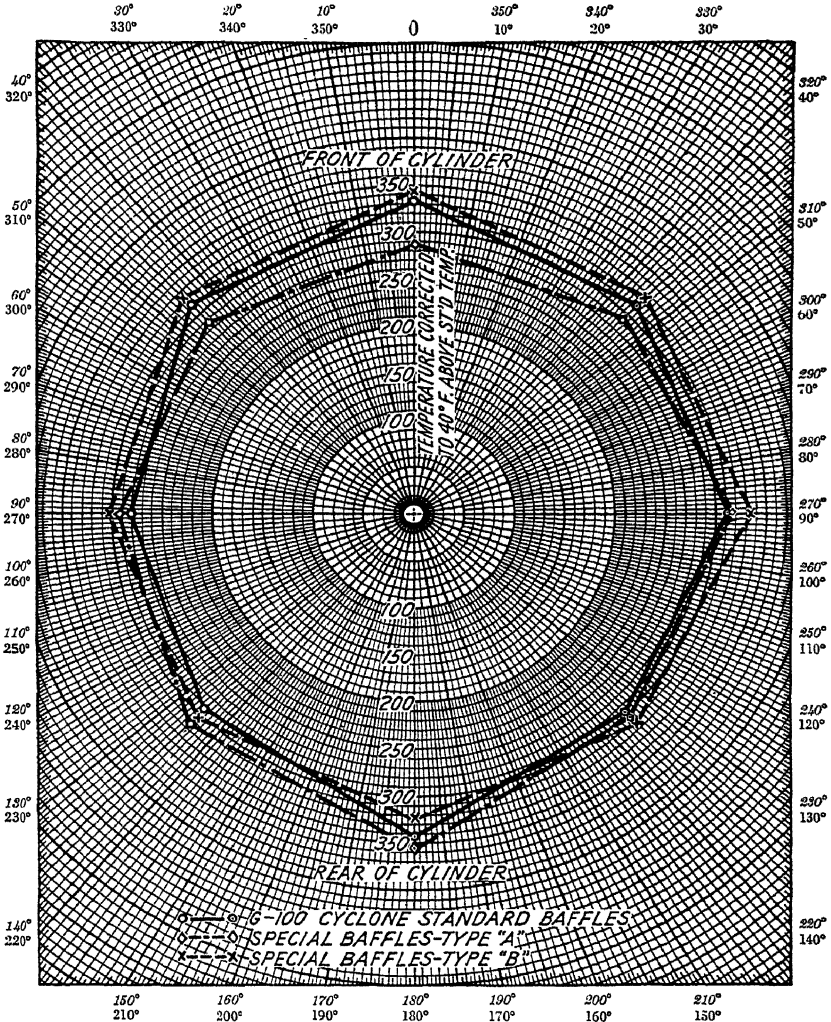

FIG. 87.—Polar plot of upper cylinder-barrel temperature. (Campbell, S.A.E. Trans. vol. 33, 1938.)

uniform cylinder-barrel temperatures could be obtained by properly adjusting the size of the baffle exit opening. Fig. 87 shows a polar plot of cylinder barrel temperature for a typical baffled engine.

Effect of Air Flow on the Heat-transfer Coefficient.—The heat-transfer coefficient h has been found to increase at a rate that is only a little less than linear with increase in the weight of air flowing. More precisely, h varies approximately as the 0.8 power of the mass air flow.³ This applies to many different types of heat-transfer surface, including both baffled and unbaffled cylinders, the air velocity having effect only insofar as it influences the mass flow. As a result, the total heat transfer to the cooling

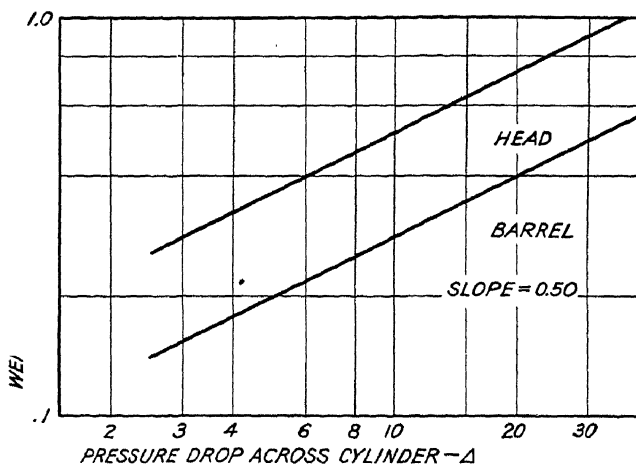

FIG. 88.—Pressure drop across a baffled cylinder as a function of cooling air flow. (Pinkel, N.A.C.A. Tech. Rept. 612, 1938.)

air is not far from being directly proportional to the mass air flow. Thus, doubling the cooling air flow will nearly double the amount of heat carried away if the metal surface temperature is kept constant.

Air Flow over a Baffled Engine.—Extensive tests have shown that air flow through the baffle passages of an air-cooled engine behaves in the same way as air flow through an orifice; *i.e.*, the pressure drop varies as the square of the air flow at a constant air density. The “effective baffle passage area” is the area of a perfect orifice that would give the same air flow at a given pressure differential as the baffled engine. The effect of change in air density with altitude on the air flow through a restriction can be derived from the basic equation for flow through an orifice, as was shown in the chapter on Carburetion.

Since the total heat transfer depends on the mass of air flowing, the mass flow of air through the baffles is important, rather than

the velocity. For a given effective baffle passage flow area, from Eq. (22) the mass air flow G is given by

$$G = K \sqrt{\sigma \Delta p}$$

Therefore, the mass air flow through the restriction formed by the baffles is completely defined by the quantity $\sigma \Delta p$ for a particular installation. This relation is important, for it applies not only to the air flow over air-cooled engines but also to air flow through oil and prestone radiators, induction systems, and intercoolers, in short, through any equipment involving air flow at various altitudes. Figure 88 shows an experimentally determined curve of air weight flow vs. baffle pressure drop for an air-cooled cylinder with a typical set of baffles. Note that the slope of the line on log-log coordinates gives the expected exponent of 2.

LIQUID COOLING

Heat Transfer to Coolant.—The liquid film at the surface of a metal cylinder wall presents far less resistance to the flow of heat than the air film on the surface of the fins of an air-cooled cylinder. In fact, the heat-transfer coefficient between the coolant and the cylinder walls is roughly 100 times as great for the liquid-cooled cylinder as for its air-cooled counterpart. As a result, little difficulty is encountered in keeping a liquid-cooled cylinder head or barrel cool as long as boiling of the coolant does not occur. In some of the higher output engines, however, turbulence-producing devices such as small circumferential ribs on the cylinder barrels may be used to aid in maintaining a uniform temperature distribution. In any event, the combustion chamber-wall temperature is substantially equal to the temperature of the coolant.

Coolant Flow.—Both to keep the cylinder barrel cooler than the head and to minimize the total heat rejection, the coolant is ordinarily admitted to the base of the cylinder barrel, from which it flows up to, over, and out of the head and from there to the radiator. This coolant flow is forced by pumps, which circulate the coolant through the jackets at fairly high velocities. The pumps are of the centrifugal type so that the coolant flow varies with engine rpm. Since the flow is fixed for a particular speed, the increase in heat rejection to the coolant accompanying

an increase in power output at constant rpm is taken care of by an increase in the coolant temperature rise as it flows through the jackets. Thus, maintaining a given cylinder-head temperature at constant rpm and varying power in the liquid-cooled engine involves a change in coolant inlet temperature rather than a change in coolant flow as would be the case in the air-cooled engine.

COOLING CHARACTERISTICS

AIR-COOLED ENGINES

Baffle Pressure Drop-Head Temperature Relationship.—For both laboratory and flight cooling test work, the most convenient quantities to work with are baffle pressure drop and head temperature. They are easily measured and are really the ultimately limiting quantities. Cylinder-base temperatures, while just as important as head temperatures, are generally less likely to be excessive. Further, they will generally bear a fairly close relationship to head temperature for a given installation. Baffle pressure drop is an index both of the cooling air flow over the engine and of the pressure built up by the fan action of the propeller and the forward speed of flight.

The relation between baffle pressure drop and cylinder-head temperature for a constant power output is important. As was shown in Fig. 83, the heat rejection to the coolant falls off linearly with increase in head temperature. At the same time, the amount of air required to carry off a given amount of heat falls off approximately linearly with increase in head temperature. As a result, the amount of cooling air required varies inversely as the square of the head temperature. Since the baffle pressure drop varies as the square of the air flow, the net effect is that the baffle pressure drop varies inversely as the fourth power of the head temperature. Campbell,⁴ after analysis of many data on a number of different engine models, arrived at the empirical exponent of 3.7 instead of 4.0. This agrees closely with the rough approximation made above, especially considering the number of minor factors neglected in arriving at the exponent 4.0. Figure 89 shows results from actual tests. Note that a wide range of speeds was covered, the brake horsepower being kept constant. When plotted on log-log coordinates, these same

data fell on a straight line, giving an exponent of 3.5 with a scatter of only 4 per cent.

This relationship is extremely important because it shows the great advantage to be gained in the way of decreased baffle pressure drop required if the allowable cylinder-head temperature can be increased. In general, the airplane manufacturer has

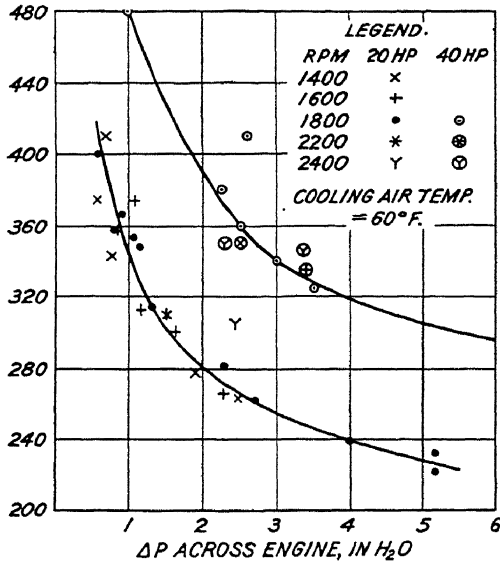

FIG. 89.—Cooling-air pressure drop across a Franklin 4AC176 65-hp engine plotted against cylinder-head temperature with horsepower and cooling air temperature held constant. (Daniel Guggenheim School of Aeronautics, New York University.)

difficulty providing an adequate baffle pressure drop for engine cooling so that the engine manufacturer has been under constant pressure to increase the maximum allowable head temperature, thus reducing the amount of cooling required.

Effect of Power Output.—For a constant head temperature and fuel-air ratio, the heat rejection increases approximately as the 0.7 power of the indicated horsepower (see Fig. 84). Thus the baffle pressure drop increases approximately as the 1.4 power of the indicated horsepower. Figure 90 is a cross plot of data from several curves like those of Fig. 89, run at different horsepowers, and shows this relationship.

Effect of Fuel-Air Ratio.—As was pointed out earlier, heat rejection to the coolant falls off rapidly as the mixture is enriched

from the best power region. Cooling of air-cooled engines under take-off and low-speed climbing conditions is made much less acute by the simple expedient of "cooling the engine with gasoline," *i.e.*, enriching the mixture.

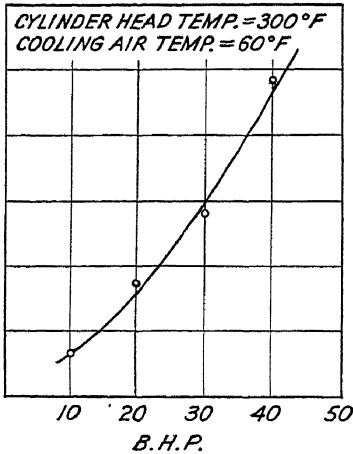

FIG. 90.—Cooling-air pressure drop required to maintain a constant head temperature plotted against engine power output for a Franklin 4AC176 65-hp engine. (*Daniel Guggenheim School of Aeronautics, New York University.*)

As pointed out before, a reduction in heat rejection of 25 per cent can be obtained by using rich mixtures, giving a similar reduction in the cooling air flow needed to maintain a given head temperature. The baffle pressure drop required varies as the square of the air flow, and therefore it can be reduced nearly 50 per cent, thus making adequate cooling possible in many cases in which the available baffle pressure drop is limited, as under take-off conditions.

Predetermination of Head Temperature.—Campbell⁴ has

$$= T_a \quad (27)$$

where T_h = cylinder-head temperature, °F.

T_a = cooling air temperature, °F.

K = a constant for any particular engine model.

ihp = indicated horsepower.

$isfc$ = indicated specific fuel consumption, lb per bhp hr.

$\sigma\Delta p$ = baffle pressure drop, in H_2O .

Although this equation applies only if the fuel consumption is richer than that for best power, virtually all the critical operating points fall in or near this range. The equation is useful because it makes possible the prediction of engine-cooling requirements for any conditions on the basis of a relatively small amount of test data taken when conditions had been well stabilized.

Careful consideration of the various elements of the preceding equation on the basis of the individual relations developed in this chapter will show that it is reasonable. The exponent for the baffle pressure drop, for example, was deduced above (see Fig. 89 and the accompanying discussion). The exponent of the indicated-horsepower term can be deduced from Fig. 84 and the

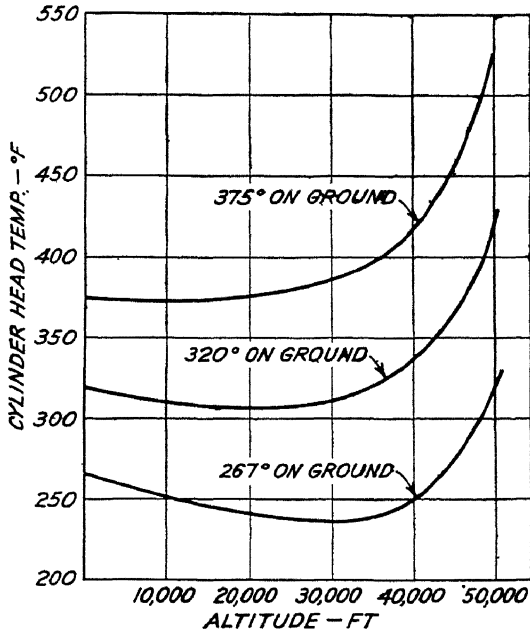

Fig. 91.—Effect of altitude on the cylinder-head temperature of an engine operating at constant power in level flight with a fixed cowl-exit slot. (Fedden, *S.A.E. Trans.*, vol. 32, 1937.)

discussion that accompanies it. Since the specific fuel consumption varies over such a small range, its effect is closely approximated by an empirical exponent based on experimental data. It is interesting to note that the exponents shown above have been found to hold within the limits of experimental error for a variety of engine types ranging from light plane engines to the largest aircraft engines in service.

Effects of Altitude.—Although the effect of altitude on air density is included in the preceding analysis, the effect of altitude on the cooling air temperature is not. Further, the level-flight air speed of an airplane operated at a constant engine power output increases with altitude. The combined effect of all the

factors involved is shown in Fig. 91. It shows that an installation giving low head temperatures in level flight at sea level will give still lower head temperatures at altitudes up to about 30,000 ft, while an installation giving high level-flight head temperatures at sea level will give increasingly higher temperatures at altitude. This is caused by the relatively great effect of the change in cooling air temperature with altitude in cases in which the sea-level temperature difference is on the order of 150°F. as contrasted with the comparatively small effect when the temperature difference is on the order of 350°F.

Effect of Detonation.—Detonation in high-output air-cooled engines results in some increase in heat rejection. The rear spark-plug gasket temperature is normally taken as the reference temperature for the cylinder head. It seems to be especially sensitive to detonation. This suggests a method commonly used to rate fuels in full-scale engine tests. Constant-throttle mixture-control curves are run; and head temperature, in addition to horsepower and specific fuel consumption, is plotted against fuel flow. Detonation is indicated by an abrupt increase in head temperature and some loss in power.

LIQUID-COOLED ENGINES

Effect of Coolant Temperature.—The temperature of the coolant leaving the cylinder head is ordinarily the reference temperature for the engine. Since the coolant boiling point is usually the limiting consideration, an allowable maximum value is readily established for a particular engine and coolant. As was pointed out before, increase in the cylinder-head temperature results in a marked decrease in engine heat rejection. This is very important for the liquid-cooled engine, for it means a decrease in radiator size and weight and, especially, in drag. Use of ethylene glycol (prestone) instead of water permits coolant outlet temperatures of about 260°F instead of 180°F, giving a net reduction in the required radiator size of about 70 per cent. This great reduction is made possible both by the decrease in total heat rejection from the engine to the coolant and by the increase in temperature difference between the radiator and the cooling air so that less of the latter is required.

Over-all Characteristics.—Figure 92 shows coolant flow, heat rejection to the coolant, and engine power output plotted

against rpm at full throttle for a German Daimler-Benz DB601 engine. Note how nearly the coolant-flow and heat-rejection curves approach straight lines.

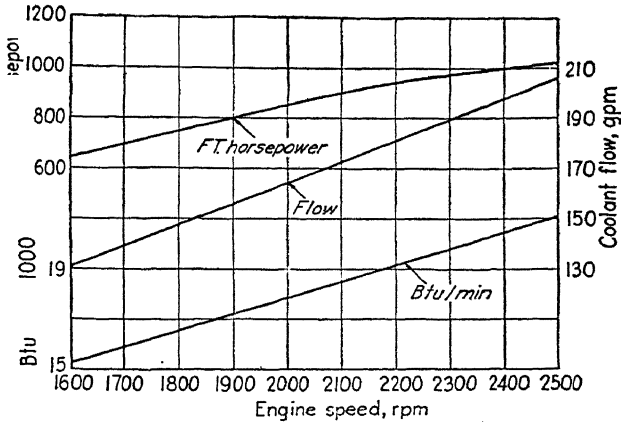

FIG. 92.—Heat rejection to the coolant of a DB601A engine at sea level—coolant, 50 per cent by volume of ethylene glycol in water; temperature out, $188^{\circ}\text{F} \pm 5^{\circ}\text{F}$. (*Young, S.A.E. Trans.*, vol. 49, 1941.)

References

1. PINKEL, B.: Heat Transfer Processes in Air-cooled Engine Cylinders, *N.A.C.A. Tech. Rept.* 612, 1938.
2. BIERMAN, A. E.: The Design of Metal Fins for Air-cooled Engines, *S.A.E. Trans.*, vol. 32, 1937.
3. McADAMS, W. H.: "Heat Transmission," 2d ed., McGraw-Hill Book Company, Inc., New York, 1942.
4. CAMPBELL, K.: Predetermination of Aircraft Engine Cooling Requirements for Specific Flight Conditions, *Jour. I.A.S.*, vol. 7, No. 4, February, 1940.

CHAPTER X

VIBRATION

Vibration has demanded a considerable amount of attention in recent years because of troubles that have arisen in many airplanes. In most cases the engine and/or the propeller have quite properly been held responsible. A number of effective steps have been taken so that most vibration troubles can now be prevented by proper design. Actual design work is involved, but an understanding of the basic principles of vibration, a conception of the nature of the forces causing vibration, and some idea of the types of motion that occur can be presented here.

VIBRATING SYSTEMS

Examples and Definitions.—There are many types of vibration phenomena to which the same general mathematical relations apply, but we are concerned here only with the vibration of elastic bodies and elastically coupled mechanical systems.

The tuning fork is a good example of a vibrating body. A tine, once set in motion, tends to vibrate. It moves from one extreme position to another, each particle having *simple harmonic motion* as in the stretched string. The *natural period of vibration* of the fork is constant for any given case and is a function of the section modulus, the length, and the material of the tines. The *frequency* of the vibration in cycles per second is the reciprocal of the *period*, *i.e.*, the time in seconds required for one cycle. The frequency at which the fork tends to vibrate is called its *natural frequency*. If the fork is struck with a mallet, energy is put into it, and the fork will vibrate at its natural frequency until the energy is dissipated by the friction losses accompanying the vibratory motion. The amplitude of the motion, *i.e.*, the maximum displacement during a half cycle, will fall off rapidly at first and then more slowly until the motion gradually dies out. Such dissipation of energy is called *damping*.

The vibrating diaphragm, such as a drumhead, affords another common example of the vibration of elastic bodies, as does the

coil spring, which may surge longitudinally. Both these types of vibration are found in aircraft engines. Perhaps the most important form of vibration within the engine, however, is *torsional vibration*, in which a mass oscillates torsionally, twisting an elastic shaft. The balance wheel of a watch is an example of a system vibrating torsionally, with a period of $\frac{2}{5}$ sec.

Free Vibrations.—Simple vibrating systems are readily analyzed mathematically. The results of such an analysis are especially valuable because they bring out the form of the principal relationships. Take as an example the cantilever beam with the mass w at the free end shown in Fig. 93. Its spring constant k would be the force required to deflect the free end vertically 1 in. If the beam were set to vibrating, the principal forces acting would be the inertia force of the mass and the spring force of the beam. Neglecting the mass of the beam and calling the displacement from the mean position x , the equation of motion would then be

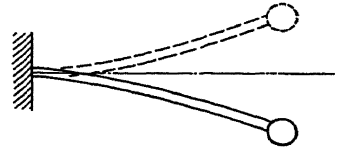

FIG. 93.—Vibrating weight at the end of a cantilever beam.

$$w \, d^2x \quad (28)$$

where w = displacement force, lb.

k = spring constant, lb per in.

ω = frequency, radians per sec.

g = acceleration force of gravity, in per sec per sec.

A solution of this differential equation has been found to be

$$X = A \cos \omega t - B \sin \omega t$$

where A and B are undetermined coefficients and $\omega = \sqrt{\frac{kg}{w}}$

The period of the vibration is the time required for one cycle when the weight w is released.

For cases in which the motion takes place in the vertical direction, w/k = static deflection, δ_{static} , from the equilibrium position, and

$$\omega = \sqrt{\frac{kg}{w}} = \sqrt{\frac{g}{\delta_{\text{static}}}}$$

Inspection shows the time T required for one cycle would be

$$f = \frac{\omega}{2\pi} \text{ cycles per sec}$$

$$T = \frac{1}{f} = \frac{2\pi}{\omega} = 2\pi \sqrt{\frac{\delta_{\text{static}}}{g}} \quad (29)$$

The natural frequency f_n becomes

$$f_n = \frac{1}{T} = \frac{1}{2\pi} \sqrt{\frac{g}{\delta_{\text{static}}}} = \frac{1}{2\pi} \sqrt{\frac{gk}{w}} \quad (30)$$

This gives the important relationship between the natural

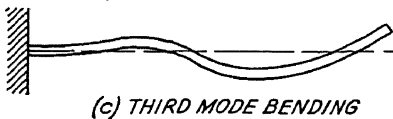
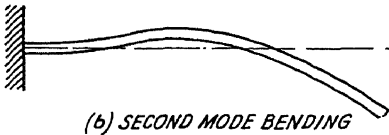
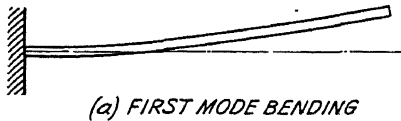

FIG. 94.—Modes of vibration of a cantilever beam.

frequency of a simple system and its spring constant k . This shows that decreasing the weight causing the displacement or increasing the stiffness of a system increases its natural frequency.

The expression for f_n in terms of the static deflection is an especially useful form for application to a system such as that of an engine mounted in rubber bushings where the engine would tend to move vertically. In a case of this sort the

deflection of the rubber bushings, or "springs," under the static load of the engine can be readily measured or calculated. The natural frequency in the vertical direction of the engine on its mount can then be calculated from Eq. (30).

If an actual cantilever beam is tested, with the mass of the beam large relative to the mass at the end, it will be found to be capable of vibrating in a number of different forms. It may vibrate as in Fig. 94a; it may have one point of inflection as in Fig. 94b; it may have two points of inflection as in Fig. 94c; or it may have an even greater number of points of inflection. These forms of beam deflection are referred to as *modes*. The case shown in Fig. 94a is the *first mode*, that in Fig. 94b the *second mode*, etc. The frequency of the second mode is greater than that of the first and is referred to as the *first*

harmonic. Similarly, the frequency of the third mode is still greater than that of the first and is called the *second harmonic*.

Points in a vibrating body that do not move are called *nodes*. In the beam example, the nodes would be at the points of inflection. Wings, propeller blades, and other aircraft parts behave in much the same manner as this simple cantilever beam and may vibrate in a wide variety of modes over a correspondingly wide range of natural frequencies.

Crankshaft Vibration.—One seldom finds an actual example of vibration in which only one body is concerned—an elastically

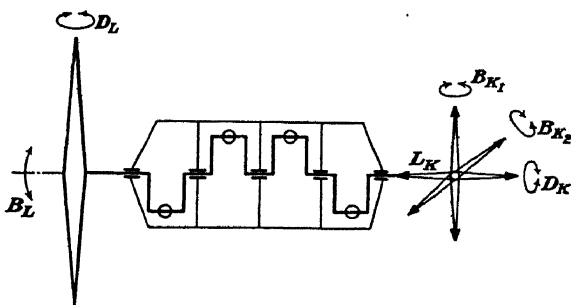

FIG. 95.—Degrees of freedom in the crankshaft-propeller system of a direct-drive in-line engine. (Lürenbaum, *S.A.E. Trans.*, vol. 31, 1936.)

coupled system of bodies is far more common. The system, or some parts of it, may vibrate in a variety of modes at any one of a number of natural frequencies. A common example of such a system is the crankshaft of an in-line engine, each crank throw of which may be considered as a mass and the connecting journals as the elastic couplings. The system may vibrate torsionally; it may vibrate in bending as a beam restrained at each main bearing; or it may vibrate longitudinally as a spring in an accordionlike motion. The propeller at the front end of the shaft constitutes the largest mass in the system, and so usually enforces a node near its center of gravity.

An important factor to be considered in an analysis of a vibrating system is its *freedom* to vibrate, the different directions in which motion may occur being spoken of as the *degrees of freedom*. Take, for example, the four-cylinder in-line crankshaft and direct-drive propeller shown in Fig. 95. At the front

end the shaft may bend in a vertical plane, or it may bend in both vertical and horizontal planes simultaneously to give conical whirling. It is free to vibrate torsionally, restrained only by the mass of the propeller. It may be free to vibrate longitudinally if the clearances in the thrust bearing are sufficiently large. At the rear end the same conditions exist except that there is no mass

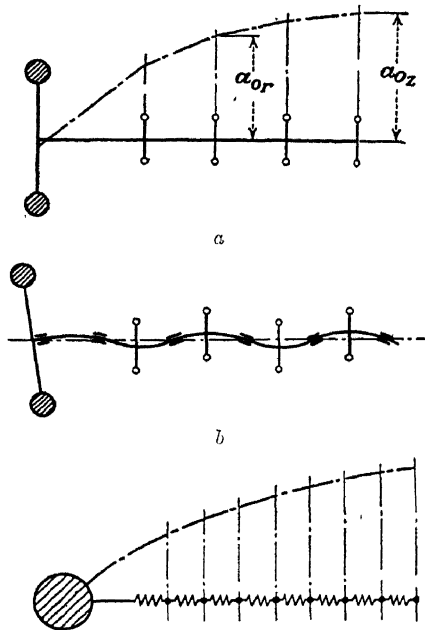

FIG. 96.—Types of vibratory motion commonly found in the crankshaft-propeller system of Fig. 95. (Lürenbaum, *S.A.E. Trans.*, vol. 31, 1936.)

like that of the propeller to be considered. Thus both ends of the crankshaft may have four degrees of freedom. Internally, the system is restrained radially at the main bearings. The crank throws and the reciprocating weights can be considered for the moment as masses concentrated between the main bearings.

Figure 96a indicates the form of the torsional vibration, the ordinate of the dotted line being the amplitude at each point along the crankshaft. It shows that the angle of twist would be small and in one direction at the propeller, falling off to zero at a point just behind the propeller. From that point the direction of the angle of twist would be opposite to that of the propeller

itself, and the amplitude of the twist would increase rapidly at first and then more slowly toward the rear of the shaft. Figure 96*b* shows vibration of flexure in which the crankshaft is a vibrating continuous beam restrained at the bearings. For the case of longitudinal vibration, Fig. 96*c* shows an equivalent system of masses connected by springs, the ordinate of the dotted line again being the relative amplitude of points along the shaft. In this case, the propeller would have a small fore-and-aft motion opposite in phase to that of the crank throws, with the greatest amplitudes again at the rear.

This example indicates the possibility of one of the principal ill effects of vibration—high stresses. Any twisting or bending must be accompanied by stresses that are proportional to the amplitude of the motion. At points of stress concentration such as in splines or at the relatively sharp corner between the crankpin and crankcheek, these stresses may exceed the fatigue strength of the material, causing failure of the part.

Forced Vibrations.—The vibrating string and the tuning fork are examples of “free” vibrations, in which energy put into a system causes it to vibrate at its natural frequency until that energy is dissipated by damping. Most cases of importance in aircraft, however, involve “forced” vibrations, in which a periodic excitation forces a system to vibrate at the frequency of the excitation. In such cases, the amplitude of the resulting motion depends upon the ratio of the exciting force frequency to the natural frequency of the system, upon the magnitude of the exciting force, and upon the damping available to dissipate the energy of the exciting forces. Take, for example, a cantilever spring with a mass at the end. A static force applied at the end will cause a certain deflection. If an alternating force is applied with a very low frequency of, say, one cycle per minute, the amplitude of the resulting motion will be approximately equal to the static deflection under the same load. If the frequency of the exciting force is increased, it will be found that the amplitude will increase slowly at first and then more and more rapidly as the exciting frequency approaches that of the natural frequency of the system. In this region the amplitude is limited principally by the damping, which absorbs the energy put into the system. If the frequency of the exciting force is increased above that of the natural frequency, it will be found that the amplitude of

the motion will fall off rapidly. Figure 97 shows a curve of amplitude vs. frequency for a system of this type. This curve is extremely important. Its validity should be established in the student's mind both by rational consideration of this type of motion and by actual tests of a simple character.

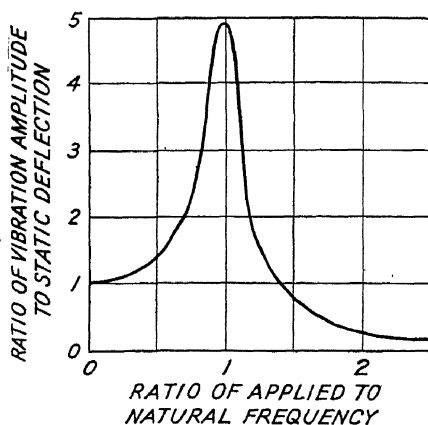

Fig. 97.—Amplitude as a function of forcing frequency for a simple system subject to an exciting force of constant magnitude.

VIBRATION-EXCITING FORCES

Vibration in Aircraft.—Aircraft vibration troubles might be grouped in three classifications, *viz.*, propeller-blade vibration, vibration of engine parts such as the crankshaft or accessory drive shafts, and vibration of the airplane structure. An exciting force acting at some point on the airplane structure will, in general, be transmitted to other points, probably causing large amplitudes of motion of some parts having natural frequencies approximately equal to that of the exciting force.

The principal exciting forces in an airplane come from the engine-propeller combination. These exciting forces may cause serious vibration in either the engine or the propeller, or they may be transmitted to the airplane structure and cause vibration of such parts as wing tips, control surfaces, floor boards, or instrument panels. These vibration-exciting forces may be set up by engine or propeller unbalance, the firing impulses of the cylinders, aerodynamic forces on the propeller blades, or gyroscopic forces set up by the propeller.

Static Balance.—The term *balance* implies a teeter-totter arrangement in which a body or system of bodies is free to rotate about an axis. If the moment tending to cause rotation in one direction is balanced by an equal and opposite moment acting in the opposite direction, the system is said to be *statically balanced*. That is, the product of the weight on one side of the axis and the distance of its center of gravity from that axis must be equal to the weight on the other side times its moment arm. Figure 98 shows a two-throw crankshaft in which the mass of each crank throw is represented by an equivalent mass on each crankpin. The system can be statically balanced by adding or subtracting weight from either equivalent mass.

Dynamic Balance.—As soon as the shaft of Fig. 98 begins to rotate, a new set of forces appears. In addition to the static force of gravity acting on each crank throw, centrifugal force begins to act and may reach a value 1,000 times as great as that of the gravitational force. The centrifugal force is given by the familiar expression

$$F = \frac{W}{g} r\omega^2$$

where W = weight, lb.

r = distance of its center of gravity from the axis of rotation, ft.

ω = angular velocity, radians per sec.

This centrifugal force acts radially outward from the axis of rotation, passing through the center of gravity of the mass on that side. It is evident that the above shaft would be acted on

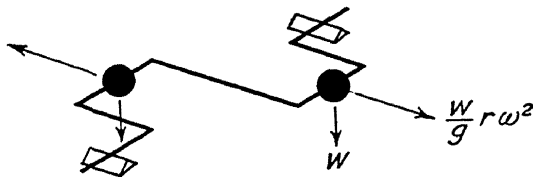

FIG. 98.—Forces acting on a two-throw crankshaft in static balance.

by a couple if rotated, for the lines of action of the two centrifugal forces would be in opposite directions and would intersect the axis at two different points (see Fig. 98). To place this shaft in dynamic balance it would be necessary to add another couple equal and opposite to that acting on the original shaft. This may

be done by placing *counterweights* on the crankcheeks as shown in Fig. 99. This would keep the system in static balance because

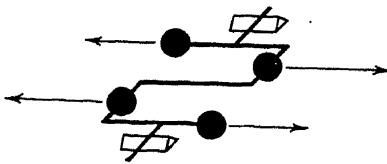

Fig. 99.—Forces acting on a two-throw crankshaft in dynamic balance.

the product of mass and the moment arm of the center of gravity affects both static and dynamic balance according to the first power. To put it mathematically, for dynamic balance, the summation of inertia moments about a point on the axis of rotation

must be equal to zero. This relation must hold for any plane passed through the axis of rotation.

Unbalance Due to Reciprocating Parts.—All existing aircraft engines are of the type in which power is transmitted from pistons through connecting rods to the crankshaft. The inertia

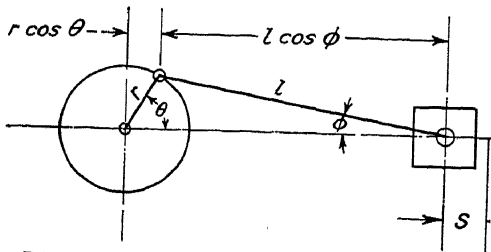

Fig. 100.—Diagram showing the geometry of rod and piston positions.

forces set up by these moving parts must be balanced. However, since the motions of the parts concerned are complex, the problem of balancing them is an involved one. Figure 100 shows a crank of radius r that is linked to a piston by a rod of length l , and the displacement of the piston from upper dead center is given by s . The value of this displacement is given by

$$s = l + r - (r \cos \theta + l \cos \phi) \tag{31}$$

But

$$\cos \phi = (1 - \sin^2 \phi)^{1/2}$$

and

$$\sin \phi = \frac{r}{l} \sin \theta$$

It has been found convenient for purposes of analysis to substitute the latter in the equation for displacement and expand to obtain a Fourier series in which the constants are functions of

r and r/l , while the variable is θ , the crank angle. The equation becomes

$$s = A_0 - A_1 \cos \theta - A_2 \cos 2\theta + A_4 \cos 4\theta - A_6 \cos 6\theta + \dots \quad (32)$$

The coefficients are all functions of r and l . Their absolute value decreases rapidly as the order of the term is increased.

This series is easily differentiated once to obtain velocity and twice to obtain acceleration, the general form remaining the same. Thus it is evident that the resulting accelerating forces will set up a dynamic unbalance which will be at first, second, fourth, sixth, and higher orders of crankshaft speed. The first order rotating component can be balanced out by counterweights fastened directly to the crankshafts. In some cases, the second order component in a twin-row radial engine has been reduced in practice by driving unbalanced weights in the direction of crankshaft rotation at twice engine speed and 180 deg out of phase to the secondary rotating couple.

Balance of In-line Engines.—In in-line engines the crank throws are so placed that the shaking forces of each piston are balanced by those of the other pistons. The six-cylinder engine has been popular because virtually all these shaking forces balance out. The crank throws of cylinders Nos. 1, 2, and 3 are placed at 120 deg with respect to each other. The shaking forces they set up are almost completely balanced out. A *rocking moment* is set up which tends to rock the crankshaft in a vertical plane because, though the forces balance each other, their lines of action intersect the crankshaft at different points and so give a couple. This is taken care of in the six-cylinder engine by making the crankshaft symmetrical about its mid-point, thus balancing the couples of the two halves against each other. The four-cylinder engine is made in a similar fashion, but a detailed analysis will show that in it the nearly perfect dynamic balance of the six-cylinder engine cannot be obtained. Although not mentioned above, *rolling couples* are set up by the forces required to oscillate the connecting rods. These are completely balanced out in the six-cylinder engine. The V-engine, being two in-line engines side by side, has essentially similar vibration characteristics.

Balance of Radial Engines.—In the single-row radial engine, the problem is somewhat different. The shaking forces due to each reciprocating piston and oscillating rod all act on one crank-pin, their lines of action passing through the same point. Analysis shows that, if a true-motion rod system is used (*i.e.*, one in which the pistons and rods each have the motion shown in Fig. 100), the shaking forces are partly balanced out in the three- and five-cylinder engines and completely balanced out if seven or nine cylinders are used.

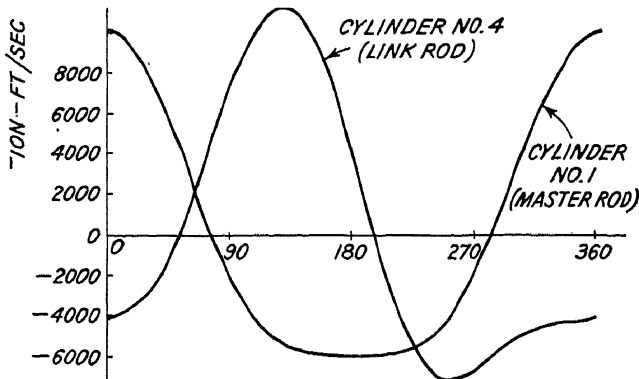

FIG. 101.—Acceleration curves for the master-rod piston and an articulated-rod piston in a nine-cylinder radial engine having a 5-in. stroke and operating at 1,880 rpm.

However, no true-motion rod system has been devised that has proved practicable for aircraft engines. The articulated-rod system in current use complicates things very seriously. Figure 100 must be modified to break the connecting rod of length l up into two links, one of which is the master rod and the other the link rod. Since the relative motion of the master rod and link rod is different for each cylinder, no two pistons move exactly alike. Typical acceleration curves for the master-rod piston (for No. 1 cylinder) and an articulated-rod piston (for No. 4 cylinder) of a seven-cylinder radial engine are shown in Fig. 101. Note that the acceleration and thus the inertia forces at top dead center are 17 per cent greater for the latter than for the former and that the general form of the acceleration curve is decidedly different. The result is that shaking forces of practically all orders are set up. By far the most important of these is the second order force, which is responsible for much of the

vibration trouble encountered with aircraft engines. In twin-row radials, it becomes especially troublesome, for an unbalanced couple results. This couple revolves both at twice crankshaft speed and at higher orders. The various orders tend to alternate, reinforcing and extinguishing each other, and beats are thus caused in which the amplitude of vibration may become quite large.

Deflection Unbalance.—In any actual engine, another difficulty arises as a result of the deflections occurring under operating loads. This is particularly troublesome in the case of the long crankshafts of in-line engines. These deflections throw the shaft out of alignment and cause dynamic unbalance. To reduce the forces causing these deflections, counterweights may be placed on each crankcheek of the in-line crankshaft. It is interesting to note that the old Liberty engine crankshaft had no counterweights, while the modern Allison V-1710 has a counterweight on each crankcheek.

Combustion Forces.—The forces of combustion are imposed on the crankshaft in an intermittent fashion. The crank throws and the firing order of the cylinders are so arranged that the firing impulses act on the crankshaft at uniform intervals of crankshaft rotation. This is the reason why the radial engine is built with an uneven number of cylinders—since each cylinder fires only every other revolution, a uniform frequency of torque input cannot otherwise be obtained with a four-cycle engine. Similarly, it is one of the determining considerations in the layout of in-line engines and is the reason why 8-cylinder V-engines ordinarily have 90 deg between banks while 12-cylinder V-engines make use of a 60-deg angle.

Each power impulse from a cylinder causes a torsional acceleration of the crankshaft. The reaction forces from these power impulses are one of the most serious sources of airplane vibration. The gas forces that act upward against the cylinder head and downward against the piston are balanced out within the engine. The upward force is transmitted from the cylinder head down through the barrel into the crankcase, where it is opposed by the vertical reaction in the main bearings. The horizontal force on the cylinder wall due to the angularity of the connecting rod, however, is accompanied by an equal and opposite but not collinear horizontal force at the main bearing. These two forces

constitute a couple equal and opposite to the torque input to the crankshaft. This couple, like the torque input to the crankshaft, is periodic. The resulting torsional oscillation of the crankcase may cause serious vibration in the airplane structure.

Crankshaft Torque Variation.—Serious torsional vibration in the crankshaft-propeller system may be caused by the periodic torque input to the crankshaft. This is due to the fact that the mass of the crank, counterweights, and reciprocating parts is elastically coupled to the propeller to form a system responsive

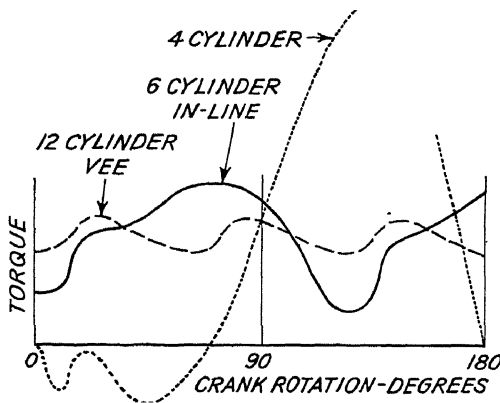

FIG. 102.—Curves showing the net torque acting on the shafts of conventional 4- and 6-cylinder in-line and 12-cylinder V-engines. (*Crane, S.A.E. Trans., vol. 28, 1933.*)

to a fairly wide range of frequencies. The greater the power input per cylinder, the greater will be the torsional-vibration problem. Torsional vibration in the single-row radial engine became very serious as development brought out engines giving 100 and more horsepower per cylinder.

The amount of the torque variation falls off rapidly with an increase in the number of cylinders connected to the same crankshaft (see Fig. 102). Note that the torque is actually negative for about 40 per cent of the cycle in the 4-cylinder engine. The 6-cylinder engine shows a large torque variation, while the 12-cylinder 60-deg V-engine gives a relatively smooth torque input to the crankshaft. Were it not for crankshaft flexibility between crank throws, torque variation would not present much of a problem in engines having 12 or more cylinders.

The relative magnitudes of the various harmonic components of the above torque curves are important in the analysis of vibration-test results. Table II gives these components for nine-cylinder radial and eight-cylinder in-line engines of conven-

TABLE II.—HARMONIC-TORQUE COMPONENTS IN PERCENTAGE OF MEAN TORQUE²

Order No.	9-cylinder radial	8-cylinder conventional
$\frac{1}{2}$	1	0
1	5	0
$1\frac{1}{2}$	1	0
2	6	0
$2\frac{1}{2}$	2	0
3	2	0
$3\frac{1}{2}$	3	0
4	1	51
$4\frac{1}{2}$	42	0
5	2	0
$5\frac{1}{2}$	6	0
6	2	0
$6\frac{1}{2}$..	0
7	1	0
$7\frac{1}{2}$..	0
8	..	13
$8\frac{1}{2}$..	0
9	8	0
$9\frac{1}{2}$..	0
10	..	0
$10\frac{1}{2}$..	0
11	..	0
$11\frac{1}{2}$..	0
12	..	6

tional types. It includes both gas- and inertia-torque variations. The column headed Order No. gives the number of cycles of the harmonic per revolution of the crankshaft. Thus, for the nine-cylinder radial the $4\frac{1}{2}$ order harmonic would cause a torque variation of 42 per cent. The relatively large and complex inertia-torque variation caused by the articulated-rod system

is responsible for the large number of harmonics for the radial engine. Ordinarily, the bulk of these harmonics have negligible effects; but should any element in the crankshaft-propeller system have a natural frequency equal to the frequency of a harmonic, serious amplitudes might result. Note that the only large torque harmonics for either type engine are firing frequency and twice firing frequency.

The impulses due to the periodic combustion forces, and the translational piston and rod inertia forces in a plane perpendicular to the crankshaft are the most important vibration-exciting forces generated within the engine. The following important modes of vibration result: torsional vibration of the crankshaft; propeller-shaft whirl brought about by gas-expansion forces acting through the connecting rods upon the crankshaft so that, owing to some diametral clearance in the bearing that supports the front crankshaft journal coupled to the propeller shaft, the gas forces displace the journal radially, causing a conical whirl of the propeller shaft with a node near the front thrust bearing; and whirls that are due to rotating vectors of connecting-rod first and second order unbalance in single- and multiple-row radial engines.

VIBRATION DAMPERS

Friction Dampers.—Several types of friction damper have been used to dampen out torsional vibration in internal-combustion engines. Perhaps the most important of these has been the Lanchester damper, in which disks having considerable inertia are mounted on the shaft. These are held by springs against other disks rigidly connected to the shaft. The first set of disks is restrained from rotation with respect to the shaft only by frictional forces between the faces of the two sets of disks. This type of damper tends to take the peak off the amplitude curve but causes a corresponding loss in energy and makes necessary the removal of a considerable amount of heat if vibration is severe enough to require the device. The vibration damper used on the propeller shafts of Allison V-1710-C15 engines is a modification of this type of damper.

The Dynamic Damper.—The compound pendulum offers another method of reducing torsional vibration. A swinging pendulum sets up a horizontal reaction at its point of support.

As the pendulum swings from side to side, this horizontal reaction alternates in direction, giving a periodic force. If a pendulum is suspended from a crankcheek as shown in Fig. 103 and the crankshaft given a twist in one direction, the pendulum will swing in the opposite direction relative to the crankshaft, setting up a restoring force. If a periodic torque is applied to the crankshaft at the natural frequency of the pendulum, it will be found that, if the pendulum has sufficient mass, it will swing back and forth with an amplitude such that it will set up a force equal and opposite to the force tending to rotate the crankshaft. The result will be that the torsional motion of the shaft will be greatly reduced.

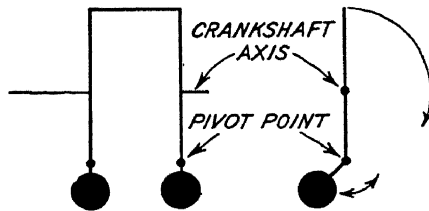

FIG. 103.—Schematic diagram of a pendulum-type vibration absorber.

If the shaft is rotated at high speed, the restoring force on the pendulum will be proportional to the centrifugal force acting on it rather than its weight. Since the frequency of any vibration is proportional to the square root of the restoring force and since in this case that is proportional to the square of the rpm, the natural frequency of the pendulum is directly proportional to the speed. This makes it possible to eliminate most of the torsional vibration at firing frequency in radial engines through the use of such a pendulum. The pendulum can be "tuned" to firing frequency by properly adjusting the radius of the arc through which the pendulum swings and the distance of the center of that arc from the center of the crankshaft. It happens that, in actual engines, this requires that the effective pendulum length be very short, and yet a comparatively large pendulum mass must be provided. One method of doing this is to place a disk in a slightly larger hole counterbored in the crankcheek as shown in Fig. 13. The disk can roll up on either side of the hole, in effect constituting a pendulum having a length equal to the difference between the radii of the disk and the hole. A somewhat similar and even more effective arrangement because of the larger mass that can

be put into the pendulum is shown in Fig. 14. This is the bifilar type devised by Chilton. The counterweight, is used as a pendulum, being supported by pins passed through holes of somewhat larger diameter in both the crankcheek and the counterweight. The effective length of the pendulum in this case is the difference in diameter between the damper pins and the holes in which they ride. Figure 12 shows a picture of a shaft fitted with dynamic dampers of this type.

Although the damper removes only the frequency for which it is tuned, firing frequency gives by far the most important harmonic. By removing it, an engine giving serious crankshaft torsional vibration may be made entirely satisfactory from that standpoint.

VIBRATION-EXCITING FORCES IN THE PROPELLER

Propeller Mass Balance.—Just as in a rotating shaft, a small static unbalance will set up a large force which rotates at propeller speed. Also, as in a rotating crankshaft, a statically balanced propeller may set up an unbalanced rotating couple when run. This may be due to misalignment of the blades in the hub. If, for example, one blade is inclined forward, its mass will not rotate in the same plane as that of the other blades and a vibration-exciting couple will be set up.

Gyroscopic Forces.—In violent maneuvers, two-bladed propellers will set up large periodic forces at twice engine speed owing to the fact that the mass of the propeller about the hub is many times greater in the direction of the blades than at right angles to them. Thus the "gyroscopic resistance" to a change in direction of the axis of rotation is small when the blades lie in the plane of the maneuver but is quite large when perpendicular to it. The resulting exciting force caused little trouble in wood propellers but became very serious with the advent of metal propellers. Fortunately, propellers having three or more blades give no trouble because the gyroscopic force is the same for any position of the blades and no periodic force is set up.

Aerodynamic Balance.—Differences in blade angle may occur between blades, particularly in variable-pitch propellers. These differences will cause the thrust force acting on the individual blades to be different, thus setting up a rotating couple. This couple may often be balanced fairly well in an actual propeller

by making use of an equal and opposite inertia couple, for both aerodynamic and inertia forces vary as the square of the rpm.

Aerodynamic Interference Forces.—The most easily visualized aerodynamic interference forces on a propeller are those commonly found in twin-engine airplanes. Each time a propeller blade passes the leading edge of the wing, a pressure is built up between the two, and the extra thrust momentarily forces the propeller blade forward. This occurs each time a blade passes the wing, or six times per revolution for a three-bladed propeller. The landing gear, or any other projection, may have the same effect.

Another source of difficulty is the air stream close to the fuselage. It has a higher velocity than the main air stream; hence, the relative angle of attack of the propeller blade is less and the thrust force on it is decreased. Similar effects occur where one propeller operates in the slip stream of another. The uneven flow of air through the propeller during climbing and maneuvers—where the blades have a higher effective angle of attack on one side than the other—sets up other exciting forces.

VIBRATION TESTING

Vibration Test Equipment.—The vibration detectors, or “pickups,” commonly used consist essentially of a small coil and a permanent magnet, both of which are attached to the engine, one rigidly and the other, the seismic element, suspended by an elastic system having a low natural period. The unit is designed so that the moving element has only one degree of freedom, for example, vertical. Thus, the only factor that can cause periodic vertical motion of one element with respect to the other is vibration in the vertical direction. Such vibration induces a current in the coil. The induced voltage is proportional to the relative velocity. If amplified in a conventional vacuum-tube circuit and fed into an oscillograph, a film record can be taken. Figure 104 is a record made in this manner. It shows the frequency of the vibration and has been integrated to give the amplitude directly. Integration or differentiation of the wave form from the pickup can be most easily accomplished electrically before feeding the amplified pickup voltage into the oscillograph, thus giving a film record in terms of amplitude or acceleration, as desired.

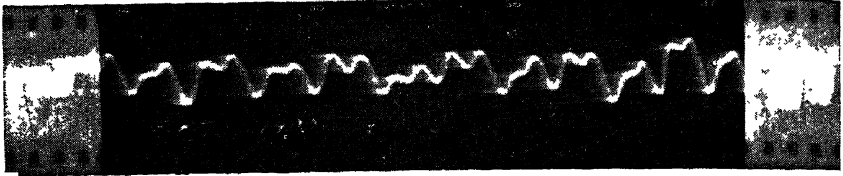
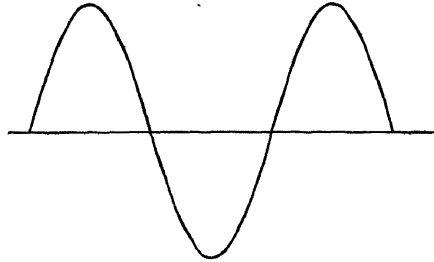
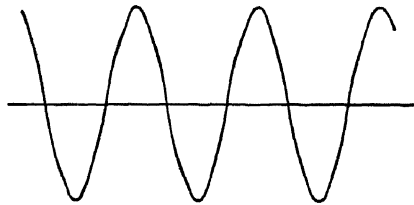

FIG. 104.—Oscillograph record showing horizontal displacement of the rear part of the crankcase of a four-cylinder opposed-type 65-hp engine. The faint vertical marks extending downward from alternate low points in the curve are timing traces made once each crankshaft revolution. (*Bonney, New York University thesis, 1942.*)



(a) SECOND ORDER COMPONENT



(b) FOURTH ORDER COMPONENT

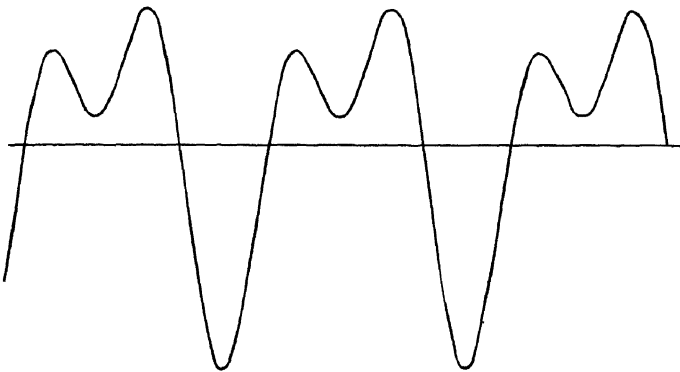

(c) COMBINED SECOND AND FOURTH ORDER COMPONENTS

FIG. 105.—Harmonic components of a motion similar to that of Fig. 104.

It is generally desirable to know the amplitude and frequency of the various harmonics of such curves. The reader should examine Fig. 104 and note that it is made up principally of second and fourth order components, as can be seen by counting the number of cycles between the timing traces on the film. The traces are one crankshaft revolution apart. Figure 105 shows how the second and fourth order components would add to give a close approximation to Fig. 104. An exact analysis can be made of oscillograph records of this sort, but the process is involved. It can be accomplished simply and directly by using a wave analyzer instead of an oscillograph. With this instrument, the amplified pickup voltage is fed into a tuned circuit, which permits electric currents of only a narrow frequency range to pass through. When in actual use, the operator changes the tuning of the instrument until it indicates a voltage, *i.e.*, a vibration, of appreciable intensity. He then adjusts the frequency to obtain the maximum voltage in that range and records both the voltage and the frequency. This is repeated until the entire frequency range has been explored at a particular engine rpm and horsepower, thus giving the amplitude and frequency of the principal harmonics.

Engine Vibration Tests.—Engine type test requirements ordinarily include vibration tests in which the amplitude of torsional vibration at both ends of the crankshaft must be measured. A torsional pickup, or "torsionmeter," is mounted as close to the rear of the crankshaft as possible. In radial engines, for example, the starter is removed and the pickup mounted directly on the tail shaft. Similarly, another pickup is attached rigidly to the center of the propeller hub. Specifications ordinarily state that the amplitude of vibration must be below $\frac{1}{2}$ deg for both points. Greater amplitudes may be caused by poor distribution of the charge in the intake manifold, faulty ignition, an improperly tuned vibration damper, etc. The frequency of the disturbance as shown on the vibration film record should indicate the exciting force responsible.

Measurement of translational vibration at specified points on the crankcase is also ordinarily required. The points commonly chosen are the governor pad on the nose section and one of the accessory drive pads at the rear. These require translational pickups similar in principle to that described.

Propeller Vibration.—In addition to the relatively constant stresses in propeller blades due to both centrifugal force and the thrust bending the blades forward, bending stresses due to vibration must be considered, for they invariably cause an increase in the maximum stress that will occur. Further, since the resulting stress changes from the maximum to the minimum many times per second, the allowable stress in the blade must be less than the fatigue limit. Vibratory stresses are the most

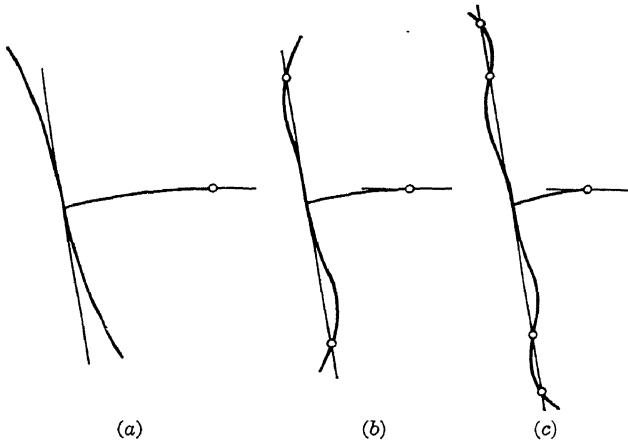

FIG. 106.—Unsymmetrical modes of propeller-blade vibration. (Lürenbaum, *S.A.E. Trans.*, vol. 31, 1936.)

difficult to design for and are the most serious of the stresses acting in the blade.

The propeller blade may vibrate in a variety of modes under the exciting forces of air loads on the blades or of engine vibration transmitted through the propeller shaft. Figure 106a shows a form of unsymmetrical vibration in a two-bladed propeller in which the blades are 180 deg out of phase with each other. The same sort of vibration may occur in a three-bladed propeller, the blades then being 120 deg out of phase with each other. Figure 106b shows the first harmonic of this type of vibration, while Fig. 106c shows the form of the second harmonic. Vibration in this form is usually set up by shaking forces or couples in the engine or by aerodynamic interference forces. Figure 107a shows a form of symmetrical vibration in which the propeller hub is in the center of a loop instead of being at a point of inflection in the vibrating propeller. It may be set up by longitudinal

vibration occurring in engines having considerable clearance in the propeller thrust bearing, by crankshaft torsional vibration, or by aerodynamic interference forces. Figures 107*b* and 107*c* show the harmonics of this "in-phase" vibration.

Unsymmetrical propeller modes of vibration are associated only with propeller whirls, whether caused by the engine or aerodynamically excited. Symmetrical propeller modes of vibration are induced by crankshaft torsional vibrations and by

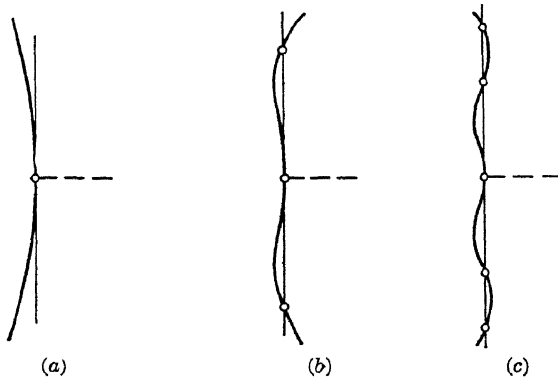

FIG. 107.—Symmetrical modes of propeller-blade vibration. (Lürenbaum, *S.A.E. Trans.*, vol. 31, 1936.)

fore-and-aft propeller-shaft oscillations, whether engine- or aerodynamically excited.

The natural frequency of propeller blades in bending is a function of engine speed because of the stiffening effect of centrifugal force. The natural period of the blades may be calculated or, better, actually measured for the static condition and the natural frequency at various propeller speeds calculated. A convenient and simple method of determining the static natural frequency of a propeller blade and the location of the nodes is to attach a vibrator to the hub and find the natural frequency of the blades. Nodes are readily located by sprinkling fine sand or sawdust on the blade and noting the points at which it tends to collect, these being the nodes—the only points practically stationary. A node for a propeller blade vibrating in bending will appear as a line chordwise across the blade, while a node for one vibrating in torsion will appear as a line extending radially outward along the blade.

Vibration-stress Measurement.—The stresses due to propeller vibration may be measured by means of carbon *pickups*, which are resistors acting as strain gauges. Any stress in the blade is proportional to the change in length at the surface. This change in length also occurs in the pickup if it is tightly cemented to the blade. Since the resistance of a carbon pile varies with its length when alternately compressed and stretched, the resistance change of the pickup is a measure of the stress existing in the propeller blade, and a calibration may be made by means of a static test. Fine wires may be run from either end of the pickup to slip rings at the propeller hub, which may be contacted by carbon brushes and thus connected to an amplifier and either an oscillograph or a wave analyzer.⁴

References

1. DEN HARTOG, J. P.: "Mechanical Vibrations," 2d ed., McGraw-Hill Book Company, Inc., New York, 1940.
2. BENTLEY, G. P., and E. S. TAYLOR: Gas Pressure Torque of Radial Engines, *I.A.S. Jour.*, Vol. 6, No. 1, November, 1938.
3. LÜRENBAUM, KARL: Vibration of the Crankshaft-propeller System, *S.A.E. Trans.*, Vol. 31, 1936.
4. KEAENS, C. M., and R. M. GUERKE: Vibration Stress Measurements in Strong Centrifugal Fields, *Jour. Applied Mech.*, December, 1937.

CHAPTER XI

FUELS AND LUBRICANTS

Petroleum has proved to be the best and most economical source of aviation fuels and lubricants. One of the most important characteristics of a fuel, for example, is its heating value in Btu per pound. The higher heating value and the specific gravity of a number of potential aviation fuels can be seen in Table III. Note that aviation gasoline has a greater heating value per pound than any of the others. In addition, it possesses other inherent advantages, not the least of which is its relatively low cost and abundance in this country. It is interesting to note that diesel fuel is somewhat heavier for a given energy content, so that the inherently superior fuel economy of the diesel as compared with the spark-ignition engine is partly offset. Note too that ethyl alcohol, often advocated as a substitute for gasoline, has a heat of combustion only a little more than half that of petroleum products. Benzol is only a little inferior to gasoline from the standpoint of heat content and is widely used as an aviation fuel in Europe. On the basis of heat content alone, it is not surprising that petroleum hydrocarbons together with benzol derivatives constitute practically all the aviation fuel actually in use today.

Several kinds of oil are available, some of which have been known and used for thousands of years. Vegetable and animal oils lubricated the axles of the first oxcarts. Even during the First World War, castor oil was widely used as a lubricant. Vegetable and animal oils, however, have the serious disadvantage that they tend to oxidize readily, especially at elevated temperatures. Gums are formed, which deposit on engine parts. These deposits are particularly troublesome on the pistons and piston rings, as they cause the latter to stick in their grooves. When this occurs, the rings lose their effectiveness as a seal and a loss in power results. Mineral oils are considerably less expensive and are far more resistant to oxidation. They have proved to be the most satisfactory aircraft-engine lubricants available.

Even though the products obtained from petroleum yield the best fuels and oils available, they are responsible for some of the most important limitations imposed on engine performance. Numerous developments in petroleum chemistry have made possible a large part of the tremendous improvement that has been made in the aircraft engine. The highly supercharged engines that develop bmep's of over 200 could operate only at low powers without 100-octane fuel—a fuel that was scarcely more than an expensive laboratory curiosity until about 1934. Similarly, these engines would require much more frequent overhaul and would be more difficult to start in cold weather if they had to operate with 1918 lubricants.

TABLE III.—PHYSICAL PROPERTIES OF FUELS¹

Fuel type	Boiling point, °F, at 760 mm	Reid vapor pressure at 100°F	Freezing point, °F	Specific gravity at 60°F	Higher heating value, Btu per lb
Straight-run gasoline.			Below -76	0.69-0.76	20,000 20,600
Cracked gasoline (pyrolytic)		7	Below -76	0.70-0.74	About 20,000
Catalytically cracked gasoline			Below -176	0.70-0.72	20,000 20,600
2,2,4-Trimethylpentane...	211	2.2	-162	0.696	20,500
Commercial mixed isooctanes.....	206-245	1.3-2.5		0.70-0.72	20,500
Isopentane.....	82	20.4	-256	0.625	20,800
Diisobutylenes (olefins)...	217	About 1.5	-150	0.715	20,300
Cyclohexane.....	178	-44	0.781	20,100
Benzene.....	175	3.2	-42	0.884	18,000
Toluene.....	231	1.3	-139	0.871	18,300
Methyl alcohol....	148	5.3	-144	0.797	9,500
Ethyl alcohol....	173	2.8	-179	0.792	12,700
Acetone.....	133	7.6	-138	0.796	13,100
Diisopropyl ether.	154	5.3	-125	0.729	16,900
Diesel fuel.....				0.860	19,500

Aviation fuels and lubricants present a set of specialized and complex problems. The nature of the fuels and lubricants themselves, together with their characteristics, the engine operating

requirements, and the various tests applied to the fuels and lubricants form the basis for this chapter.

HYDROCARBON CHEMISTRY

Carbon and hydrogen combine to form far more compounds than any other two elements. Although several thousand hydrocarbons having different numbers of hydrogen and carbon atoms have been isolated, only two oxygen compounds of hydrogen are known. Many of these hydrocarbons have nearly identical properties and are thus difficult to separate. Since virtually all present-day aviation fuel consists of hydrocarbons, and since their performance in aircraft engines differs so widely, some knowledge of their structure and characteristics is essential to an understanding of aviation fuel problems.

Types of Hydrocarbons.—Aviation fuels consist principally of four different series of hydrocarbons, *viz.*, *paraffins*, *olefins*, *naphthenes*, and *aromatics*. Each series has its own peculiarities and characteristics. Pennsylvania crude oil consists largely of paraffins, while mid-continent, west coast, and Russian crudes contain progressively smaller amounts of paraffins and larger amounts of naphthenes and aromatics to the extent that the Russian crudes consist primarily of the two latter groups. The heavier naphthenes are tarry, or asphaltic substances, and thus distillation of a California crude leaves a tarry residue; the heavier paraffins are waxy, and thus distillation of a Pennsylvania crude leaves a waxy residue. This is the reason for the terms *asphalt base* and *paraffin base* as applied to crude oils. The olefins are commonly found in the products from cracking stills in oil refineries, as will be explained later.

Aromatic compounds form only a relatively small portion of American petroleum but are the principal constituents of the products from the dry distillation of coal. Though they are not used so much for aviation fuels in this country because of the abundance of petroleum, aromatics probably constitute a large part of the aviation fuel used in continental Europe. They are also present in relatively large amounts in the fuel distilled from Asiatic crudes, notably those from the East Indies.

Molecular Structure and Nomenclature.—Paraffins have as a basis what is called a *straight-chain* structure. In these compounds, each carbon atom, except for those on the ends of the

chain, can be considered as connected to two other carbon atoms and two hydrogen atoms in the form shown in Fig. 108. The carbon atoms on the ends of the chain are each attached to one carbon atom and three hydrogen atoms. The general

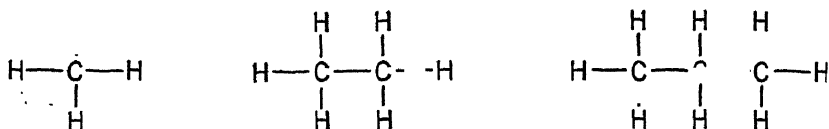

METHANE

ETHANE

PROPANE

* FIG. 108.—Conventional representation of paraffinic hydrocarbons.

formula for the series thus becomes C_nH_{2n+2} . Figure 108 shows the first few members of the series of straight-chain paraffins. Although their structure is three-dimensional as indicated in Fig. 109, the two-dimensional representation in Fig. 108 is satisfactory for most purposes of analysis.

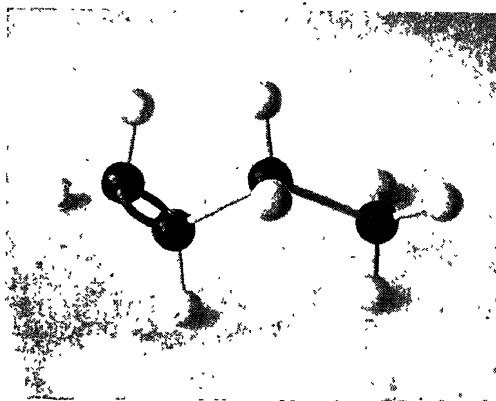
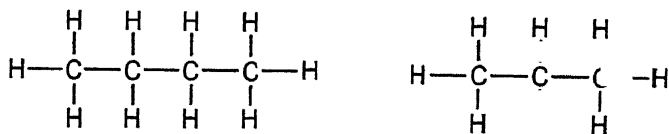

Fig. 109.—Three-dimensional model of a molecule of butylene. (*Faust, Petroleum Refiner, Vol. 21, No. 8, August, 1942.*)

A little consideration shows that there is more than one possible arrangement of the carbon atoms in a paraffin molecule having four or more carbon atoms if a carbon-to-carbon bond may replace a carbon-hydrogen bond. This is actually the case, and so there is not one substance but two having the formula C_4H_{10} . Figure 110 shows the two possible structures. Each form has slightly different properties; *e.g.*, the boiling point of one is 1°C , while that of the other is -11.5°C . That is, if the relative posi-

tions of the carbon atoms in a molecule change, a different substance called an *isomer* results. Further consideration shows that a paraffin with five carbon atoms may have three structural forms; one with six carbon atoms, any of five structures; etc.

Actual experimental work has confirmed the results of theoretical analysis: exactly the number of isomers predicted have been found for the lower paraffins. The number of isomers becomes so great for the higher paraffins that the isolation of all of them is virtually a physical impossibility. Just how much of a task it might be can be seen from a specific example. Common kerosene may contain hydrocarbons having 9 to 18 atoms of



NORMAL BUTANE

H

ISO-BUTANE

FIG. 110.—Structure of normal butane and of isobutane.

carbon in each molecule. Many of the isomers of each of these will be present. There are 35 possible substances with the formula C_9H_{20} ; 75 with that of $\text{C}_{10}\text{H}_{22}$; 159 with that of $\text{C}_{11}\text{H}_{24}$; 355 with that of $\text{C}_{12}\text{H}_{26}$; 802 with that of $\text{C}_{13}\text{H}_{28}$; 1,855 with that of $\text{C}_{14}\text{H}_{30}$; etc. (giving about 30,000 with the formula $\text{C}_{18}\text{H}_{38}$). Thus, the number of substances present having different properties is extremely large. Since the differences in their properties would be slight in most cases, separation of each from the other would be a monumental task.

Various methods have been used to describe the different paraffinic hydrocarbons. The "Geneva system" of nomenclature accurately describes any isomer of any of these hydrocarbons. The first four members of the paraffin series are given arbitrary names (see Figs. 108 and 110) while the higher members are given names involving the Greek numbers for the number of carbon atoms present, *e.g.*, pentane, hexane, heptane, octane, etc. The straight-chain variety are called *normal*, for example, normal heptane (abbreviated *n*-heptane). The various isomers may

be called by a descriptive name indicating the longest straight-chain group of which the molecule is composed. For example, the isomer of *n*-butane, shown in Fig. 110, could be called methylpropane. A similar isomer of hexane shown in Fig. 111 might

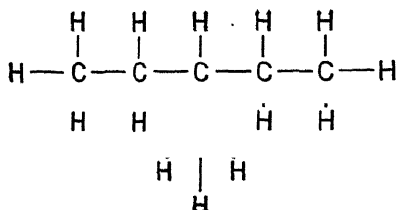

FIG. 111.—Isomer of hexane, which might also be called methyl pentane.

be called methyl pentane. In the more complex molecules, it becomes necessary to indicate the position of the carbon atoms to which the various groups are attached. Iso-octane, one of the reference fuels for knock testing, is more accurately referred to as 2, 2, 4-trimethylpentane. Its structure is shown in Fig. 112.

Olefins are unsaturated paraffins. They may be formed by "breaking" the chain of a paraffin molecule into two parts (see Fig. 113). This is what occurs when a gasoline is "cracked." Since the right-hand fragment of the broken molecule lacks two hydrogen atoms of the number necessary to form a paraffin,

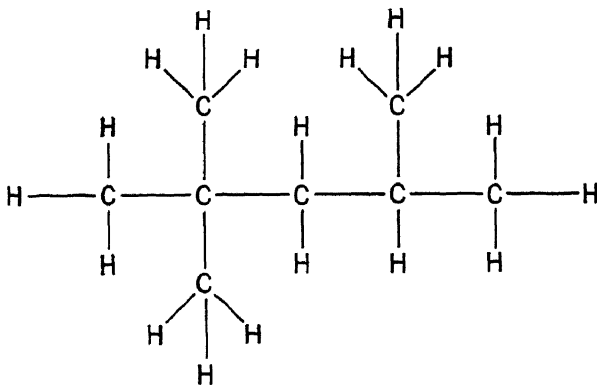

FIG. 112.—Iso-octane, more accurately called 2,2,4-trimethylpentane.

a double bond is formed between the two carbon atoms. This double bond distinguishes it from its paraffin counterpart. The term *unsaturated* used above indicates this difference. Under suitable conditions, this unsaturated hydrocarbon can take on two atoms of hydrogen to become saturated, *i.e.*, an ordinary paraffin. Such an addition of hydrogen is called *hydrogenation*.

The olefins are called by names similar to those given the corresponding paraffins, the distinction being that the ending is

changed from *ane* to *ylene*, e.g., *ethylene*, *propylene*, *butylene*, etc. The various isomers may be designated by the Geneva system in the same manner as the paraffins.

The naphthenes, sometimes called *cycloparaffins*, are similar to the paraffins in many respects. In structure, however, they differ in that they are in the form of a ring instead of a chain; hence the prefix *cyclo*. Various theories as to the exact form of their structure have been advanced, most of them requiring a

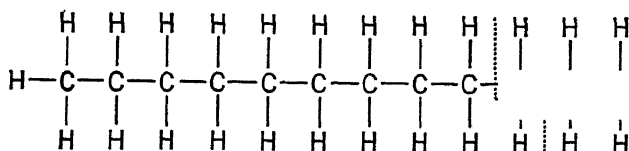

which gives

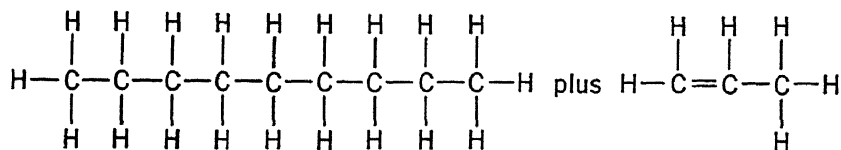

n-NONANE

PROPYLENE

FIG. 113.—Diagram showing the cracking of a paraffin to form a paraffin and an olefin.

three-dimensional representation. Some notion of their form, however, is given by Fig. 114, which shows a molecule of cycloheptane. Molecules having six, seven, eight, and more atoms of carbon have a similar form, the general formula for the series being the same as that for the olefins, C_nH_{2n} . The cycloparaffins differ from the olefins in that they are saturated, for the ends of the paraffin chain are joined so that there are no double bonds between carbon atoms as in the olefins. The cycloparaffins are less stable than the paraffins, as the ring is rather easily broken. As in the paraffins, many isomers exist. Their number is also accurately predicted by theoretical considerations.

The aromatic hydrocarbons are a family of compounds whose basic structural unit is the benzene ring, shown in Fig. 115. This representation in one plane appears to be accurate, although the stability of the ring itself indicates that the "double bonds"

between the carbon atoms are quite different from those in the olefins, and so the molecule must be considered saturated. The

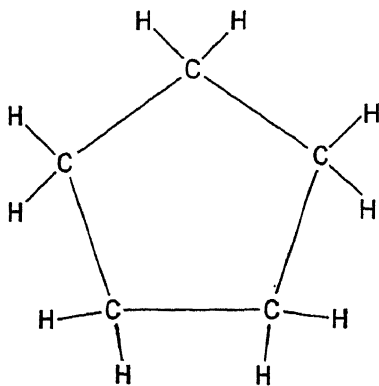

CYCLOPENTANE

FIG. 114.—Structure of a naphthenic hydrocarbon.

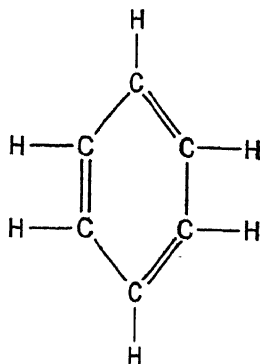

BENZENE

FIG. 115.—Structure of benzene, the simplest aromatic hydrocarbon.

more complex molecules consist of groups of benzene rings as shown in Fig. 116 or have various hydrocarbon groups taking the place of the hydrogen atoms. Isomers of the various benzene compounds occur just as in the previous groups.

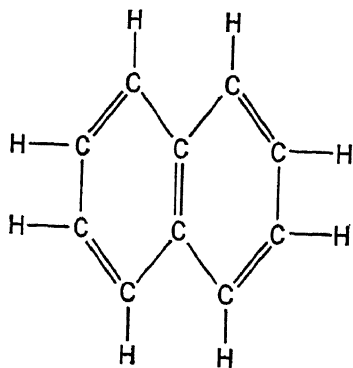

NAPHTHALENE

FIG. 116.—The structure of naphthalene.

Antiknock Characteristics.—

Fuels vary widely in their resistance to detonation in spark-ignition engines. The straight-chain paraffins are poor, and the longer the molecule the worse they become. Olefins are considerably better, but they also have progressively lower knock resistance as the length of the molecule is increased. Branched-chain paraffins (see Fig. 112) have greatly improved knock resistance, which increases with the

complexity of the branching. This seems to be due to the fact that the more highly branched molecules become increasingly more compact in structure. Naphthenes have good resistance to

detonation, while the aromatics are excellent if the combustion-chamber and mixture temperatures are kept low. With high cylinder-head and/or mixture temperatures the aromatics are strongly inclined to preignite (see Figs. 43 and 44, page 67).

PETROLEUM REFINING

Distillation and Fractionation.—The innumerable constituents of a crude oil may be separated into groups of different boiling points. Products having very nearly the same boiling points can be separated by passing them up through a fractionating tower filled with trays each of which is kept at a constant temperature somewhat lower than the temperature of the tray immediately beneath it. The distillate is passed up through the tower in such a way that it must bubble through the liquid in each tray. In this way, each "fraction" in the distillate tends to condense out in the tray having a temperature just below its boiling point. This sort of separation was practically the only operation carried out in refineries until the First World War. It is still the most important process used.

Cracking.—Since only a relatively small portion of a crude oil has the proper volatility for a satisfactory gasoline, the increasingly heavy demand for motor fuel made necessary the development of methods for "cracking," or breaking up, the heavy molecules in the portion left over after the volatile gasoline had been removed. Tremendous advances have been made in petroleum refining since 1932, especially in respect to cracking. Many different processes are in use. The older methods depend upon high temperatures and high pressures to crack the heavy molecules, while many later processes make use of various catalysts.

Fuels obtained from cracking stills are referred to as *cracked* gasolines in contrast to *straight-run* gasolines obtained simply by straight distillation of the crude. The cracked gasolines contain relatively large percentages of olefins.

Synthesis of Fuels.—Light gases obtained from the crude or from the cracking still may be combined to form heavier molecules of certain types, notably the branched-chain paraffins, to provide fuels of exceptionally high antiknock value. The processes used generally depend on temperature, pressure, and a catalyst to bring about the combination, or "polymerization," of molecules

containing three or four atoms of carbon to form branched-chain paraffins having seven or eight molecules of carbon.

A process called "catalytic alkylation" may be used to combine butylene and isobutane in the presence of a catalyst to form iso-octane, one of the most knock-resistant fuels known. The reaction is generally carried out at temperatures of about 40°F with sulfuric acid as the catalyst.

In some processes, catalytic cracking and polymerization are carried out at the same time with the same catalyst. Processes of this type convert a high percentage of the charging stock to a fuel having good antiknock characteristics.

Olefins formed in the cracking processes tend to be unstable and oxidize to form gums. To prevent this, they may be hydrogenated to give more desirable fuels.

Solvent Extraction.—Selective solvents may be used to separate aromatics, naphthenes, and paraffins. The method is particularly applicable to the refining of lubricating oil. A fraction of the crude from the correct boiling-point range can be processed with a solvent such as sulfur dioxide to leave an essentially paraffinic oil.

Wax can be removed from an oil by mixing it with a solvent and chilling. The wax can be filtered off and the solvent evaporated from the filtrate to leave a wax-free oil. Acetone and benzol are two of the solvents used for dewaxing.

Purification.—A large part of the impurities in a crude oil are eliminated by distillation; but some, either from the crude or from some phase of the refining operation, may remain to cause service difficulties. The purification treatment used depends on the material to be removed. Sulfuric acid is sometimes employed to remove resinous materials that would cause objectionable engine deposits. The acid, in turn, may be removed by washing. An alkali is sometimes used to complete the removal of the acid. Filtration through either untreated or treated clay will eliminate suspended matter and some objectionable compounds.

Additives.—Special compounds are added to both fuels and oils to give improved characteristics. The stability of cracked gasolines containing considerable amounts of olefins can be greatly improved in this way. Tetraethyl lead is almost universally added to give improved detonation resistance. Lubricants

can be given improved resistance to oxidation, better low-temperature characteristics, and better detergent properties by the addition of relatively small amounts of certain compounds. These additives will be discussed at greater length in subsequent pages.

Refinery Flow Sheet.—Figure 117 gives a flow sheet indicating how a crude oil may be refined in the production of aviation fuels and lubricants. It is not intended to represent a typical refinery but rather shows how the specialized processes of producing high-octane aviation gasoline are related to other phases of refining. All the more common methods of producing high-octane blending agents are included in this diagram, although only one or two would be found in an actual refinery. The steps in the production of fuels are indicated across the top of the figure. It is interesting to note that many of the plant units represented in the upper center are equally well suited to the production of the ingredients of synthetic rubber.

OCTANE RATING OF FUELS

Significance of Octane Numbers.—The ability of a fuel to resist detonation is a complex characteristic difficult if not impossible to express in terms of ordinary units. An arbitrary test procedure based on the relative antiknock values of iso-octane (very high) and of normal heptane (relatively low) has been the only standard to be generally accepted. The test procedure has been to test an unknown fuel whose antiknock value was to be determined in a specific single-cylinder engine and then to determine the proportions of a mixture of iso-octane and heptane that would give the same resistance to detonation. The percentage of octane in the equivalent mixture is the antiknock value, or *octane number*, of the fuel.

Test Methods and Equipment.—As was pointed out in the chapter on Combustion, the detonating characteristics of a fuel are to a considerable extent a function of the operating conditions and of the engine in which the test is conducted. The various fuel-rating tests in current use each specify a single-cylinder engine of a particular model, the crankshaft rpm, the fuel-air mixture inlet temperature, a temperature indicative of that of the combustion chamber, the spark advance, and other factors affecting the detonation characteristics of a fuel. Three tests

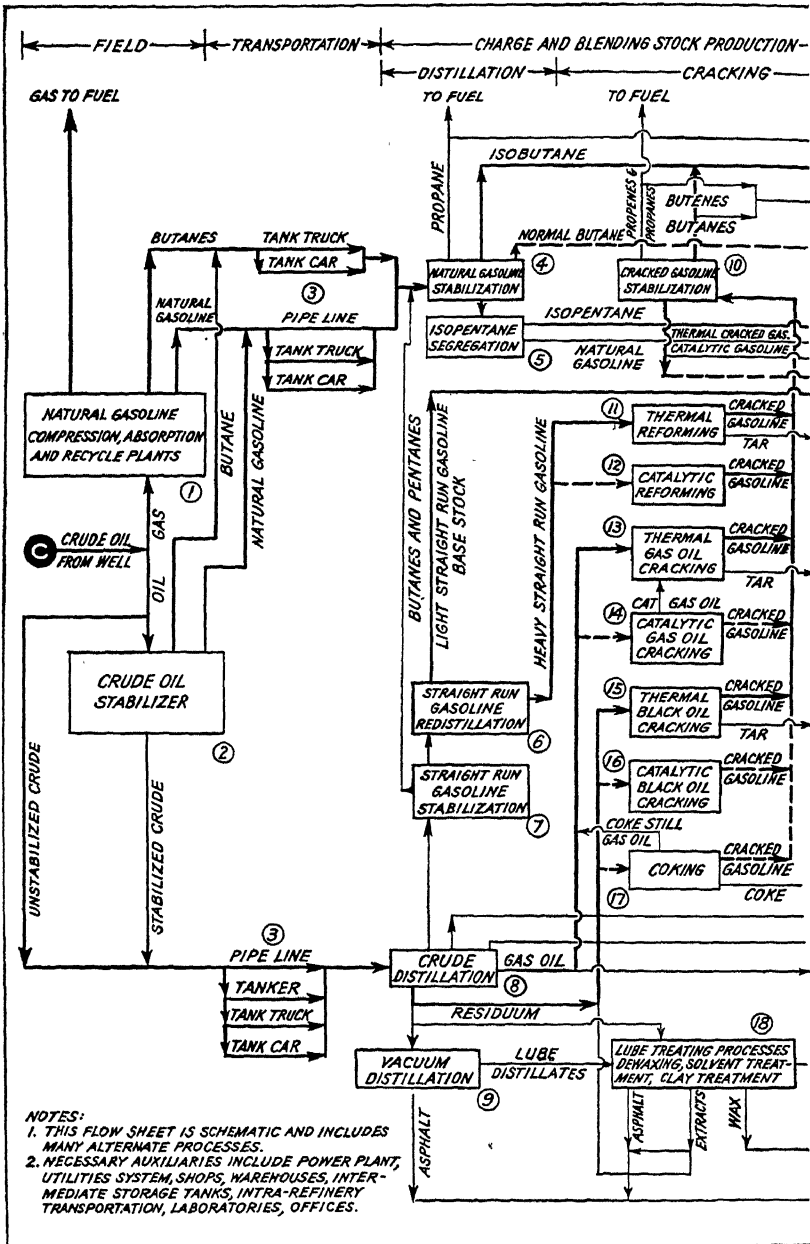
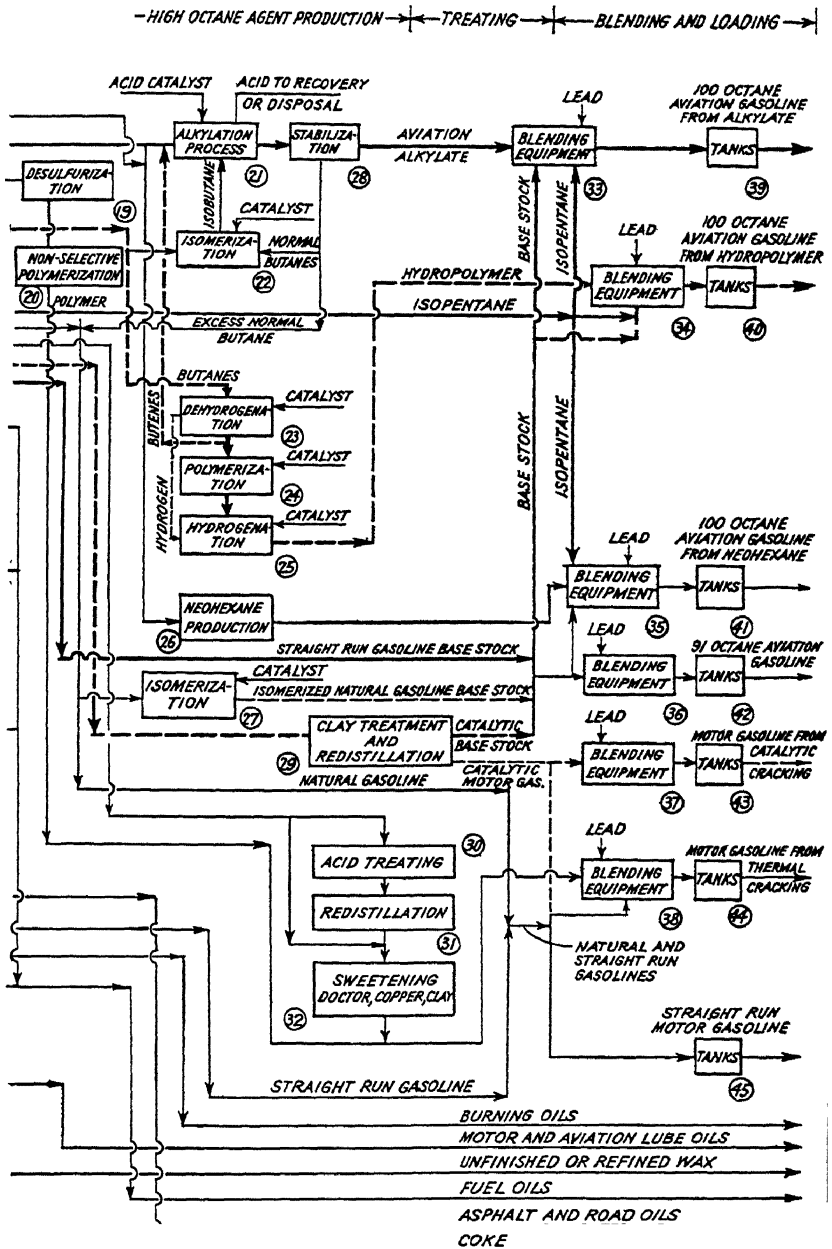

FIG. 117.—Flow sheet showing refining processes widely used in the



production of aviation fuels and lubricants. (Office of Petroleum Coordinator.)

that have been widely used are listed in Table IV, together with the principal items specified in each.

TABLE IV.—COMPARISON OF KNOCK-TESTING METHODS

Method	British Air Ministry	U.S. Army	A.S.T.M.
Engine.....	Waukesha	Waukesha	Waukesha
Cylinder diameter, in.....	3¼ (82.5 mm)	2½ (66.7 mm)	3¼ (82.5 mm)
Intake valve.....	Plain	Plain	Shrouded
Speed, rpm.....	900	1,200	900
Jacket temperature, °F.....	212 (100°C)	300 (149°C)	212 (100°C)
Manifold heat, °F.....	260 (127°C)	None	300 (149°C)
Spark advance, deg.....	26 (at 5:1 compression)	30 (constant)	26 (at 5:1 compression)
Mixture ratio.....	Maximum knock	Maximum knock	Maximum knock
Knock detector.....	Bounding pin	Temperature plug	Bounding pin

TABLE V.—ANTIKNOCK PROPERTIES¹

Fuel type	A.S.T.M.	B.A.M.	Army
Straight-run gasoline.....	77 max.	78 max.	77 max.
Cracked gasoline (pyrolytic).....	65-80	65-80
Catalytically cracked gasoline.....	76-79	About 79 max.	75-78
2,2,4-trimethylpentane.....	100	100	100
Commercial mixed iso-octanes.....	95-99	95-99
Isopentane.....	About 90
Diisobutylenes (olefins).....	84	84
Cyclohexane.....	75
Benzene.....	100 + 0.6 cc approx.	88
Toluene.....	100 + 2.0 cc approx.	98
Methyl alcohol.....	98	87-90
Ethyl alcohol.....	99
Acetone.....	100	100
Diisopropyl ether.....	98-99

Table V shows something of the effect of the various test methods on the octane rating that would be given to the same fuel. It must not be forgotten that a fuel-rating test is a purely relative affair, and a reference fuel must always be used. The characteristics of the reference fuel may be such that its anti-

knock value changes with, say, cylinder-head temperature to a much greater extent than the antiknock characteristics of the fuel being rated, or vice versa. Speed, and especially imep, may also cause variations in the relative antiknock values of two fuels. The effects of these factors were discussed in the latter part of Chap. IV.

Effect of Fuel-Air Ratio.—One of the most common methods to inhibit detonation to permit operation at a higher bmep than would otherwise be possible is the use of a fuel-air mixture considerably richer than that giving the greatest power at a given manifold pressure and speed. It may be recalled that power-enrichment devices in carburetors are intended for this purpose and that the enrichment they provide may amount to nearly 100 per cent of the best economy fuel-air ratio. Various fuels display different susceptibilities to mixture enrichment. With some types the use of a richer mixture at high bmep's may have little effect on the antiknock characteristics of the mixture, while with others a very marked increase in the apparent antiknock value of the fuel may be realized. This greatly increases the difficulty encountered in fuel-rating work; for the tests conducted on single-cylinder engines are normally made only with the maximum knock mixture, while full-scale engines are greatly affected by the fuel knock characteristics at rich mixture. Fortunately, most American aviation fuels consist primarily of similar hydrocarbons so that a fairly constant relationship exists between single-cylinder and full-scale engine tests. The mixture susceptibility of paraffins is fairly good, as is indicated by Fig. 45, though that of the aromatics is much greater.

Effect of Tetraethyl Lead.—The antiknock value of a fuel may be increased by the addition of any one of a number of detonation suppressants, the most important of which is tetraethyl lead. Very small quantities of this compound result in markedly increased octane ratings for most gasolines, as indicated in Fig. 118. Thus, at a relatively low cost, a gallon of fuel may be given a much higher antiknock value by the addition of a few cubic centimeters of tetraethyl lead. It can also be seen from Fig. 118 that the amount of tetraethyl lead required to obtain a given improvement in octane rating increases very rapidly with the addition of tetraethyl lead, so that about 6 cc per gal. represents the economically practical limit.

Economy is not the only factor that imposes a limit on the "leading" of fuels, for the use of tetraethyl lead has a number of disadvantages. The products of combustion from a leaded fuel are highly corrosive and attack most metals. When an engine cools after operation, moisture tends to condense and form droplets on the combustion-chamber walls. The lead compounds present dissolve in this water to make a corrosive solution that tends to attack aluminum pistons and steel cylinder walls and leave pits that may become quite serious. It is for

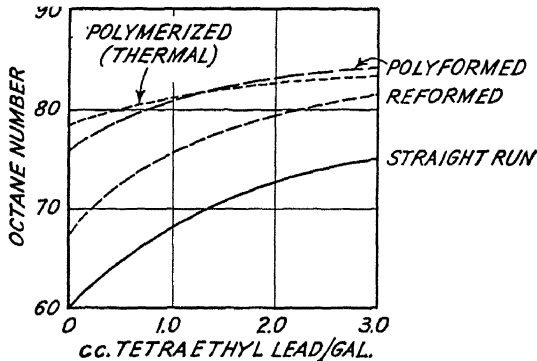

FIG. 118.—Effect of tetraethyl lead on the octane rating of several different types of fuels. (Socony-Vacuum Oil Co.)

this reason that engines are commonly "run out" on "clear" (unleaded) fuel before stopping them at the end of a run-in after which they are to be stored or packed. The corrosive action of lead in the products of combustion has been greatly reduced by adding special compounds, such as those in tetraethyl lead fluid. Deposits on the cylinder head and piston also help somewhat to protect these parts after the engine has been in operation for 50 hr or more. The high temperature of the exhaust valve during operation makes it particularly susceptible to "hot" corrosion. Development of corrosion-resisting steels has reduced trouble of this sort.

If more than 3 cc of lead per gallon of fuel is present, difficulty with lead deposits in the engine may become serious. These may build up on the spark plugs to cause "lead fouling" or on the pistons or cylinder heads to cause hot spots which increase the likelihood of detonation, or they may pass the piston rings and form deposits in the crankcase and thus enter the lubricating

oil. They may also attack and corrode the valves when hot and deposit on the valve stems to cause the latter to stick in the guides.

Fuels vary in their *lead susceptibility* (see Fig. 118). The octane number of paraffins is readily improved, while that of olefins, naphthenes, and aromatics is improved relatively less by the addition of tetraethyl lead.

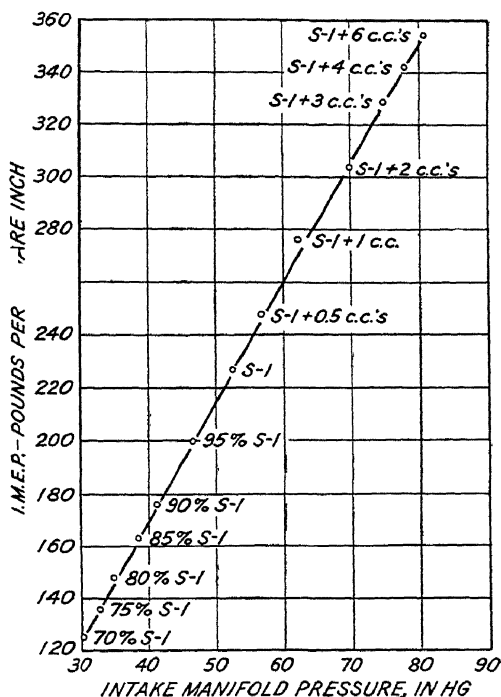

FIG. 119.—Maximum imep without detonation plotted against map for different mixtures of fuels. (Heron and Beatty, *Jour. I.A.S.*, Vol. 5, No. 12, October, 1938.)

Extrapolation of the octane scale for fuels having a higher knock resistance than 100-octane may be made on the basis of a number of different methods, each of which will yield different ratings. The most satisfactory method at the time of writing is to determine the amount of tetraethyl lead that must be added to iso-octane to make it equivalent to the test fuel.

Effect of Octane Number on Engine Performance.—Since engine power output is directly proportional to the intake manifold pressure, the amount of supercharging that can be safely

used represents a good criterion for the effect of fuel octane number on full-scale engine performance. Figure 119 shows the imep obtained plotted against the manifold pressure limited by detonation for each of a series of fuels. Standard reference fuels S-1 and M-1, which are the commercial equivalents of iso-octane and normal heptane, respectively, were used. The percentage of S-1 in M-1 is indicated on the lower part of the curve, while the

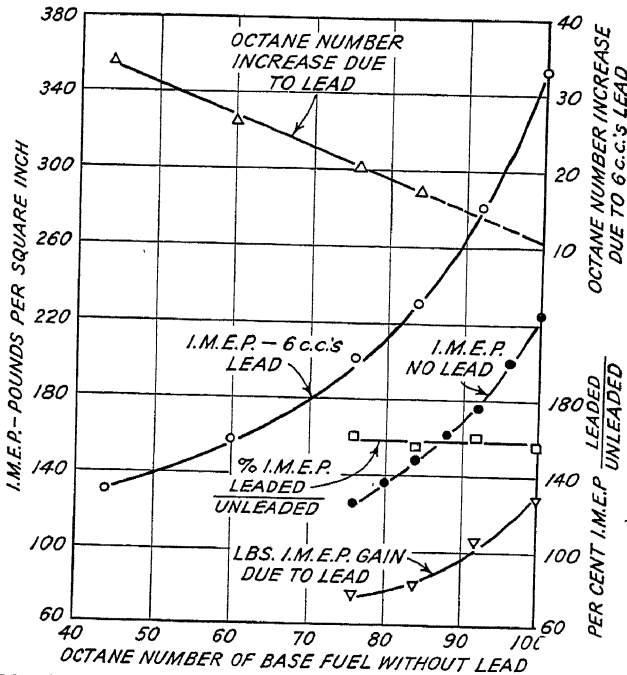

FIG. 120.—Effect of the octane rating of the fuel used on the maximum imep obtainable without detonation. (Heron and Beatty, *Jour. I.A.S.*, vol. 5, No. 12, October, 1938.)

amount of tetraethyl lead in 100 per cent S-1 is given on the upper part. Since the power that may be obtained from a given engine is roughly proportional to the imep, the value of increased detonation resistance is immediately evident.

Fuel octane numbers are not directly proportional to the maximum permissible imep. This is shown in Fig. 119 and, more clearly, in Fig. 120. The sharp rise in the curve for values of more than 90 octane numbers for the base fuel shows the great returns which can be expected from fuel improvements in that range.

PHYSICAL AND CHEMICAL TESTS ON FUELS

Volatility.—One of the most important properties of a fuel is its volatility. If this is sufficiently high, a combustible mixture may be formed even at low temperatures in a cold engine and the engine can be started easily. On the other hand, high-altitude flight calls for operation at absolute pressures of as low as 8 in. Hg. Since the boiling point of fuel drops off rapidly with pressure, too volatile a fuel will boil off at high altitudes. As a matter of fact, before the air pressure drops enough to cause boiling, large bubbles of vapor tend to appear in the fuel lines to cause vapor lock in the fuel pump and interruption of the fuel supply to the engine. This problem will be discussed in the chapter on fuel systems.

The volatility of a fuel may be expressed in a number of ways. One of the most complete methods is to give it in terms of the percentage distilled at each of several temperatures. The temperature at which 10 per cent will be distilled off is one of the best indications of the starting characteristics of the fuel; the temperature at which one-half the fuel is distilled off is a good mean of the over-all characteristics; while the point at which 90 per cent of the fuel is distilled off when compared with the other two values gives an indication of the ease with which virtually all the fuel can be vaporized. The latter is particularly important from the standpoint of *distribution*, *i.e.*, the uniformity of the fuel-air ratio in the mixture delivered to each of the several cylinders. Incomplete vaporization of the fuel tends to cause the liquid portions that are in the form of small droplets in the induction system to be separated from the main body of the charge in passing through irregularities in the induction system, such as around corners where a centrifuging action occurs. This segregation of the fuel causes some cylinders to operate with a richer mixture than others and, where the heavier constituents in a gasoline are of a different octane value than the lighter, may cause a pronounced difference in the antiknock characteristics of the fuel from one cylinder to another.

Figure 121 shows a typical distillation curve for an aviation gasoline. Note that the curve is relatively flat, which indicates that the fuel has the desirable characteristic of a comparatively uniform boiling point. Figure 121 also gives an idea of the

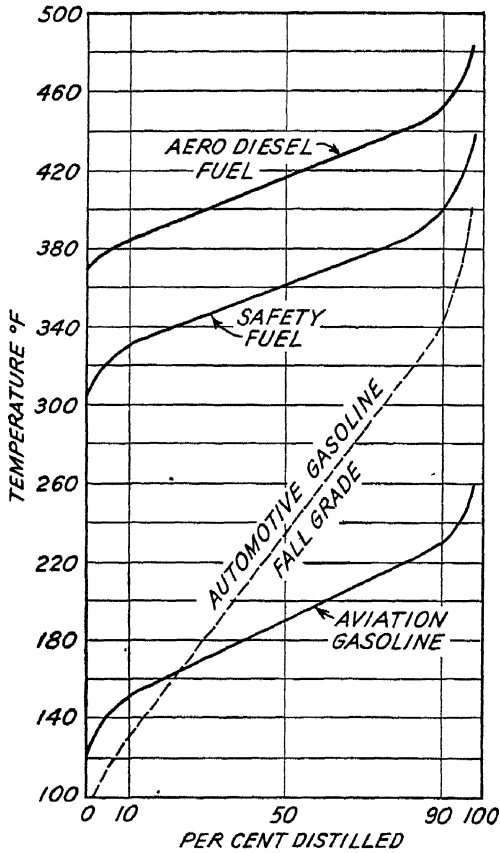

Fig. 121.—Distillation curves for several fuels of different types. (The Texas Co.)

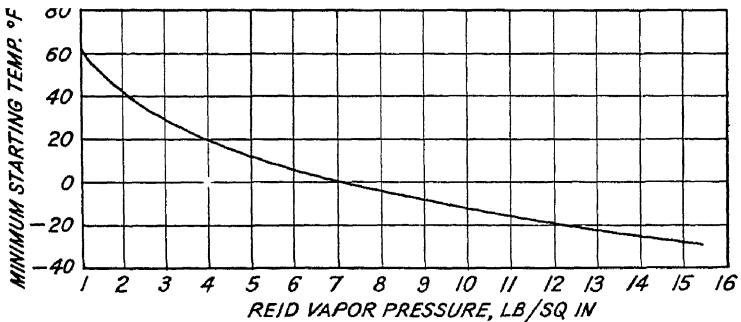

Fig. 122.—Effect of Reid vapor pressure on minimum starting temperature. (Bridgeman, S.A.E. Trans., vol. 49, 1941.)

volatility of several other fuels as it shows the distillation curves for automobile gasoline and an aviation diesel fuel.

The vapor pressure of the fuel is also usually specified for it gives a better indication of the starting characteristics, the tendency of the fuel to vapor-lock, and the amount of evaporation loss to be expected. The vapor pressure is normally measured according to a specified standard procedure that gives a value called the *Reid vapor pressure*. The method depends on the pressure generated when a bomb containing fuel and air is closed at 40°F and then heated to 100°F. The pressure increase in pounds per square inch gives the Reid vapor pressure. A maximum limit of 6 or 7 psi is usually set for this value. Figure 122 shows the minimum starting temperature as a function of vapor pressure for fuels of different volatility.

Freezing Point.—High-altitude work also entails operation at low temperatures. Any tendency toward freezing or the formation of crystals at temperatures as low as -50°F cannot be tolerated, for it might cause clogging of filters and interruption of the fuel supply to the engine. Benzol has the undesirable characteristic that it tends to form crystals at low temperatures. This consideration makes it necessary to restrict the amount of benzol in a fuel to about 20 per cent to prevent freezing difficulties down to -50°F . Aviation gasolines generally have no tendency to crystallize or freeze until they reach temperatures considerably lower than this value.

Specific Gravity.—Since large quantities of fuel are carried on long flights, the specific gravity may be important for it determines the tank capacity required. Changes in the specific gravity of a fuel used in a given airplane also affect the carburetor setting and the fuel flowmeter if one of the latter is used. Although an exact value for the specific gravity is ordinarily not prescribed, specifications usually require that it be measured.

Gum.—Unsaturated hydrocarbons present in cracked gasolines tend to oxidize to form gums that are insoluble in gasoline. These may precipitate out to clog strainers, valves, and parts of the carburetor. The tests that have been used to determine the amount of gum in a fuel involve the evaporation at a controlled rate of a fuel sample in a polished copper dish. A number of tests intended to indicate the tendency of a fuel to form gum during long periods of storage have been applied. Heated

air may be bubbled through the fuel in such tests to accelerate gum formation.

Corrosion.—Sulfur in the form of mercaptans, hydrogen sulfide, or finely divided free sulfur may be present in a fuel either

TABLE VI.—COMMERCIAL AVIATION GASOLINE SPECIFICATIONS USED BY DOMESTIC AIR LINES³

Name	ASTM-73	ASTM-80	ASTM-87	ASTM-90	ASTM-95
Octane number, A.S.T.M. Motor Method, min.	73	80	87	90	95
Tetraethyl lead, ml per gal, max.	None	2.0	3.0	4.0	4.0
Tetraethyl lead, ml per gal, min.				3.5	3.5
Color, Saybolt.	+28	Blue	Blue	Blue	Blue
Doctor.	Negative	Negative	Negative	Negative	Negative
Corrosion, copper strip at 212°F.	No	No	No	No	No
Corrosion, copper dish.	No	No	No	No	No
Gum, copper dish, mg per 100 ml, max.					
Gum, accelerated, mg per 100 ml, max.	6	6	6		6
Sulfur, per cent, max.	0.05	0.05	0.05	0.05	0.05
Distillation, temperature, °F., of					
10 per cent evaporated, max	158	158	158	158	158
50 per cent evaporated, max	212	212	212	212	212
90 per cent evaporated, max	257	257	257	257	257
End point shall not be higher than.	311	311	311	311	311
Recovery, per cent, min.	97	97	97	97	97
Residue, per cent, max.	1.5	1.5	1.5	1.5	1.5
Loss, per cent, max.	1.5	1.5	1.5	1.5	1.5
Sum of 10 per cent and 50 per cent, min.	307	307	307	307	307
Reid vapor pressure at 100°F lb per sq. in., max.	7.0	7.0	7.0	7.0	7.0
Acidity of residue after distil- lation.	Neutral	Neutral	Neutral	Neutra	Neutral

from the crude or from some phase of the refining. Specifications generally give a maximum sulfur content as well as a corrosion test. The latter requires that a polished copper strip or dish be left undischored after contact with heated fuel for a specified period.

Mercaptans or hydrogen sulfide in the fuel causes an objectionable odor. The "doctor test" is generally specified because it is particularly sensitive to these compounds. The results of the test are usually given as "sweet" or "sour."

Fuel Specifications.—Rather complicated specifications have been set up for aviation fuels. A summary of these is given in Table VI. Note that, in addition to the tests described in the preceding pages, other tests, including those for color, water, sediment, and specific heat, are required to ensure the quality of the fuel.

PHYSICAL AND CHEMICAL TESTS ON OILS

The oil in an aircraft engine has several functions and must meet varying and sometimes almost diametrically opposed demands. It must lubricate shafts rotating in bearings and the cylinder walls and pistons. Since the pistons in an air-cooled engine run at about 400°F, the oil also serves as a coolant to keep the dome of the piston within allowable temperature limits. If excessive oil consumption is to be prevented, the cylinder walls must operate with only a very thin film of oil between them and the piston. Even this film is exposed to the high temperatures and oxidizing effects of combustion. The oil must be heavy or viscous enough to support the extremely high bearing loads between the master-rod bearing and the crankpin and at the same time be thin enough to permit starting in cold weather. It must be noncorrosive so that it will not attack the different bearings and other alloys with which it comes in contact. The latter is a particularly difficult requirement because the oxidizing conditions to which the oil on the cylinder walls is subjected tend to cause the formation of organic acids that attack many of the bearing metals.

Many different laboratory tests have been devised to determine the suitability of a lubricating oil for a given application. Most of the important tests are used to control the uniformity of an oil. No test other than actual service has been devised to show which of two similar oils is the better—the laboratory tests in use simply make possible the selection of lubricants that are likely to do a good job in a particular application.

Viscosity.—Probably the most important characteristic of a lubricating oil is its *viscosity*. This property is generally meas-

ured with a viscosimeter in which the oil is allowed to drain through an orifice. The time required for a given amount to flow is taken as the measure of its viscosity. The Saybolt universal viscosimeter is the unit most commonly used for lubricating oil in this country, the viscosity obtained with it being given in *Saybolt universal seconds*. The S.A.E. viscosity scale is approximately the latter value divided by 2. Thus, 120-sec oil, that used in most aircraft engines, would have an S.A.E. viscosity of 60, while the oil for most automobiles is about 30 on the S.A.E. scale.

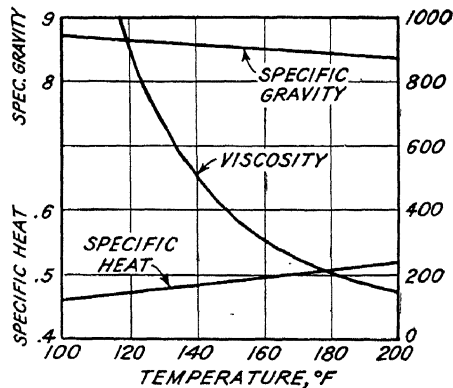

FIG. 123.—Effect of temperature on the viscosity, specific gravity, and specific heat of a typical aircraft engine oil. (*Caminez, I.A.S. Jour.*, vol. 1, No. 3, 1934.)

The viscosity of an oil changes rapidly with temperature, as shown in Fig. 123. A convenient set of logarithmic coordinates has been devised on which the viscosity-temperature curve for an oil will plot as a straight line. Figure 124 shows a chart of this type. Viscosity measurements must be taken at a specified temperature, usually 100 or 210°F.

The viscosity of lubricating oils is usually determined at 100°F for the lighter oils and at 210°F for the heavier oils. It happens that two oils having the same viscosity at 100°F do not, in general, have the same viscosity at 210°F. Since it would be desirable to have the viscosity of a lubricating oil remain constant regardless of temperature, the less the change in viscosity from 100 to 210°F, the better the oil as a lubricant. A rather arbitrary scale has been set up to serve as a measure of this change in viscosity. Since paraffin-base oils show less change in viscosity with temperature than naphthenic oils, the

viscosity index of an average paraffinic oil has been taken as 100 while that of an average naphthenic oil was made zero. Thus the viscosity index of an oil may be defined as the relation

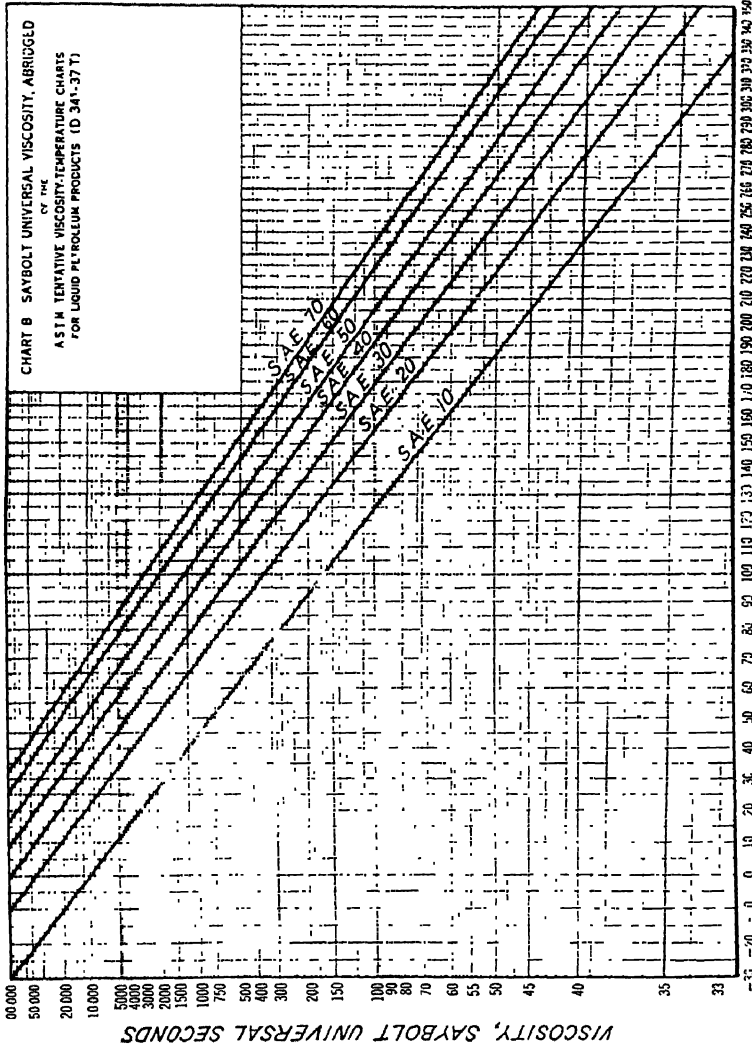

Fig. 124.—Viscosity-temperature curves on standard logarithmic-type chart. (Matli and Kavanagh, S. A. E. Trans., vol. 36, 1941.)

its Saybolt universal viscosity at 100°F bears to the viscosities of an average paraffinic oil and an average naphthenic oil at the same temperature if all three have the same viscosity at 210°F. Thus an oil having a viscosity at 100°F, which is mid-

way between that of the "standard" paraffinic oil and that of the "standard" naphthenic oil, would have a viscosity index of 50 if all three had the same viscosity at 210°F. The scale can be extrapolated to describe oils having a viscosity index of more than 100. If specifications call for a high viscosity index, the refiner either must start with a good crude or must undertake a more expensive and complete refining process.

Pour Point.—The *pour point* of an oil is the temperature at which it becomes too viscous to flow. A well-defined point, it is of value in determining the cold-weather starting characteristics of an oil—the lower the pour point, the lower the temperature at which the engine may be readily turned over with the starter.

Specific Gravity.—The specific gravity of an oil is also an important characteristic and should be determined. In this country, the property is often expressed in degrees A.P.I. (American Petroleum Institute). The latter units are inversely proportional to the specific gravity, the relationship being

$$\text{A.P.I. degrees at } 60^{\circ}\text{F} = \frac{141.5}{\text{specific gravity at } 60^{\circ}\text{F}} - 131.5 \quad (33)$$

The specific gravity of an aircraft-engine oil is given in Fig. 123. Since this characteristic varies as much as about 7 per cent with the source of the crude from which the oil was distilled, the values given should not be taken as having general application.

Emulsification of Water.—The tendency of an oil to emulsify water and carry it in suspension is measured by mixing oil with distilled water and then letting the mixture stand. The time required for the water to separate from the suspension is a measure of the *demulsibility*. The emulsifying characteristics of an oil are of importance because they are indicative of the tendency of an oil to deposit sludge in the oil lines and cause foaming in the tank and similar troubles.

Centrifuge Tests.—The *precipitation number* of an oil is a measure of the amount of water and solids it carries in suspension. It is applied principally to used oils. The suspended matter is centrifuged out under a force about 500 times that of gravity. Figure 125 shows three centrifuge tubes with samples of different used oils. There should be no water or sediment in an oil received from the refiner—the presence of either indicates poor storage or handling. Both can be separated out by means of a centrifuge.

Neutralization Number.—Acid or alkali may be left in a new straight mineral oil if it is not properly refined. Petroleum oils may also contain naphthenic acids, which should be removed in the refining process. Since they are an oxidation product, they invariably begin to form in an oil after even a few hours of

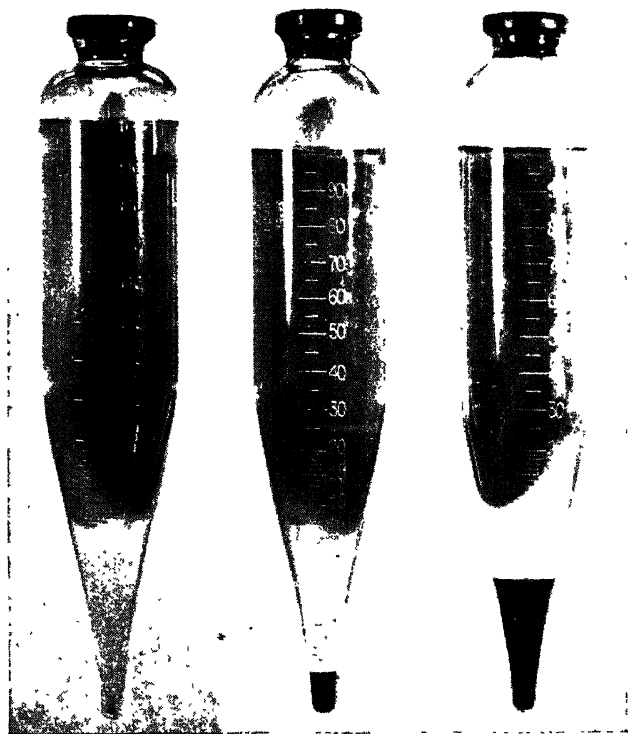

FIG. 125.—Centrifuge tubes showing samples of several different oils after use. (Wright Aeronautical Corp.)

use in an internal-combustion engine. A source of acidity in compounded oils is the organic acids always associated with vegetable and animal oils. Such oils will cause corrosion if they contain free fatty acids, which tend to form as decomposition products.

The acidity of an oil may be expressed in terms of its *neutralization number*, *i.e.*, the weight in milligrams of potassium hydroxide required to neutralize 1 gram of the oil. It is a measure of the total amount of mineral and organic acid present. When applied to new oils, the test for acidity indicates how well the

oil has been refined. On used oils, it indicates the deterioration of the oil in service.

Oxidation.—A number of different tests have been devised to measure the resistance of oil to oxidation. The usual method is to heat the oil to a prescribed temperature for a stipulated time during which it is exposed to the action of either pure oxygen or air. It is then diluted with naphtha and filtered. The residue, largely asphaltenes, is weighed and the *oxidation number* of the oil expressed in terms of the number of milligrams of residue per 10 grams of sample. This gives some indication of the resistance of the oil to oxidation and to the formation of sludge. The problem is complicated by the fact that emulsifying agents may be present in the oil and thus may keep the sludge in suspension.

Carbon Residue.—Another indication of the tendency of an oil to form sludge is given by the amount of carbon residue left after destructive distillation. A sample is heated slowly within a carefully vented system of crucibles until nothing is left but carbon. Some oils leave virtually no residue, while others tend to break down to leave a considerable amount. Oils in the latter class have a greater tendency to leave deposits, which are particularly objectionable on pistons and piston rings. Such deposits may also cause valve sticking and the clogging of oil passages.

Sulfur.—Sulfur in the free or the combined form is generally undesirable in lubricating oils. It may come from the crude, or it may be added to the oil during refining operations. The chemical analysis for the total amount of sulfur presents a complex laboratory task because of the many organic compounds present and the different forms in which the sulfur may occur. It is usually required, however, for it gives the best measure of the harmful effects likely to be caused by the sulfur.

Corrosion tests on oils are made to give an indication of the tendency of the oil to attack bearing surfaces. The usual method is to heat a sample of the oil in which a polished strip of copper has been immersed. If the copper is still bright and free of pits after the test, the oil is considered free of corrosive compounds. Sulfur is the agent most likely to cause discoloration.

Flash and Fire Points.—The flash point is the lowest temperature at which oil gives off vapor to such an extent that, when air is present, the vapor will flash, or burn momentarily, when a small

flame is introduced. The fire point is the lowest temperature at which the oil will give off vapor that will continue to burn steadily. Both tests, particularly the former, are used to check oil from the standpoint of storage fire hazard.

Engine Tests.—No test other than actual operation has been successful in rating an oil for aircraft-engine use. The Wright Aeronautical Corporation set up an oil approval test in 1936 that was found to be a good all-round comparative test for oils to be used in aircraft engines. In this test, the oil is subjected to 70 hr of endurance testing in a full-scale engine. The engine is run for 120 cycles consisting of definite periods at idle, take-off, and rated power. All conditions are controlled, and a complete set of data is taken. Oil samples are taken at regular intervals and checked for sludge, asphaltenes, and viscosity. The oil is then given a numerical rating based on engine operation during the test, the condition of the oil during and after the test, and of the engine after the test. Factors considered under the last item are piston-ring wear, master-rod bearing condition, and sludging in the engine.

SPECIAL PROBLEMS

Low-volatile Fuels.—The fire hazard attending the use of highly volatile aviation gasoline has led to the investigation of fuels having a lower volatility. The term *safety fuel* is often applied to fuels of this type. Their volatility is indicated by the distillation curve in Fig. 121.

There are a number of objections to low-volatile fuels. One is that the starting characteristics are so poor that an auxiliary fuel of high volatility must be supplied. Probably the most important objection is that the fuel must be injected directly into the combustion chamber, or at least into the intake parts, to give good distribution to the various cylinders. Other objections include poor fuel economy in the idle range and dilution of the lubricating oil by the "heavy ends" from the fuel. The latter do not vaporize well unless the engine is hot and hence tend to collect on the cylinder walls and drain into the crankcase.

Greases.—Greases are used to lubricate bearing surfaces if the frictional heat generated between the surfaces is small enough so that the resulting temperature rise will not be large. Some propeller-pitch changing mechanisms, certain accessories,

and, in some engines, the valves and valve gear are grease lubricated.

Greases are usually made by saponifying animal or vegetable oils with an alkali to form a soap, adding mineral oil, and working the mixture to the proper consistency. The properties of greases are complex. One item of interest is that at operating temperatures their viscosity is determined by the viscosity of the mineral oil of which they are made.

Dry Lubricants.—Graphite or sometimes a suspension of graphite in an oil or grease is used for some special applications, particularly where high temperatures make lubrication difficult. Graphite is especially good where the rubbing velocities are low, as in tachometer cables.

Lubricants are often used on spark-plug threads to prevent their seizing. A suspension of tiny mica flakes has been found to be excellent for this purpose.

References

1. HERON, S. D., and H. A. BEATTY: Aircraft Fuels, *Jour. I.A.S.*, vol. 5, No. 12, October, 1938.
2. FAUST, P. H.: Hydrocarbon Chemistry for the Refinery Worker, *Petroleum Refiner*, vol. 21, No. 8, August, 1942.
3. *Lubrication*, vol. 26, No. 9, September, 1940, published by The Texas Company.

CHAPTER XII

LUBRICATION, OIL FLOW, AND SCAVENGING

Oil is the lifeblood of the aircraft engine. If the oil supply to the bearings should cease, within a matter of seconds the lubricating films would break down to cause seizing, scoring, and burning of the vital moving parts. Fortunately, the engine oil pump and oil supply are dependable and, like the heart and circulatory system of the human body, quietly perform their function so well that we often forget their importance.

The problems related to aircraft-engine lubrication may be classified into a number of groups. The nature of the lubrication process and the theory of lubrication form an essential background. The actual lubricating-oil-system in the engine, including oil passages, oil tubes, pumps, and strainers, forms a somewhat complex but interesting study. The operating characteristics of this system, particularly the oil-flow and heat-rejection rates, provide the items of greatest interest to those concerned with the design of the engine installation in the airplane.

THEORY OF LUBRICATION

Types of Friction.—The most important objective of lubrication is to reduce friction. Friction has arbitrarily been classified as *dry friction*, *boundary friction*, and *fluid friction*. If two clean solid surfaces are rubbed together, they provide an example of dry friction. The coefficient of friction will run rather high, *viz.*, on the order of $\frac{1}{10}$ for metallic surfaces. The safe load-carrying capacity without danger of damage to the mating surfaces will be very low, *viz.*, on the order of 1 or 2 psi depending on the materials involved.

The other extreme, fluid friction, occurs when the two surfaces are completely separated by an oil film. Under these conditions, the friction is entirely fluid friction, and the coefficient of friction may be as little as 1/1,000 while the load capacity of the bearing surfaces may be as high as 8,000 psi without

damage to the mating surfaces. The latter value is the average pressure that may occur in the master-rod bearing of a radial engine if overspeeded during a dive. Even with high bearing loads, no wear will occur with perfect fluid friction, for the metallic surfaces are always separated by a film of fluid.

The type of friction intermediate between these two occurs when the surfaces have been covered with a film of oil, most of which has been wiped off. The resulting coefficient of friction, though it varies widely, is higher and the load capacity of the bearing surfaces lower than in the case of pure fluid friction. More or less rapid wear also characterizes this type of friction.

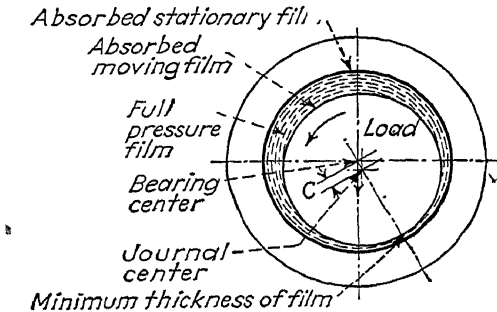

FIG. 126.—Journal rotating in a sleeve bearing. (Clower, "Lubricants and Lubrication," New York, 1939.)

The lubrication conditions that exist between the piston rings and the cylinder wall are the best example of this type of friction in aircraft engines.

Fluid-film Lubrication.—Lubrication of most of the parts in an aircraft engine is always of the fluid-friction type except during a start. Figure 126 shows a shaft in a bearing just as the former is starting to rotate. Boundary friction conditions exist between the shaft and the bearing. As soon as the shaft begins to rotate at an appreciable speed, however, the viscosity of the oil clinging to its surface causes a portion of the fluid filling the space between the shaft and the bearing at the top to be dragged along with the shaft. This forms a fluid wedge, which forces itself between the shaft and the bearing so that it lifts the shaft off the bearing by a small amount and gives a condition of true fluid friction. Thorough physical and mathematical investigations of this sort of lubrication have been made. Calculated results based on the viscosity of the lubricant, the

diameter of the shaft, its clearance in the bearing, and the speed of the shaft have agreed closely with measurements made of the load capacity and resultant minimum fluid-wedge thickness for journal and other types of bearing. Figure 127 shows the pressure existing in the oil film between the rotating journal and the bearing in a particular case. Capillary leakage from the high-pressure region through the space between the journal and

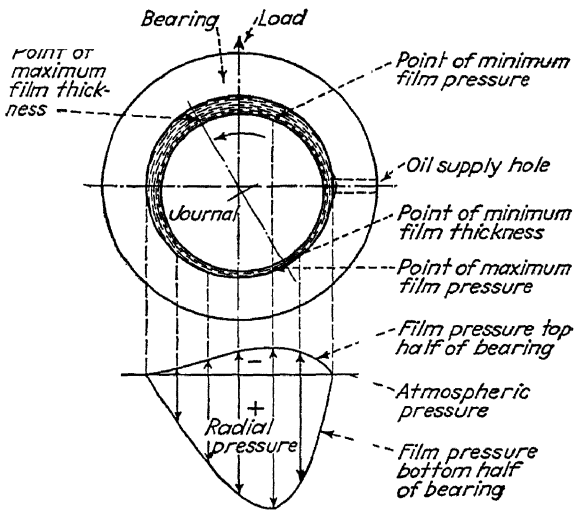

FIG. 127.—Pressure distribution across a sleeve bearing when running. (Clower, "Lubricants and Lubrication," New York, 1939.)

bearing and thence to the ends of the bearing occurs at a rate equal to that at which fresh lubricant is drawn in by the surface of the rotating shaft. It can also be seen in Fig. 127 that the journal is slightly displaced from the "at-rest" position by the fluid wedge.

If properly designed, such a bearing may be at least equal in load-carrying capacity and efficiency to any of the antifriction ball- and roller-bearing types. It has the disadvantage, however, that boundary friction exists on starting. If the loads are high, this may be a serious objection.

A number of facts have been deduced from the hydrodynamic theory of lubrication and have been substantiated by actual test. These include the effects of viscosity, the surface roughness of the bearing, the quantity of oil flow required, and the location

and shape of the oil supply channels. The load that a bearing will support is directly proportional to the viscosity of the oil. Aircraft engines require high-viscosity oil largely because of the heavy loads on the connecting-rod bearings. The thickness of the oil film that supports a shaft in a bearing is inversely proportional to the load. An increase in load causes an increase in oil pressure in the supporting film and an increased rate of leakage from the high-pressure zone. The reduction in film thickness that results decreases the cross-sectional area of the space through which leakage can occur, thus making possible greater bearing loads. Therefore, the smoother the surfaces, the thinner the film may become before high spots on one surface begin to strike high spots on the other. As soon as metallic contact begins to occur, the friction, and hence the heat generated, increases. Overheating and bearing failure quickly follow.

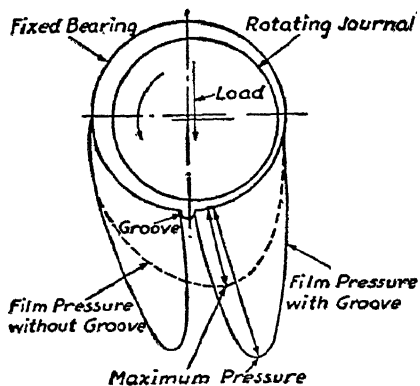

FIG. 128.—Effect of a badly located oil groove on the pressure distribution in a sleeve bearing. (Clower, "Lubricants and Lubrication," New York, 1939.)

Oil Supply Channels.—As can be seen in Fig. 127, oil should be supplied to the bearing in the negative-pressure region on the side opposite to that taking the load. Fortunately, the critical loads on a bearing usually fall on a relatively small part of the circumference, so that the location of the opening through which oil is admitted to the bearing may be on the unloaded side (see Fig. 127). To distribute this oil over the entire length of the bearing, an *oil groove* is often employed. This should be located at the same point as the oil inlet passage and extend axially almost to the ends of the bearing. If it extends all the way to the ends, the oil leakage out through the groove will be serious. The edges of the groove should be rounded to prevent them from having a scraping effect. Although these precautions seem only a matter of common sense, they have not always been observed. Figure 128 shows the effect of an improperly placed oil groove. Note that the maximum pressures occurring in the

proportional to the load. An increase in load causes an increase in oil pressure in the supporting film and an increased rate of leakage from the high-pressure zone. The reduction in film thickness that results decreases the cross-sectional area of the space through which leakage can occur, thus making possible greater bearing loads. Therefore, the smoother the surfaces, the thinner the film may become before high spots on one surface

begin to strike high spots on the other. As soon as metallic contact begins to occur, the friction, and hence the heat generated, increases. Overheating and bearing failure quickly follow.

bearing are nearly twice as great with this groove as without it. This would cut the capacity of the bearing in half.

It is often desirable to supply a bearing with oil from a passage inside the shaft. The oil feed hole out to the journal is located on the antiload side of the shaft if possible. An *oil flat* on the

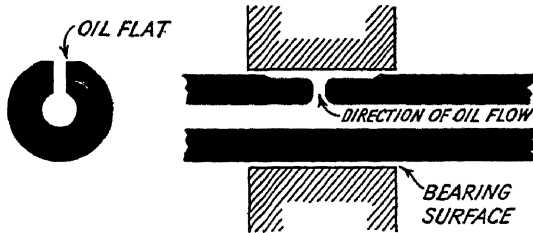

FIG. 129.—Sections through a shaft and bearing, showing an oil flat and oil passages.

journal is generally used to distribute oil over the length of the bearing. As shown in Fig. 129, oil flats are extended to a point just inside the end of the bearing to prevent excessive oil leakage.

A fluid wedge for fluid lubrication may be generated not only between a shaft and bearing but wherever one surface moves with respect to another. Parts such as pistons are designed so that the moving surface will tend to become inclined slightly to the fixed surface and thus build up its own fluid wedge on which it rides freely. It supports its load in much the same way that an aquaplane towed by a motorboat supports the person riding it. Similarly, washers at the ends of small shafts that are subjected to axial loads may be "michelled" as shown in Fig. 130. The pockets cut into the washer serve to break up the surface into elements each of which may build up its own fluid wedge. The pockets also serve to feed oil outward from the supply in the shaft to the bearing surfaces. Oil is thrown off the periphery of the washer after it has been forced from between the bearing surfaces.

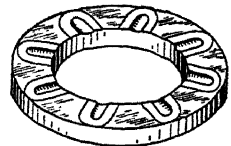

FIG. 130.—Washer "michelled" to provide lubrication for thrust loads.

Boundary Lubrication.—Under conditions of perfect fluid-film lubrication, the viscosity is the only property of the lubricant that affects either the coefficient of friction or the allowable

bearing load. Under conditions of boundary lubrication, the problem is complicated by variations in the affinity of the oil for the surface being lubricated. This property is sometimes referred to as "oiliness." Animal and vegetable oils consist largely of long molecules having a hydroxyl group at one end. That end is strongly attracted to metallic surfaces so that an adherent layer of closely packed molecules tends to accumulate. The structural form of this layer might be compared to that of hair on the back of an animal. Metallic surfaces coated with films of this sort are much less likely to scuff or score, for the adherent film helps to prevent metallic contact. Although straight mineral oils do not form strongly adherent films, a small percentage of animal or vegetable oil, stearic acid, or similar substance may be added to give them this desirable property.

Surface roughness is an important factor under boundary-lubrication conditions. Experience in a number of different fields has indicated that it is not desirable to have two highly finished surfaces contact each other. For example, optically flat glass surfaces (flat within a fraction of a wave length of light) if forced together will be very difficult to separate. When parted, sections will lift out of one surface because they will, in effect, have welded to the other surface. The same phenomenon has been observed with Johansson gauge blocks when the surfaces have been wiped clean. In engines, it has been found that better resistance to scuffing and scoring can be obtained by having at least one of the two surfaces slightly rough if boundary lubrication is important, as in cylinders. Then, if the film of lubricant does break down at some point, the area is localized to that particular high spot. It also appears that the tiny pools of lubricant trapped in the hollows of the rough surface aid in boundary lubrication.

Lubrication of Gears.—Teeth on high-speed gears should not operate in a bath of oil because the liquid caught between approaching teeth must be forced out through the space at the ends. Not only will this churn and unnecessarily heat the oil, but it may cause high pressures to be built up between the teeth of the gears. These pressures will tend to force the gears apart each time a tooth meshes. The loads and vibration that result will considerably shorten the life of the gears by causing pitting of the teeth. A thin film of oil is all that should be provided.

A jet of oil directed into the teeth as they disengage is also excellent, for it will keep them cool. Since most of the oil is thrown off by centrifugal force, only a thin film remains when the teeth engage again.

Lubrication of Ball and Roller Bearings.—It is even less desirable to flood ball or roller bearings with lubricant than it is to flood gears. There is little sliding friction, and so no cooling action is required. Only enough lubricant should be supplied to keep the parts coated with a thin film of oil.

LUBRICATING SYSTEMS

Most modern internal-combustion engines have lubricating-oil systems that supply oil under pressure to all the important bearings and bushings. Many reciprocating parts such as pistons and valve stems are sprayed with oil. The pistons may be sprayed to aid in cooling them.

A gear-type oil pump such as that shown in Fig. 131 is used to deliver oil through a complicated system of passages to the various critical points. The oil pressure on the system can be held constant by an oil-pressure relief valve. In all but the smaller engines the oil must be cooled in an external radiator. This requires a separate pump to scavenge oil from the bottom of the crankcase and pump it through the cooler to a storage tank. The cooled oil may then be drawn from the tank by the supply pump for delivery to the engine oil passages. The term "dry-sump lubricating system" is applied when a scavenge pump and an external supply tank are used and oil is not permitted to collect in the crankcase. This is to distinguish it from a "wet-sump" engine in which the oil is collected and stored in a pool at the bottom of the crankcase. Practically all aircraft engines of more than 150 hp are of the dry-sump type.

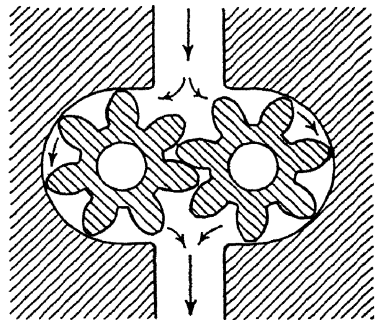

FIG. 131.—Gear-type oil pump.

Strainers placed between the oil supply pump and the engine are intended to remove as much foreign material as possible. Practically, it has been found that it is not feasible to try to

remove particles less than about 5/1,000 in. in diameter. The type of oil strainer most commonly used inside the engine is the Cuno strainer, which consists of a stack of hollow disks a few thousandths of an inch thick, spaced at intervals of 3/1,000 to 7/1,000 in. Strainers of this type are fitted with spacers between the disks, which serve as cleaners when the disks are rotated with respect to the spacers. In some types, the disks may be rotated by hand; in other types, the disks are rotated by a small oil-pressure-driven motor.

Oil System of a V-12 Engine.—Figure 132 is a diagrammatic sketch of the oil pressure system in a Allison V-1710 engine. Oil enters the pressure pump at the lower right of Fig. 132. If the engine is not running, a check valve prevents it from leaking past the pump and gradually flooding the engine. This check valve is designed to open with the small amount of pressure built up by the pump during the first few revolutions of the engine when starting. The oil flows from the pump to an oil strainer, which is provided with a relief valve.

The main oil-pressure relief valve is located in the oil pump so that oil from the pump outlet can be by-passed directly back into the inlet. A balanced-type relief valve is used. The pressure on the filtered oil in the passages just beyond the oil strainer is transmitted back to the relief valve to oppose the force of a spring behind the valve. If the oil pressure becomes too great, the valve is forced back against the spring and oil is by-passed to relieve the pressure.

A number of small passages tap oil from below the strainer to deliver it to bushings, which carry the accessory drive shafts. The largest oil supply passage consists of a pipe that extends forward through the crankcase to supply the main bearings. The crankshaft journals are hollow but are plugged at the ends so that they may fill with oil. Passages connect the hollow journals and crankpins so that oil can be fed from holes through the crankpins to the connecting-rod bearings, as shown in sections *AA* and *BB*. A passage delivers oil forward to the reduction gears and the propeller governor, while other passages carry oil up through the tower shafts to the camshafts and valve mechanism. The accessory drive shaft along the top of the crankcase is supplied with oil by a passage from the center main bearing. It is hollow and delivers oil to the supercharger-impeller drive

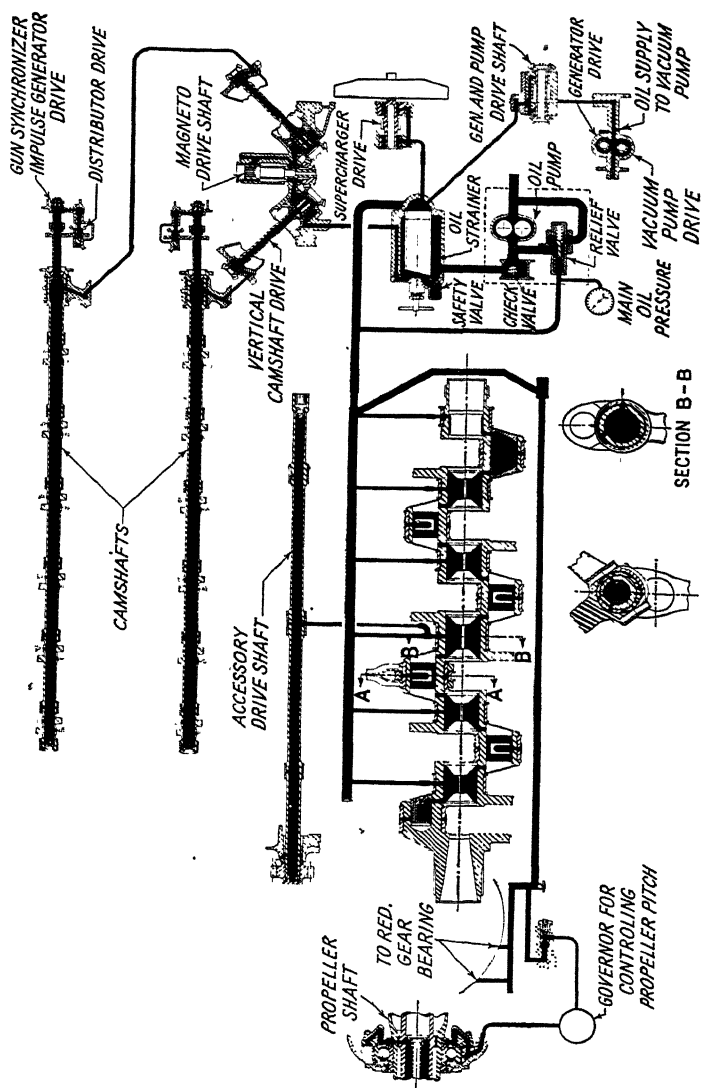

Fig. 132.—Schematic diagram of Allison V-1710-C15 lubrication system. (Allison Division, General Motors Corp.)

system. The pistons and cylinder walls are lubricated by oil which sprays from the ends of the connecting-rod bearings.

After lubricating the bearing surfaces, the oil drains to the bottom of the crankcase. The oil pan is scavenged in level flight by the main scavenge pump at the rear. In a dive the load is thrown on a double scavenge pump in the nose. One portion scavenges the main crankcase, while the other portion with its inlet near the thrust bearing scavenges the nose section. The discharge from these pumps is connected to a single oil outlet connection at the rear of the engine.

Oil System of a Radial Engine.—Although various makes and models of radial engine differ, especially in the arrangement of the passages in the immediate vicinity of the oil pump, most engines use a system similar to that described above for the Allison V-1710. Figure 133 shows a section through a Wright C14B engine. Oil flows from the pump to the relief valve and from there to the strainer. Unlike the Allison, the pressure controlling the relief valve is that ahead instead of beyond the strainer. Oil from the relief valve is by-passed to the inlet side of the pump.

From the strainer, oil is carried to the rear end of the crankshaft extension or the tail shaft. There it collects in an annulus, from which most of it flows through holes in the journal into the interior of the shaft, although some of it is tapped off from the annulus through passages to lubricate the accessory drive shafts in the rear section. If a supercharger two-speed clutch is used, it is hydraulically operated and also receives oil under pressure through passages in the rear section. From the inside of the tail, shaft, oil flows through drilled passages out into the crankpin. Since the centrifugal force acting on the master-rod assembly is so large that it greatly exceeds the combustion forces, the master rod rides on the inside of the crankpin at all times. Because of this, the oil is fed to the master-rod bearing through a hole in the outer part of the crankpin. A small tube spun into this feed hole makes the hollow space in the crankpin serve as a centrifuge to remove small particles of foreign material from the oil. This small piece of tubing extends inward to about the center of the crankpin. The foreign material in the oil tends to be thrown radially outward, and only clean oil flows up and into the tube to be fed out to the master-rod bearing. An "end

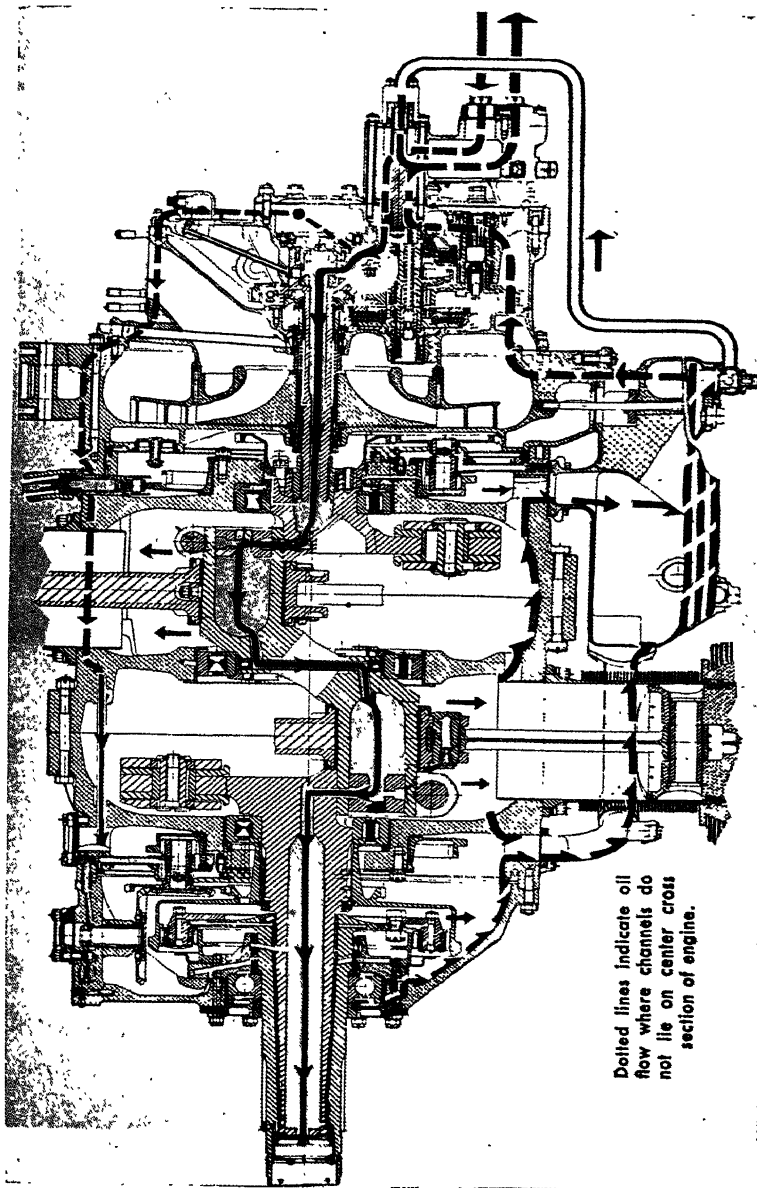

Dotted lines indicate oil flow where channels do not lie on center cross section of engine.

Fig. 133.—Lubrication system of Wright C14B twin-row radial engine. (Wright Aeronautical Corp.)

seal" at the ends of the master-rod bearing limits the leakage there and thus controls the oil flow through the bearing so that it will not vary greatly with bearing clearance. The knuckle-pin bushings are lubricated by small passages drilled from the end seal through the knuckle-pin lock plate, which holds it in place. Holes in the knuckle-pin lock screws feed oil into the knuckle pins, from which it flows to the bushings. The pistons and cylinder walls are lubricated by oil thrown off from the master-rod bearing as well as by jets in the crankcheeks that spray oil outward.

Drilled oil passages carry oil forward to the front extension of the crankshaft. Some oil flows outward through oil seal rings to lubricate both the cam bearing and the trunnion on which ride the cam intermediate drive gear and pinion. The rest of the oil flows farther forward to pass out from the crankshaft and propeller shaft through another set of oil seal rings to the nose section. Oil is also supplied to the nose section through a pipe leading directly to the propeller governor. Drilled passages in the housing are connected to the propeller governor and to the tappets. Holes in the tappets match with holes in the tappet guides so that oil flows into each tappet when it has opened its valve. Oil can then flow up through the hollow tappet and push rod into the rocker arm. It flows through the rocker arm to lubricate the rocker bearing, from which it is thrown out onto the valve stem and the valve springs. Oil may drain from the rocker boxes back into the crankcase through the push-rod housings.

Oil from all points in the engine drains into the sump located beneath the main crankcase. A scavenge pump having approximately twice the capacity of the supply pump draws oil from the sump and returns it to the supply tank. The high capacity of this pump makes it possible to keep the sump practically empty.

Individual engines make use of various elaborations of the system described above. Practically the entire engine, including the reduction gears, valve gear, and cam and cam drive gears, may be lubricated from the crankshaft as in most Wright engines, or steel tubing may be used to give an independent supply of oil to the nose section as in Pratt and Whitney engines.

Breathing.—A certain amount of gas always leaks from the combustion chamber past the piston rings into the crankcase.

A vent called a *breather* must be provided to carry this gas off as well as to equalize the pressure between the crankcase and the atmosphere under conditions of changing temperature or altitude. If the pressure in the crankcase were to become greater than atmospheric, oil leakage through all the joints at the surfaces between the housings and cylinders, as well as through the seals around the propeller and accessory drive shafts would present a serious problem.

It is difficult to arrange a vent system so that no oil can escape through the breather opening. Some engines have been designed to breathe through an opening in the center of the front crankcheek. The front part of the crankshaft can be made hollow so that vapor entering this opening is vented off through the propeller shaft. The centrifuging action of the crankcheeks, counterweights, and rods causes the vapor fed to the breather to be substantially free of oil. Other engines have one or more vents, usually at the top or at the rear, which can be connected to the oil tank so that any oil which enters the vent line may be caught in the oil tank. The latter is vented to atmosphere.

OIL FLOW AND HEAT REJECTION

Effect of Pressure and R.P.M. on Oil Flow.—From the standpoint of oil flow, the engine may be considered as a system of orifices and capillary tubes. Thus an increase in the oil pressure on the system will cause an increase in oil flow. The effects of rpm are somewhat more complex. The gear-type pump has an essentially constant displacement. At low rpm, it cannot deliver oil to the engine at a rate high enough to maintain the normal oil pressure.

When a fairly high idling speed is reached, the capacity of the pump to deliver oil becomes greater than that of the engine to flow oil and the excess is by-passed through the relief valve.

The capacity of the engine to flow oil will increase somewhat with rpm owing partly to the greater amount forced out by centrifugal force and partly to higher bearing temperatures, which lower the viscosity. If the oil pressure and inlet temperature are kept constant, the oil flow at take-off speed will run about 50 per cent greater than that at a low cruising speed. Variation in engine power output at constant rpm has little effect on oil flow.

Effect of Oil Inlet Temperature on Oil Flow.—The viscosity of an oil falls off rapidly with an increase in temperature, as shown in Fig. 123. The oil flow is approximately inversely proportional to the viscosity; hence, the engine oil flow increases with oil inlet temperature. Figure 134 shows both the oil flow through the engine bearings and the total flow through the pump plotted against oil inlet temperature. The oil pressure would be held constant by the relief valve up to the point where the pump-delivery curve intersects that for the flow through the engine.

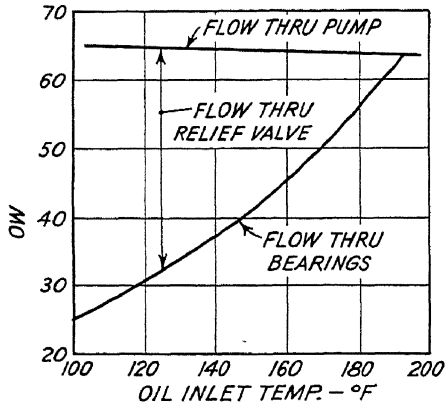

FIG. 134.—Effect of oil inlet temperature on oil flow. (*Caminez, Jour. I.A.S., vol. 1, No. 3, July, 1934.*)

Higher oil inlet temperatures would be accompanied by a drop in oil pressure and no increase in flow. Note that the flow through the pump falls off gradually with the higher oil temperature. This is caused by increased leakage back through the gears in the pump due to lower oil viscosity.

Oil Temperature Rise.—A rise in oil temperature occurs as the oil passes through the engine. It is caused by heat transmitted to the oil from the hot cylinder walls and pistons and by heat added to the oil by friction in the bearing surfaces. One of the most important single sources of heat, for example, is the master-rod bearing. Since all the frictional loss goes into heat carried off by the oil, the heat added to the oil in a typical master-rod bearing operating at take-off speed would be given by the product of the coefficient of friction, the total load on the bearing, and the rubbing velocity of the bearing surface. For a large engine the coefficient of friction would run about 0.002, the bearing load

about 45,000 lb, and the rubbing velocity 2200 ft per min. The power loss is 199,000 ft-lb per min, or 255 Btu per min. If the oil flow to that bearing were 20 lb per min and a mean specific heat of 0.5 were assumed for the oil, a temperature rise of 25.5°F would result. A sufficiently high rate of oil flow to a bearing must be provided to carry off the heat generated in that bearing under the most severe conditions. Similarly, heat caused by friction in the reduction gears, the pistons and cylinders, and other parts of the engine must be carried off by the oil.

The frictional losses increase approximately as the 1.5 power of the rpm. On the other hand, they decrease with oil viscosity, *i.e.*, with increase in oil inlet temperature. It is interesting to note that, if a heavy summer oil is used, the power output of the small horizontally opposed engines may be increased as much as 5 per cent or more by operation with high oil temperatures. Even better performance can be obtained for short intervals if a light oil is used. However, the light oil may not be viscous enough to carry the bearing loads if the engine is allowed to heat up.

The amount of heat added to the oil from the combustion chamber depends on the temperature difference between the associated parts and the oil. This, in turn, depends on both the oil inlet temperature and the coolant-jacket temperature in liquid-cooled engines or the cylinder-base temperature in air-cooled engines. Another factor to be considered is the cooling effect of the air stream passing over the crankcase. This may cool the oil and reduce the oil outlet temperature considerably.

Heat Rejection to the Oil.—The importance of the lubricating oil as a coolant may be indicated by the fact that the heat which it must carry from the engine often amounts to more than 10 per cent of the heat removed by the coolant. If the maximum oil inlet temperature is fixed, the total heat rejection to the oil under the most severe conditions determines the size of the radiator needed to keep the oil cool. The heat rejection to the oil is simply the product of the oil flow, the oil temperature rise, and the specific heat of the oil. As shown in Fig. 123, the specific heat depends somewhat upon temperature, but is often taken as 0.5 for convenience.

Figure 135 shows the variation in heat rejection to the oil for a liquid-cooled engine operating along a propeller-load curve.

Two curves are given to indicate the pronounced cooling effect of the air blast from a propeller when the engine was operated without a cowling on a fixed test stand. Figure 136 shows the

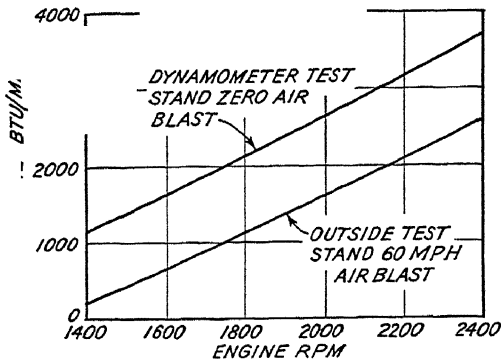

FIG. 135.—Heat rejection to the lubricating oil as a function of rpm on a propeller-load curve. (Caminez, *Jour. I.A.S.*, vol. 1, No. 3, July, 1934.)

effect of engine power output at constant speed on the heat rejection.

The heat rejection to the oil is very greatly dependent on the inlet temperature. Figure 137 shows the heat rejection to the oil at a constant speed and power plotted against oil inlet tem-

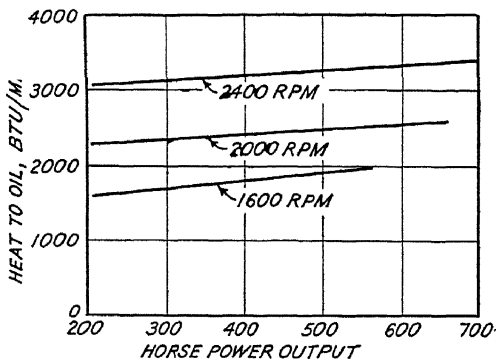

FIG. 136.—Effect of power output on heat rejection to the oil at constant rpm. (Caminez, *Jour. I.A.S.*, vol. 1, No. 3, July, 1934.)

perature. Note how rapidly the heat rejection falls off at an oil inlet temperature greater than 150°F. As in the case of the coolant of a liquid-cooled engine, increasing the allowable operating temperature greatly decreases the radiator size. This is due both to the decrease in total heat rejection and to the

increased temperature differential between the oil and the cooling air. The higher temperature differential alone will permit the radiator size to be cut approximately in half if the maximum allowable oil inlet temperature is raised from about 150°F to about 200°F on the basis of the usual design value of 100°F for the cooling air temperature. As can be seen from Fig. 137, the decrease in the heat rejection to the oil as a result of the higher inlet temperature would allow the radiator size to be again halved. The combined effect of these two factors would make the radiator required for a 200°F maximum oil inlet temperature only

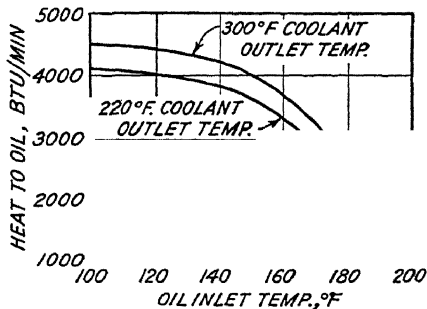

FIG. 137.—Effect of oil inlet temperature on heat rejection to the oil at a constant power and rpm. (*Caminez, Jour. I.A.S., vol. 1, No. 3, July, 1934.*)

about one-fourth the size of that needed if the inlet temperature could not exceed 150°F. Of course, the higher oil inlet temperature would cause a much more rapid rate of oil deterioration, but this might well be justified by the savings in weight and radiator drag which would become possible.

Scavenging Difficulties.—A factor that should be noted in connection with high oil inlet temperatures is connected with the problem of scavenging. If the oil cooler is not adequate to maintain the correct oil inlet temperature, the latter may rise to more than 200°F. The rapid increase in oil flow with oil temperature then brings on a dangerous condition, especially at high rpm. The oil may be pumped into the engine more rapidly than it can be scavenged out. This is particularly likely in radial engines in which the oil must flow through relatively long passages from the sump to the scavenge pump. If the pressure drop through these passages becomes fairly high, the suction will be broken and the pump will “air-lock.” The condition is made worse because the higher oil flows cause an increase in the amount

of oil being churned in the narrow confines of the crankcase. This causes the amount of air suspended in the oil in the form of bubbles to increase, and thus there is an increase in the volume that must pass through the passages to the scavenge pump. The net effect is such that, if the oil inlet temperature is gradually increased, a critical point will be reached at which scavenging will suddenly stop almost entirely and the engine will rapidly *load up* with oil. When this occurs, the oil supply tank may be emptied in a fraction of a minute. If the engine is not immediately stopped, the resulting interruption in the oil supply will cause the master rod-bearing to seize.

Even before the oil inlet temperature becomes high enough to bring about an interruption in scavenging, the amount of oil being churned in the crankcase may increase seriously. This will cause a pronounced increase in the frictional losses there and may cause oil to be thrown out the breather.

The drop in atmospheric pressure during a climb to high altitudes may cause difficulty. A suction on the order of 10 in. Hg at the inlet to the scavenge pump is found in many engines. If such an engine is taken upward in a climb, one could scarcely hope to reach an altitude higher than that at which the atmospheric pressure would be about 12 in. Hg, *i.e.*, an altitude of about 23,000 ft. At higher altitudes, and possibly at lower altitudes, scavenging would be poor or might even stop completely. Even before the latter occurred, the engine would load up with oil, and oil would be discharged through the breather. Many of the later model engines employ scavenge pumps placed in or next to the sump to eliminate this difficulty.

References

1. CLOWER, J. I.: "Lubricants and Lubrication," 1st ed., McGraw-Hill Book Company, Inc., New York, 1939.
2. CAMINEZ, H.: The Oil Cooling Problem in Aircraft Engines, *Jour. I.A.S.*, vol. 1, No. 3, July, 1934.

CHAPTER XIII

AIRCRAFT-ENGINE OVERHAUL AND PART DURABILITY

Most people take for granted the fact that the finest aircraft engines must be overhauled at rather frequent intervals while far less expensive automobile engines run three or four times as long without attention. This is largely due to the fact that aircraft engines operate at nearly twice the bmep of most of the other present-day internal-combustion engines and so must withstand much higher pressures and temperatures in the combustion chamber. The pistons, rings, and valves in particular are subjected to severe abuse. Light weight and compactness, however, are essential; every part in the engine must be made just as light as possible. The crankshaft of an aircraft engine, therefore, may be only twice the size of that of an automobile engine and yet may be required to carry ten times the horsepower. Each part is thus made only a little stronger than it has to be for the worst loads it is likely to carry. Unusual conditions to which an occasional engine may be subjected, such as overspeeding in a dive, may overload one or more parts and cause failure. Fortunately, such occurrences are rare. However, a certain amount of regular part replacement must be made as a result of wear, fatigue cracking, corrosion, and similar factors. The usual practice with an automobile engine is to drive it until trouble occurs; then, if necessary, the driver can get out and walk. Since this would be a disastrous policy in aircraft, it has been the practice to overhaul aircraft engines completely at regular intervals to clean and service all parts and to make certain that they are in first-class condition. Just as automobile engines must have the carbon scraped from the cylinder head, the valves reground, and new piston rings installed, so aircraft engines must be overhauled to have similar maintenance work done on them.

The problems involved in the overhaul of aircraft engines may be classified in four groups, *viz.*, the servicing or replacement of

parts because of surface deterioration chargeable to factors such as wear, the replacement of parts because of cracks or fractures, the removal of engine deposits accumulated during service, and the inspection of parts to determine the servicing and part replacement necessary.

SURFACE DETERIORATION

Wear.—Wear is an obvious cause of part replacement. There are many moving surfaces in an engine all of which are subject to some wear, especially if highly loaded. One of the clearest instances is that of wear between a shaft and a bushing. Wear would cause some increase in the oil flow through a bushing and would allow the shaft some increase in freedom of movement. If a gear were on the shaft, an increase in gear-tooth backlash would result. Vibration might also cause trouble due to the increased degree of freedom of the shaft. The familiar “pounding” of a rod or crankshaft main bearing in an automobile is an example of the difficulty that increased bearing clearances may cause.

Such bearing and journal wear may not be uniform. Crankpins, for example, tend to become “out of round.” The same is true of any case in which the principal loads always act on the same portion of the bearing surface. Bearings and bushings are generally made of relatively soft material and the shaft of hardened steel so that the greater part of the wear will occur in the bushing. Shaft wear is usually on the order of 0.001 in., while bushing wear may be 0.002 or 0.003 in. The usual practice is to replace worn bushings or bearings and, if necessary, grind or lap the shaft journal until it is again circular. If the wear is too great, the journals may be plated with chromium and ground down to the correct size. Such regrinding or plating of the crankshaft journals may require rebalancing of the shaft.

Wear, Scuffing, and Feathering of Piston Rings.—The boundary-lubrication conditions existing between the cylinder walls, pistons, and rings cause these parts to wear more rapidly than other parts of the engine. Since the piston rings are the most easily replaced, they are made of relatively soft graphitic cast iron so that most of the wear occurs on them. The graphite in the iron is also effective as a lubricant, even at high temperatures. In piston rings made with a tapered face (see Fig. 16) the portion

polished, or brightened, by wear should appear as a narrow, even circumferential line if little wear has occurred. A certain amount of wear should occur to ensure a gastight contact between the cylinder wall and piston ring. This is the reason for running-in piston rings: until they have been *seated* against the cylinder barrel, excessive passage of oil from the crankcase to the combustion chamber will occur. Wear may increase the width of this bright area from a fine line to a band half the width of the ring. In some cases, notably the top rings, the entire face of the ring



FIG. 138.—Scored piston.

may be worn and polished. If the wear is uneven, it will be indicated by an unevenness in the bright band around the ring.

In addition to the very slow wear caused by a polishing action, used rings may show little vertical streaks or fine scratches where the surface has been *scuffed*. In cases of serious scuffing, a metallic burr may be found along the edge of the ring. This is similar to the "featheredge" occurring on an improperly sharpened knife. A ring with such a burr is said to be *feathered*. The face of piston rings is sometimes plated with tin or chromium to reduce the tendency to wear.

Cylinder and Piston Scoring.—Cylinder-wall lubrication may break down to the extent that the piston rings will scuff or feather without the occurrence of more serious damage; however, if lubrication breaks down any further, *scoring* of the piston and

cylinder wall may occur. The result is scratches in the piston and cylinder wall (see Fig. 138). If slight, these may appear only in the piston or cylinder and may be stoned out. If both cylinder wall and piston are scored appreciably, both may have to be discarded. This is due to the fact that minute cracks may be left in the surface, which will cause a fatigue failure in the barrel.

Metal chips from a scored cylinder or piston, dirt, or other foreign material may enter the clearance between a bearing and shaft and scratch the surfaces. If this occurs, the bearing surfaces are said to be *scratched* or *scored*.

Seizing.—Failure of lubrication between a shaft and a bushing may result in *seizing*. The heat generated by the friction in a bearing is normally carried away by the oil. Interruption of the oil supply will stop this flow of coolant. Heat will be generated rapidly to raise the temperature at the surface of the bearing above its melting point. A form of welding will occur when the molten bearing surface comes in contact with the journal and adhesion between the two surfaces suddenly takes place. This may cause the bushing to turn in its support (the housing, etc.). If it is restrained from turning, the soft bearing material may shear internally and break up into many flakes. Seizing may be caused by too small a supply of oil, insufficient clearance between the moving parts, or overloading of the bearing such as would occur if the engine were overspeeded. Seizing may also be of a secondary nature—a number of factors might be present that would overload the bearing or reduce its oil supply.

Galling, Chafing, Corrosion, and Pick-up.—Wherever two parts are in contact, presumably with no relative movement between them, some form of surface deterioration is likely to occur. This is a result of the tendency toward slight relative motion of the parts with respect to each other, which, in turn, is caused by the strains inevitably accompanying stresses. Where the two halves of a crankcase contact each other, for example, a certain amount of relative movement occurs. It is insufficient to generate a fluid wedge, and so rudimentary boundary-lubrication conditions prevail. One surface tends to adhere to the other, with the result that both tend to be torn and scarred. Classification of the different types of this sort of surface deterioration occurring in aircraft engines is difficult and must of

necessity be somewhat arbitrary. In general, *galling* occurs when two surfaces under very heavy unit contact pressures, *i.e.*, pressures of 30,000 psi or more, tend to move with respect to each other as a result of vibration or the intermittent application of load. *Chafing*, or *fretting*, occurs between two less heavily loaded surfaces, the amplitude of the motion usually being considerably greater than in the case of galling. The bore of the piece of master rod in Fig. 140 was chafed by the bearing shell. Some unaffected areas are bright, while other areas are rough and chafed. *Pickup* is the term applied to the adherence of small portions of the surface of a metal such as that of a bronze washer to a mating part such as a steel gear. It may also accompany galling or chafing.

Corrosion.—A peculiar form of corrosion may accompany either galling or chafing of steel parts if any moisture or water vapor is present. It is characterized by a reddish deposit of fine iron oxide, which is quite noticeable when the engine is disassembled. This is called *fretting corrosion*. Some authorities feel that all chafing is due to this type of corrosion.

Ordinary rusting of steel parts often occurs when engines are allowed to stand idle for days at a time. The severity of this sort of corrosion depends on atmospheric conditions. In spots close to salt water it is likely to be especially troublesome and may be accompanied by corrosion of exposed aluminum, magnesium, and cadmium surfaces. All the cadmium plating may often be corroded from new steel nuts in the space of a few months even though the storage space may appear to be clean and dry. Cast-aluminum and -magnesium parts, particularly the latter, are rapidly attacked by sea water or salt spray if left unprotected by paint or special processing.

Another source of trouble is water which tends to condense out at night on cold metal parts or which may condense from the vapor in the crankcase after the engine is stopped. The oil seal rings around the propeller shaft are particularly susceptible to rusting of this sort.

Corrosion of the cylinder head, piston, valves, and cylinder barrel due to lead products in the fuel is relatively common and is referred to as *lead corrosion*. The high temperature of the top of the exhaust-valve head makes it particularly susceptible to corrosion from this source. Figure 17 shows the temperatures

at which the various parts of an exhaust valve normally operate, while Fig. 139 shows the type of corrosion that may occur. Note that the only area seriously affected in Fig. 139 is the deeply pocked band out toward the edge. From Fig. 17, it can be seen that this region is not in direct contact with the coolant. A ridge of the uncorroded stellite face has been left exposed



FIG. 139.—Burned exhaust-valve head.

and can be clearly seen in the lower right quarter of the view. Corrosion of the cylinder barrel, the cylinder head, and the piston occurs only while the engine is stopped and can be prevented by slushing with oily compounds prepared especially for that purpose.

PART FAILURES

Failures of engine, landing gear, and other aircraft parts present one of the most interesting groups of problems in the aircraft field. In a surprisingly large proportion of cases the exact cause of the failure can be determined. This makes it possible to take immediate steps to prevent a recurrence of the trouble. Even in severe crashes, it is usually possible to state

definitely whether broken parts were the cause or the result of the crash. In this way the engine may often be absolved of unjust accusations. Fortunately, crashes resulting from broken parts are rare. Most difficulties involving part failures are found during routine inspections, when their sources are much easier to determine. Each case should be examined by an expert, though all engineers should be familiar with the problem and, if at all possible, should gain some firsthand experience by carefully inspecting whatever specimens they have an opportunity to see.

Fatigue Cracks.—Parts are carefully inspected during each overhaul to make certain that no cracks have begun to form. These are usually the result of fatigue. Once started, they progress rapidly. Their source is always some stress concentration such as that which occurs at the root of threads, in the fillets at abrupt changes in section, at small irregularities in otherwise smooth surfaces, or at inclusions or imperfections in faulty material. Tool marks, scratches, chafe marks, and any other breaks in a surface, particularly if they occur in a fillet, are typical of the irregularities causing fatigue cracks.

Fatigue cracks are characterized by a nucleus, which is a small, well-defined area in the fractured face at the source of the crack. In steel parts circular markings often surround and striations radiate from the source, or nucleus, and clearly indicate it. The nucleus is also indicated by the "grain" in the fracture, which appears fine and polished near the nucleus and becomes progressively more coarse at points farther removed until the line of final tensile fracture is reached, where reduction of the area of the material is evident.

Any cracked parts should be examined and the cause of the crack determined. If this cannot be done at the overhaul shop, the parts should be tagged with all pertinent information and sent to a laboratory for examination. If an appreciable number of the same type of failure occur, a change in overhaul procedure or a change in design of the part is clearly needed.

Difficulty may occasionally be experienced with actual rupture of a part during operation. Fatigue cracks may not be caught at an inspection or may progress to the point of failure of the part between overhauls. The most common cause of part failure during operation is misuse of the engine.

Nicks or slight bends in connecting rods may cause failure of the latter, with disastrous results for the interior of the engine. Severe vibration due to propeller unbalance, for example, may cause cracks to form in the aluminum housings, *i.e.*, the crankcase, mounting section, etc. In-line engines have sometimes been afflicted with torsional-vibration trouble which has caused crankshaft failures.

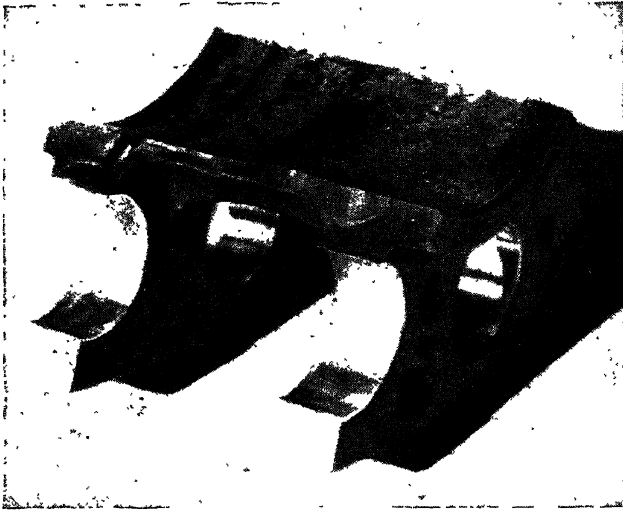

FIG. 140.—Part of a failed master rod showing a fatigue “oystershell” in the upper right portion of the fractured surface.

The cylinder heads of an air-cooled engine will operate for thousands of hours at high power if no detonation is present. If severe detonation occurs at high power, however, the cylinder head may be split by the hammering concussions in a matter of hours, or even minutes in extreme cases. Cracks in cylinder heads, like fatigue failures in steel, begin at some point of stress concentration such as a spark-plug insert.

Figure 140 shows a fatigue failure in a master rod. The nucleus is located about one-quarter of the way in from the left along the top edge of the fractured face. Note both the concentric markings and the radial striations around the nucleus, often called a fatigue “oystershell,” and the finer grain in that region. This rod failed because of chafe marks in the master-rod bore caused by chafing between the rod and the steel bearing shell (see Fig. 138). The nucleus was found to be located in the

bottom of one of these chafe marks. The stress concentration there caused the fatigue crack to begin. After the failure had progressed out of the knuckle-pin holes for No. 6 link rod, the greatly weakened rod probably pinched the master-rod bearing and caused a bearing failure.

Pitting.—A less spectacular but more common type of fatigue failure than that caused by cracks is called *pitting*, which occurs in ball and roller bearings and in gear teeth. It is caused by

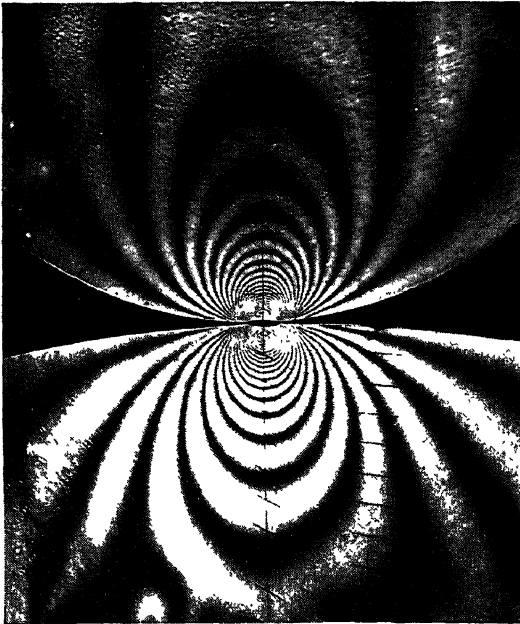

FIG. 141.—Photoelastic study of the stresses set up at the point of contact between a roller and the inner race of a roller bearing. (*Buckwalter, S.A.E. Trans., vol. 36, 1941.*)

high contact loads concentrated on small areas. The stress distribution that occurs under such conditions can best be seen in models stressed and examined in a polariscope under polarized light. When this is done, a series of dark bands, or interference fringes, is formed, which indicates the stress distribution. Figure 141 shows the appearance of these fringes in two cylinders that have been forced together under a considerable load. Although an exact analysis is somewhat complicated, the stress intensity at any point in the model shown is indicated by the

number of fringes between that point and the nearest free edge. A study of the model will show that this maximum stress occurs not at the point of contact but a short distance inside the surface, *i.e.*, at the small "eyes" in the fringe pattern for each cylinder near the point of contact. From this, one would expect to find fatigue failures that had started beneath the surface in gear teeth, for example. This is precisely what happens. A fatigue crack forms and spreads below and parallel to the surface until a piece flakes out to leave a pit. Pitting of gear teeth and of

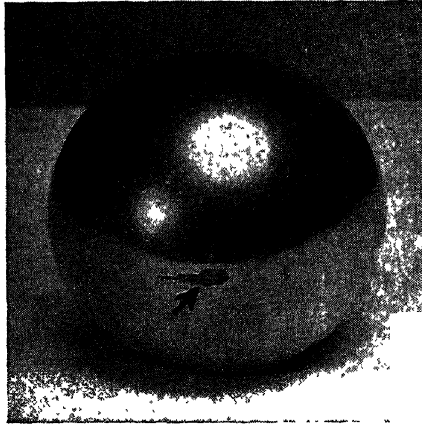

FIG. 142.—Pitted ball from a ball bearing. (*Motor Boating.*)

ball and roller bearings is relatively common. Pitted parts must be discarded because large fatigue cracks may start in the stress concentrations at the base of the pits and cause a failure of the whole part. Figure 142 shows a pitted ball from a ball bearing.

Before actual pitting occurs, the surface of a gear tooth begins to assume a "worked" appearance much as if it had been peened. The races of ball and roller bearings appear *brinelled*. That is, depressions appear in the race surfaces as though the balls or rollers had been subjected to sufficient force to cause permanent indentations.

Failures Due to Faulty Material.—The material of which a part is made may be of poor quality and thus cause a failure. Figure 143, for example, shows a fracture through a cast-aluminum housing. Porous material was responsible in this case. Sand inclusions, "cold shuts," and oxide inclusions, voids, shrinkage cracks, and blowholes are other faults that are likely

to cause failures. Close foundry control and rigid inspection procedures have reduced troubles from these sources to an amazingly low figure. Slag and oxide inclusions in forged parts also cause difficulty occasionally.

Fortunately, failures such as those described are rare, but they are rare only because of the rigid inspection policies of the engine

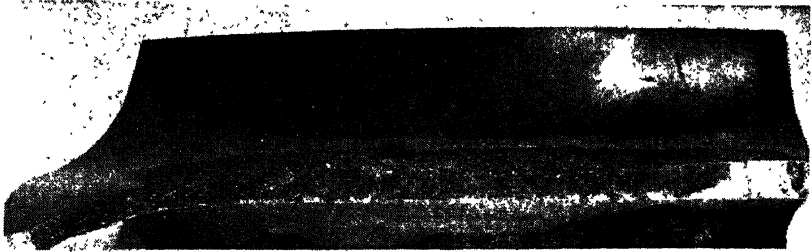

FIG. 143.—Fractured aluminum casting showing porous structure. (*Motor Boating.*)

manufacturers, the operators, and the overhaul shops. Each part must be carefully inspected at every overhaul, and any defective parts must be replaced.

ENGINE DEPOSITS

Combustion-chamber Deposits.—A crust of hard carbon mixed with lead compounds from the fuel tends to form on the top of the piston and on the inner surface of the cylinder head in unsupercharged engines. The operating temperatures in highly supercharged engines, however, are sufficient to burn out most of the hard carbon that might form. As a result, deposits accumulated in the latter engines are much thinner and consist principally of lead compounds. In either case the material should be scraped off during overhaul, for it increases the likelihood of detonation.

Piston-ring Groove Deposits.—Probably the most troublesome type of engine deposits are those left in the piston-ring grooves. Resinous compounds formed from both the oil and the fuel may collect and cause the piston rings to stick in their grooves. Sometimes rings will stick only when the engine is hot, appearing quite free when cold. In other cases, depending on the kind of deposit, the rings may be stuck when cold but quite free when

hot. When rings stick in their grooves, the engine loses compression and power. The oil consumption will also increase markedly. Since the upper rings operate at the highest temperature, they are the ones most likely to become stuck. Deposits in the ring grooves must be removed during overhaul. Care must be exercised to avoid removing metal, thus increasing the width of the grooves and causing excessive ring side clearances. The latter should be checked with a feeler gauge when the new rings are installed.

Valve-stem and Valve-guide Deposits.—Deposits on the valve stem and in the valve guide may cause the valves to *stick*. Exhaust valves are particularly susceptible to trouble of this sort because they operate at a higher temperature than any other part of the engine. Such deposits are hard and abrasive, for they consist largely of lead compounds and dust from the air. These deposits also cause wear in the valve guide. When a large amount of wear occurs in the outer end of the guide, it is called "bellmouthing."

Since intake valves operate at much lower temperatures, deposits on their stems are much less of a problem. However, oil that passes down between the stem and the guide deposits on the underside of the head to leave a flaky but adherent coke-like deposit that must be cleaned off.

Varnish.—Resinous material, coming principally from the oil, deposits on the underside of the pistons and on the rods, crankshaft, crankcase, valve stems, valve springs, etc., to form a hard thin adherent film that looks much like a dark-brown or black lacquer. Such a film has the advantage that it protects the surfaces from corrosion. It is inclined to chip off if it becomes thick, in which case the chips formed tend to clog the oil strainers. Sometimes hard particles get into the bearings, leaving marks or scratches. Although thin films are not objectionable, heavier layers should be cleaned off. If the parts are to be magnafluxed, the parts must, of course, be thoroughly cleaned.

Varnish accumulations on aluminum parts such as pistons and crankcases may be removed by immersing the parts in various special solvents and solutions. Care must be exercised to prevent corrosion of the metal. Electrolytic cleaning in special baths has been found to have many advantages for cleaning steel parts.

Sludge.—Tarry, pasty, or crusty deposits often collect in recesses or pockets. Such deposits may be so heavy in the separators of ball or roller bearings that they restrict the movement of the balls or rollers. Sludge collects in hollow crankpins, especially those designed for that purpose. Lead compounds from the fuel form a large part of such deposits. Similarly, other rapidly rotating parts in the engine tend to centrifuge sludge from the oil passing through them. Supercharger clutch mechanisms designed to rotate with the lay shaft of the impeller gear system have given much trouble with sludging. Sludge may deposit out at any other point in the engine, particularly if the temperature there is especially high.

Prevention of Deposits.—Probably the most important factors affecting engine deposits are the oil used, operating temperatures, and time. As a rule it is possible to obtain an oil that will not cause the accumulation of objectionable amounts of varnish and sludge between overhauls. Changing the oil after specified periods will also help.

INSPECTION

Magnaflux.—A number of aids to the careful inspection of parts are commonly used. One of the most important is the magnaflux apparatus by which steel parts are strongly magnetized and dipped in a mixture of fine magnetic particles and kerosene. A crack or other discontinuity in or near the surface of a part causes a local disturbance in the magnetic field, which in turn causes the magnetic iron oxide powder to cluster around the irregularity, making it conspicuous. A skilled operator will immediately notice any such cluster of powder and can usually tell the nature of the defect. After inspection in the magnetized condition, the part can be demagnetized completely and returned to service. Connecting rods, propeller and crankshafts, gears, and other steel parts are regularly magnafluxed. Figure 144 shows cracks at stress concentrations in a splined part as revealed by magnaflux powder. These were caused by overloading. Figure 145 shows grinding cracks in the fillet between a crankpin and crankcheek. These were caused by local overheating in the grinding operation during manufacture.

A common magnifying glass is a valuable aid for the examination of surface markings. Such a glass usually makes it possible

to differentiate between a superficial scratch and a crack, a pit and an indentation.

Etching.—The inspection of aluminum parts may be facilitated by the use of etching solutions, which will attack the metal in the vicinity of a crack more readily than the rest of the material, thus making it clearly visible to the naked eye. Aluminum can be

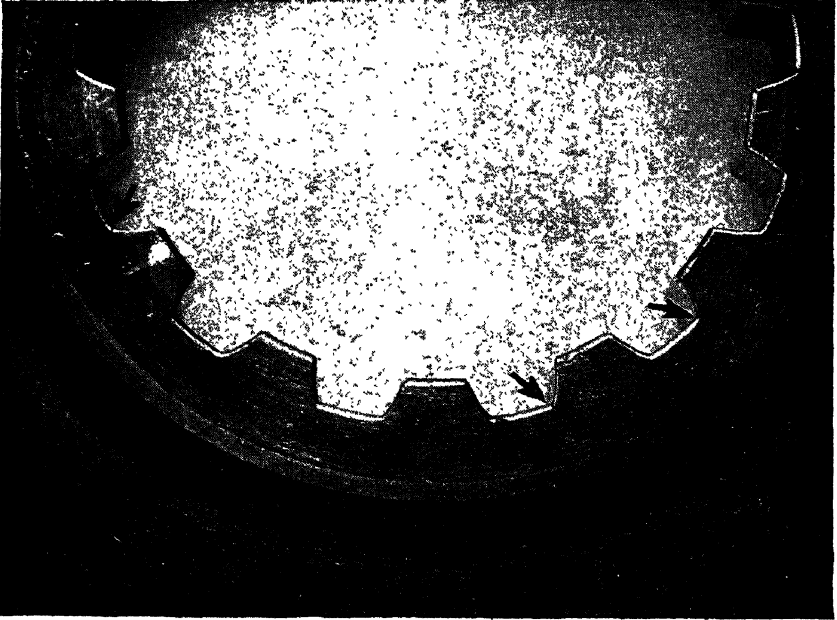

FIG. 144.—Cracks at the roots of splines in a gear hub are shown clearly by magnaflux-powder accumulation. (*Motor Boating.*)

etched in a dilute solution of sodium hydroxide or a number of dilute acids such as hydrochloric and fluoric acids.

The subject part is first etched in one of the above, then washed in water, and then the residual oxide film on the surface is neutralized by washing the part in nitric acid and again in water. This nitric acid treatment leaves the aluminum clean and bright for inspection.

Wear Measurements.—The micrometer is an essential tool in any inspection for wear. Both internal and external micrometers in sizes ranging from $\frac{3}{4}$ in. for valve-guide wear to 6 in. for cylinder-barrel wear must be used. Journals and bushings must be measured to check clearances, while other parts such as ball

bearings and knuckle pins that must be installed with a tight fit in or on another part may require checking for size and fit. To supplement the micrometer for measuring distortion or wear, "ring"- and "plug"-type gauges may be used. Gauges are also used for checking tapped holes such as those in steel crankcases.

Part Retirement.—In addition to those parts which are replaced because they have been found to be defective, many parts are replaced at regular intervals to ensure trouble-free operation.



FIG. 145.—Grinding cracks in the fillet between a crankpin and crankcheek.
(*Motor Boating.*)

Piston rings and gaskets are replaced at every overhaul. After years of experience, it has been found that other parts have fairly well-defined lives. At the end of a certain number of hours of service, they are likely to give trouble. This uniformity is due to the fact that aircraft parts are made to have the highest strength possible. They are inspected thoroughly and carefully during and after manufacture so that they are surprisingly uniform—much more so than automotive parts. J. F. Martin and R. A. Miller² stated that one of the air lines replaces valve rocker-arm bearings after 1,000 hr, pistons after 2,000 hr, and cylinders after 2,500 hr of operation in the engine regardless of the

appearance of the parts. A complete bookkeeping system makes it possible to do this. Thus this air line is able to prevent most types of part trouble by replacing parts before they cause difficulty. By this method of rigid control, it established a record of 5,000,000 engine operating miles without mechanical trouble sufficient to cause premature removal of an engine from an airplane. When one considers that air-line engines are removed regularly only once every 600 to 700 hr, this is a splendid record and shows what a first-class maintenance department can accomplish.

References

1. WHITLOCK, M.: Limiting Factors on Overhaul Periods for Aircraft Engines, *S.A.E. Trans.*, vol. 51, 1942.
2. MARTIN, J. F., and R. A. MILLER: Preventive Maintenance in Airline Service, Paper presented to Metropolitan Section, S.A.E., January, 1941. Not published.
3. Battelle Memorial Institute: "Prevention of Fatigue in Metals," 1st ed., John Wiley & Sons, Inc., New York, 1941.

CHAPTER XIV

LABORATORY TESTING

Most of the test work on aircraft engines is carried out on test stands. Not only can an engine be more easily installed and the operating conditions more easily controlled on a stand, but the running expense is much less than in an airplane. Further, any operating troubles during tests would probably result in forced landings if the tests were carried out in an airplane. The nature of laboratory tests as well as the procedure and test equipment employed are complex. Although many do not realize it, the proper conduct of a test often requires as much engineering background on the part of the engineer in charge as design work. Such a background can be obtained only from much practical test experience. In this chapter, only the essential elements of the problem will be discussed.

TYPES OF TEST

The Run-In.—By far the most common type of laboratory test is the *run-in*. This must be given an engine each time it is rebuilt after new parts are installed. In a run-in, the speed and power of the engine are gradually increased from an idle to rated power, the duration of the run usually being 3 to 8 hr. The object of the run-in is to increase the speed and load gradually so that each bearing surface will adjust itself to fit the contours of the mating surface. Minute high spots should be worn away as the run-in progresses. In aircraft engines, the principal parts that require a "run-in" are the piston rings, cylinders, connecting-rod bearings, and plain main bearings.

There are several types of run-in. The first is the *green run*, which is given the engine by the manufacturer after it has been assembled new. After this initial run, the engine is torn down and inspected. If the parts are in satisfactory condition, the engine is rebuilt and given a *final run*, after which it is ready for installation in an airplane. If the engine parts were not in satisfactory condition after the green run, the engine is subjected

to a *penalty* test and again torn down. If the parts are then satisfactory, a *penalty final* test is run. Data are recorded on log sheets at intervals of about 15 min all through the tests. These are checked to make certain that the specific fuel consumption, the oil flow and heat rejection, and other factors are within the required limits. A calibrated test club may be used to check the power output, or, if the test is run on a dynamometer, the power may be measured. The engine is also checked for other signs of trouble, such as oil leaks. If everything is satisfactory, the engine is ready for use.

These run-ins are given to engines before they leave the manufacturer's plant. At overhaul bases, engines are given a routine run-in after each complete teardown and overhaul. This run-in is usually similar to the green run. After it has been completed, the engine is ready for installation in an airplane.

If an engine is to be packed or stored after a run-in, it is usually *run out* on clear, *i.e.*, unleaded, fuel. As pointed out in the chapter on Fuels and Lubricants, this is done to prevent corrosion, which would result from deposits of the products in leaded fuel.

Some manufacturers make the first part of the green run on a small stand that motors the engine over for a few hours. The only connections needed are the oil lines and the driving coupling. This method gives the bearing surfaces an opportunity to adjust themselves before the engine is operated under its own power. The portion of the run-in made under power is thus shortened.

The run-in is the simplest type of test. For air-cooled engines, it requires only a stand on which the engine may be mounted, a four-bladed wooden propeller to absorb the power output of the engine and send a cooling blast of air over the cylinders, controls, and plumbing for the oil and fuel lines and the gauges. A sound-proofed cell in which the engine can be mounted is desirable, while other equipment may be added so that additional data of special importance may be obtained during or immediately after the run-in.

Calibration Tests.—When a new model engine is brought out, it must be subjected to a calibration to determine its capabilities and to obtain the data from which performance charts may be constructed. Such a test is run on a dynamometer stand, on which the horsepower output is measured by a dynamometer.

Much more in the way of instruments and equipment is installed than would be needed for a run-in, and therefore a more complete picture of the conditions prevailing throughout the engine may be obtained. Minor changes in any model engine also usually require a calibration so that their effect may be determined. Further, contract requirements are often such that the manufacturer must run in on a dynamometer a certain portion of the engines he delivers. The data from each run-in are checked with the performance chart for that model engine to make certain that the engines built in production deliver the power they should.

Carburetion Tests.—Contracts usually call for certain carburetor metering characteristics. As pointed out in the chapter on Carburetion, these may be found by conducting a test on a stand provided with a means for measuring the flow of the air consumed by the engine.

Endurance Tests.—The parts of an aircraft engine must be capable of standing up under service operation. It is necessary to carry out a very large amount of testing on an engine model in order to obtain a refinement of part design such that the engine may be operated for long periods without a loss in dependability. Accelerated tests are run at high power for 50 hr or more to establish the durability of any or all engine parts. Such tests are hard on both the engine and the test equipment.

"Type" Tests.—A "type" test must be run on an engine before it may be used in Army, Navy, or commercial airplanes. Such a test consists of at least 150 hr of running. It includes a complete calibration, as follows: 10 hr at take-off power; 40 hr at rated power or at 91 per cent take-off power, whichever is the greater; 10 hr at overspeed; and other miscellaneous requirements. The take-off test may be run continuously, or it may be made up of 120 five-minute periods run alternately with 120 five-minute periods at an idle. Similarly, the overspeed, or *dive*, test may be broken up into a series of 30- or 60-sec periods at the specified overspeed, followed by 5 min of idling. These tests may be run at Wright Field for the Army, the Naval Aircraft Factory for the Navy, or at the engine manufacturer's plant.

Vibration Tests.—It is necessary to run tests to determine the vibration characteristics of each engine model and to make cer-

tain that the vibration is within acceptable limits throughout the operating range. These tests are usually carried out with a flight propeller of the model to be installed on the engine in the airplane. The special equipment necessary, other than a test stand large enough for the propeller, is usually small in size and readily installed.

Single-cylinder Engine Tests.—A large part of basic research and development work is concerned only with the cylinder assembly and pistons, and thus tests may be run on a single-cylinder adaptation of the full-scale engine. All parts used are full size; but only 1 set must be made instead of the 9, 14, or 18 sets required for a full engine. Part durability, special valve mechanisms, cooling characteristics, etc., may be tested on a single-cylinder unit. The tests are usually made on a small dynamometer stand.

Specialized Tests.—Other specialized test work includes fuel rating, oil rating, supercharger, oil flow, and other testing. These tests may be run on conventional test stands or may require special equipment. Air-flow characteristics of valve ports and air scoops, for example, can be found from tests that require only a blower, metering orifices, and some manometers.

TEST STANDS

Stands for Use with Test Clubs.—The simplest type of test stand is one in which the engine is mounted on a rugged supporting structure and loaded with a test club, which is a four-bladed wooden propeller. The engine is usually housed in a tunnel, which may be open at the ends or may have large stacks at either end to reflect the sound upward. These stands may be soundproofed, a measure that is absolutely necessary if many stands are grouped together. If properly soundproofed, the noise level in the control rooms may be made low enough to permit conversation even while the engine is operated at high power. Rigid frames bolted to a bedplate or embedded in a reinforced-concrete base are often used. Figure 146 shows a production engine test stand of reinforced concrete at the Allison factory. It has a rugged construction, free of vibration troubles. Whether the supporting structure is of steel or concrete, if it is extremely rigid the engine should be mounted on properly designed rubber bushings to isolate its vibration from

the rigid stand. The engine is often bolted to a short intermediate frame, or mount, which is in turn bolted to the stand and serves as an adaptor. It makes possible operation of several

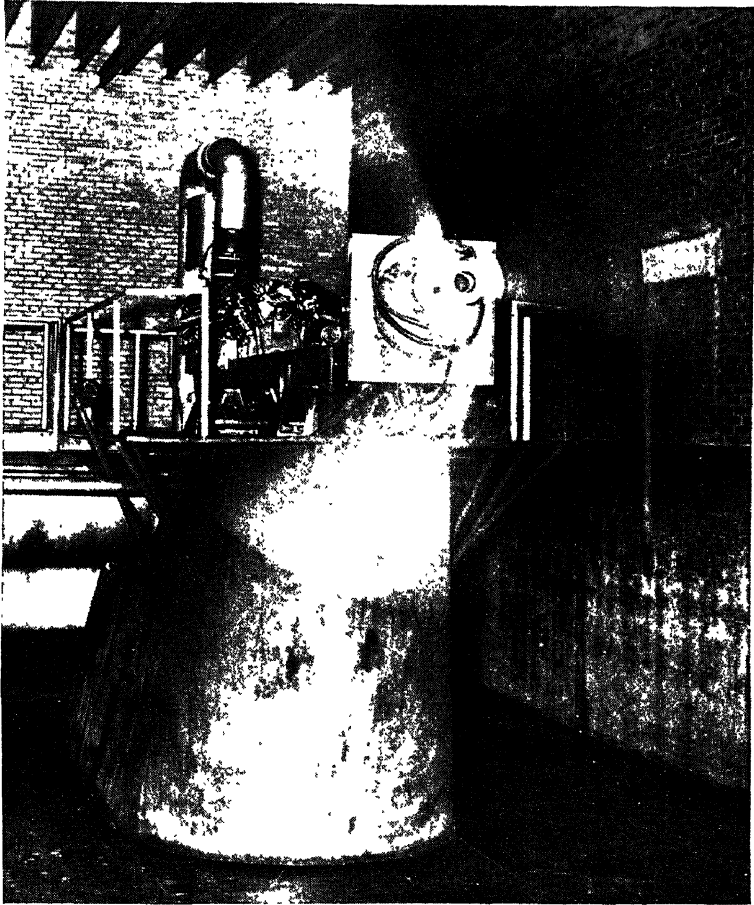

FIG. 146.—Allison engine production test cell showing a stand of reinforced concrete. (*Butner, S.A.E. Trans. vol. 50, 1942.*)

types of engine on the same stand without difficult mounting changes.

Cable Stands.—Test stands suitable for development work involving operation with a flight propeller are larger but otherwise are built in much the same way as many of those intended for production work. Figure 147 shows a view of an N.A.C.A. test stand. Note the honeycombing of special sound-absorbent

block at the end of the tunnel. A roll-type steel door may be lowered to close the opening. Figure 148 shows a view of the interior of one of the tunnels. This shows an engine support commonly used, the so-called *cable stand*. The engine is mounted on a large steel drum suspended on 12 tightly drawn steel cables. Thrust loads are taken by a thrust strut or by other steel cables. All cables must be kept tight, or severe vibration may occur during operation.

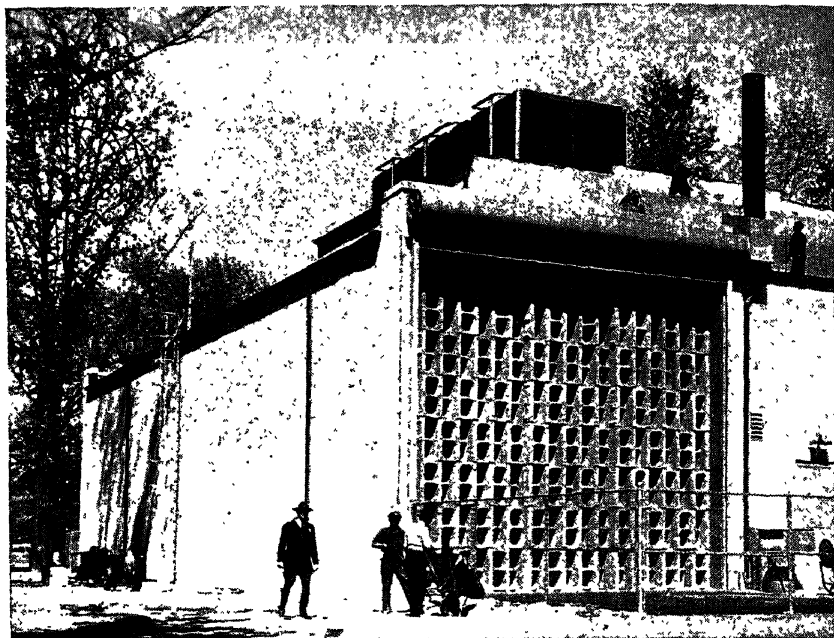

FIG. 147.—An N.A.C.A. test stand for testing large engines loaded with flight propellers. (*Aviation.*)

Dynamometer Stands.—Basic calibrations, as well as a great deal of other test work, must be carried out on a dynamometer stand. On this the engine power is absorbed by an electric dynamometer, a water brake, or a combination of both. These machines make possible the determination of the engine horsepower output from the torque reaction of the dynamometer housing measured with a large scale. The engine rpm as measured by a counter and the *dynamometer constant* (a factor that combines the length of the dynamometer arm acting on the scale with the 33,000 ft-lb equivalent of the horsepower), together

with the dynamometer-scale load, gives the horsepower output of the engine.

If the engine is water-cooled, the problem of cooling is ordinarily simple. Water from the city mains may be supplied to the cooling jackets and the heated water drained off after leaving the

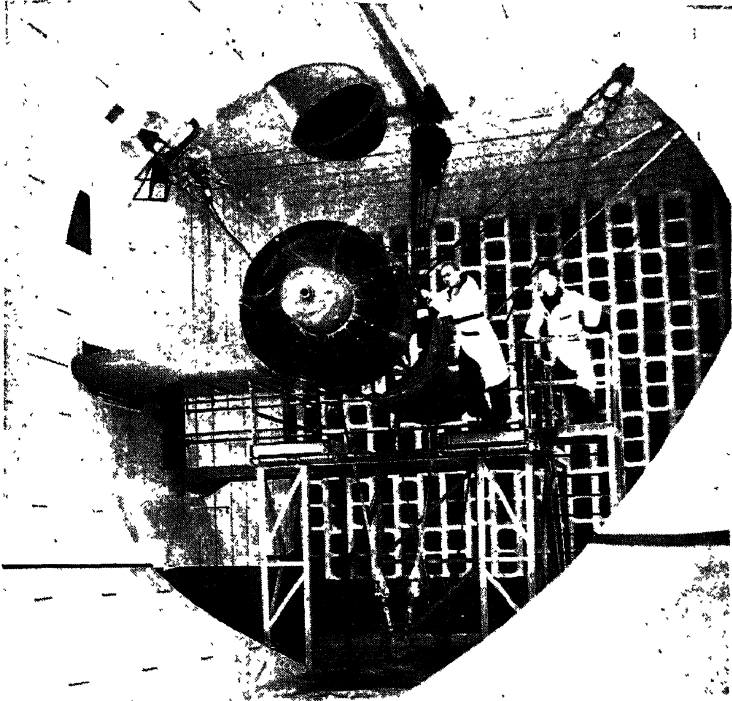

FIG. 148.—Interior view of the tunnel of the cable stand in Fig. 147. The engine is shown idling. (*Aviation.*)

engine. If a prestone-cooled engine is used, a system must be provided for circulating the prestone through a cooler, the cooling medium there being air or water. Air-cooled engines present some difficult cooling problems, for a large volume of air must be forced over the cylinder cooling fins. This ordinarily requires a blower driven by a motor having a capacity equal to about 10 per cent of the horsepower of the engine being tested. Further complications are presented by the duct work. Air-cooled engines are designed to receive the cooling air from the front. The shaft

connecting the engine to the dynamometer must be made long enough so that the duct from the blower may direct the air into the cylinders from the front. Figure 149 shows a dynamometer stand, with an air-cooled radial engine installed, as viewed from the rear of the engine. The cooling air is brought vertically upward through the floor from the blower room below and is

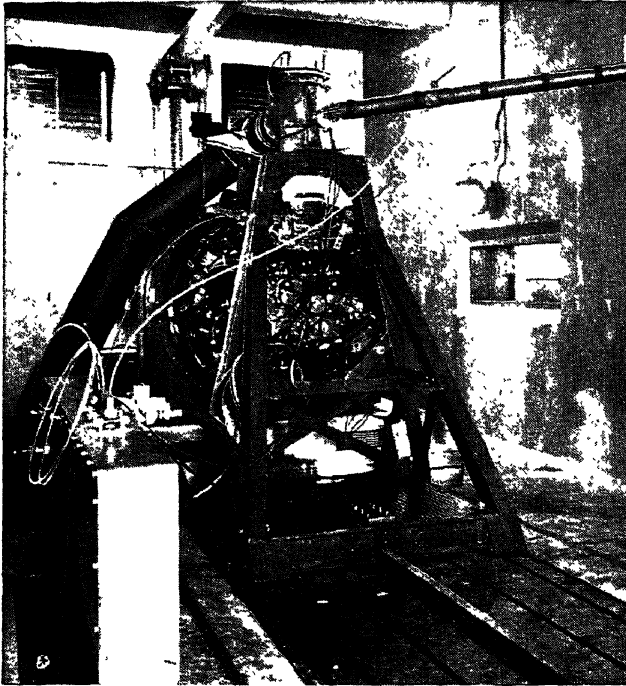

FIG. 149.—Rear view of an engine coupled to a dynamometer showing a rigid structural-steel stand. (*Wright Aeronautical Corp.*)

directed rearward by an elbow just in front of the engine. The duct extending upward from the floor at the left is about 1 ft in diameter and supplies air to the carburetor.

Power-recovery Test Stands.—The tens of thousands of horsepower expended in the production test stands of the large aircraft-engine plants usually goes to waste. A number of manufacturers have made an effort to convert some of this power into useful electrical energy. The most difficult element of the problem is the fact that the run-in must be conducted along a propeller-load curve, or something close to it. This means that operation must

be at a wide range of speeds and powers. Figure 150 shows a satisfactory arrangement. It consists of a hydraulic coupling and a synchronous generator. At engine speeds below the synchronous speed, the generator is locked while the hydraulic coupling is used to absorb the power, which is, of course, lost. At speeds equal to the synchronous speed, the generator is unlocked, brought up to speed, and coupled into the electric power line. At higher engine speeds, the generator is kept at the synchronous speed and the hydraulic coupling is again allowed to slip. The result is that some of the power is wasted in that range.

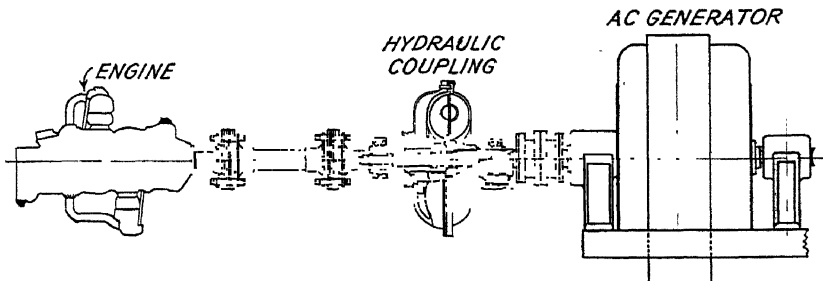

FIG. 150.—Schematic diagram of a power-recovery test stand. (Aviation.)

Test stands of this type will convert into electrical energy about two-thirds of the horsepower-hours developed in the course of a run-in. If the engine is air-cooled, a considerable amount of power must go to the cooling blower so that the net amount of power saved is only about one-half the power developed by the engine during the course of the test. The high initial cost of the equipment, the difficult problems of control, and the amount of time the stand is idle while engines are being changed are disadvantages of the system.

Use of Test Stands.—Dynamometer test stands are used for virtually all engine-calibration work, some carburetion work, and many special tests on air-cooled engines. They are widely used for all types of liquid-cooled-engine testing since stands designed for liquid-cooled engines do not require expensive cooling blower equipment. Test stands on which the engine is loaded with a propeller are used for air-cooled-engine testing for run-ins and endurance, carburetion, vibration, and miscellaneous testing. They are especially suited for this work because a relatively

inexpensive propeller serves both to cool and to absorb the horsepower of the engine.

TEST EQUIPMENT

Cowling.—A simple cowling is ordinarily used for air-cooled engines to increase the air flow over the cylinders. This is in the form of a sheet-steel ring 1 or 2 ft. wide and the diameter of the engine. It is wrapped around the rocker boxes, where it is drawn up and held by closing a gap in its circumference. A cowling of this type may be seen in Fig. 148. As a rule, no cowling is used on liquid-cooled engines.

Exhaust Systems.—Exhaust systems are usually simple, for only short stacks intended to carry the exhaust gases away from the cylinders are required. Stub stacks are desirable because they make it possible for the test personnel to watch the exhaust flame of each cylinder during the test. The significance of these flames will be mentioned later. The propeller or cooling air blast carries the exhaust gases off. Since liquid-cooled-engine dynamometer stands are ordinarily in a closed room, an exhaust manifold must be installed on the engine to collect the gases and discharge them into ducts provided for the purpose. These often contain some type of muffler to reduce the exhaust noise. Since appreciable exhaust back pressure would impose a penalty on engine performance, the exhaust systems of such stands are often equipped with blowers or fans to draw off the exhaust gases. The blowers have the additional advantage that they prevent the escape of carbon monoxide from leaks in the exhaust manifold into the room. The gas would be likely to escape if the pressure in the manifold were above the atmospheric pressure in the room.

Fuel System.—Fuel lines must be provided to deliver gasoline to the engine. It is often necessary to have several different fuels available. A flowmeter or a weighing scale is provided in the supply system to make possible the measurement of fuel flow to the engine. Valves, pressure and temperature gauges, and possibly a cooler are also needed in the fuel system, together with a float tank or some other means of providing fuel at a constant pressure to the engine fuel pump.

Oil System.—An oil system providing a storage tank, piping to the engine, a return line from the engine scavenge pump, a

cooler to control the temperature of the oil supplied to the engine, and some sort of oil strainer is needed. A part of this plumbing is shown in Fig. 151 for a stand similar to that in Fig. 146. Valves, a scale to make possible measurement of oil flow and engine oil consumption, and gauges giving the temperature of the oil at the inlet and outlet of the engine and at the outlet of the cooler are usually provided. A pump to circulate the oil during the cleaning of the system and for circulating and warming the oil before starting in cold weather is also ordinarily installed.

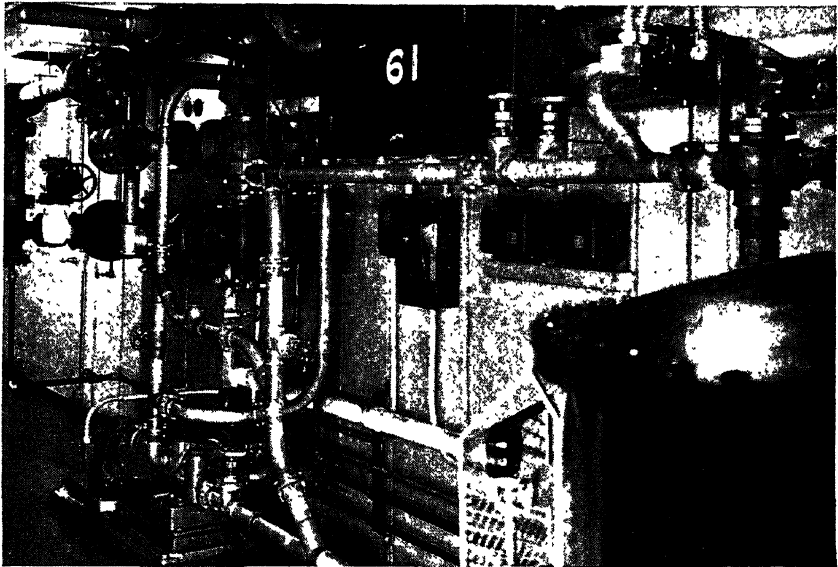

FIG. 151.—A portion of the plumbing beneath the control room of a test stand such as that in Fig. 146. (*Buttner, S.A.E. Trans., vol. 50, 1942.*)

At least one and more often two or three oil pressure gauges with a line to the engine for each are required.

Induction System.—To make possible control of the temperature and pressure of the air supplied to the carburetor, a blower, a heat exchanger for use as either a heater or a cooler, and the accompanying duct work are normally included in the test-stand equipment. If carburetion work is to be done, an "air bottle" with a set of orifices may be installed at the blower inlet and a draft gauge in the control room. A valve for controlling carburetor air inlet pressure (scoop pressure), a carburetor air temperature gauge, valves for controlling the carburetor air

temperature, and manometers to indicate the scoop pressure, manifold pressure, and, in some cases, other pressures in the induction system of the engine itself are lesser items normally found.

Control Bench.—The control bench for a test stand like that in Fig. 146 may be seen in Fig. 152. In this case the instruments are grouped around a window through which the engine may be

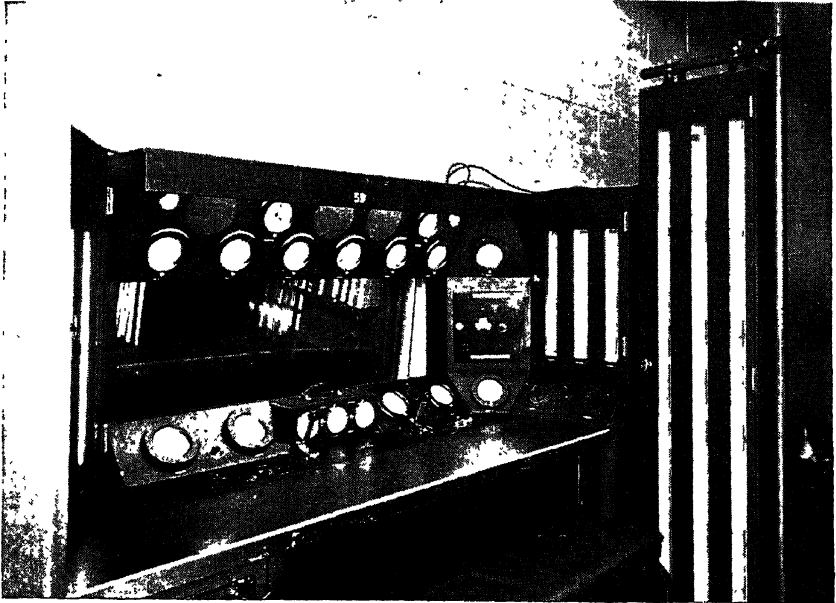

FIG. 152.—The control bench of a test stand like that in Fig. 146. (*Buttner, S.A.E. Trans., vol. 50, 1942.*)

watched during the course of the test. The throttle and mixture-control levers are located one at each end of the tachometer, counter, and timer unit, which may be seen at the center of the control bench just in front of the window. On either side of these, control switches for various items of equipment are mounted in the top of the control bench. The potentiometer with a thermocouple selector switch is in the corner at the right end, while pressure and temperature gauges as well as manometers are placed at convenient points as shown in Fig. 152. Figure 153 shows a control bench for a dynamometer test stand. Note the complete set of instruments and the additional control wheel, handles, and levers.

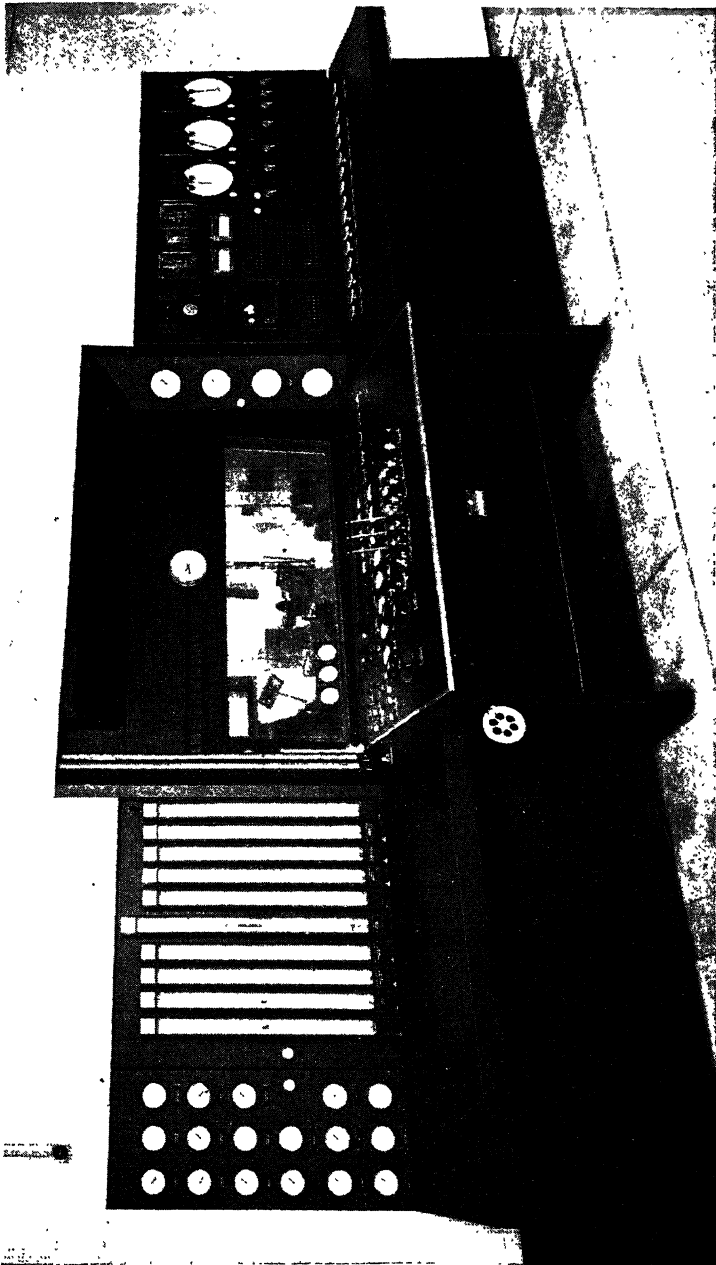

Fig. 153.—The control bench for a large dynamometer stand for testing experimental engines. (Allison Division, General Motors Corp.)

DYNAMOMETERS

The dynamometer is the most intricate and expensive piece of equipment used for aircraft-engine testing and so deserves special attention. Until recent years, relatively few dynamometers intended to absorb 1,000 hp or more had ever been built. Much development work had to be done to make suitable machines available. Direct-current electric dynamometers in units capable of absorbing as much as 500 hp have been widely used for many years because of their flexibility and ease of control. Larger units are extremely costly, so much so that the less expensive, simpler, and more compact water brake has been employed for many of the larger test stands. A water brake capable of absorbing 4,000 hp takes up no more floor space than a 400-hp electric dynamometer and requires no switchboard or large batteries of grids. Since about 1940, still another machine, the eddy-current dynamometer, has come to be used. It is less expensive than the d-c machine and yet is easily controlled.

D-c Electric Dynamometer.—The d-c electric dynamometer is a generator that may also be used as a motor. The housing is mounted on ball or roller bearings to permit it to rotate freely about the axis of the armature shaft except insofar as it is restrained from turning by a linkage connected to a large scale. The reaction of the housing on the scale is proportional to the torque transmitted to the dynamometer shaft. Even the friction in the armature-shaft bearings is included, for the torque acting on them is transmitted to the housing.

The machine may be started up as a motor and used to drive the engine. If the test requires it, the engine may sometimes be driven at diving speeds. Usually, however, the engine is started and operated under its own power. When it is firing smoothly, the dynamometer may be switched from motor to generator operation so that the engine may be loaded. The dynamometer speed and load can be varied by manipulation of the field rheostat, which governs the strength of the field. Both because of the space required and in the interests of safety, the control panel containing the necessary switching equipment is usually located where it will not be in the way. The "start-stop" switch together with the field rheostat are placed in the control bench so that an operator there may start or stop the dynamometer

when it is used as a motor and control the speed when it is used as either a motor or a generator. Directions for the operation of this type of dynamometer are given in the Appendix.

The Eddy-current Dynamometer.—Figure 154 shows an eddy-current and a d-c dynamometer combined in one unit. The

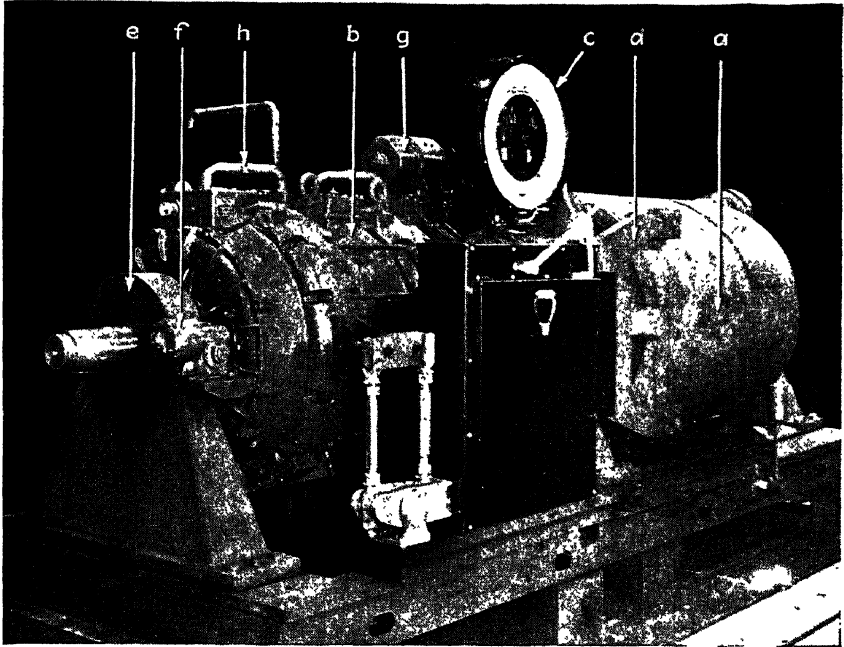

FIG. 154.—Large dynamometer consisting of a d-c machine (a) coupled to an eddy-current brake (b) on a common bedplate to make a unit having a power-absorption capacity of 4,000 hp at 2,000 rpm. The scale (c) is connected to the eddy-current brake by means of a reversing linkage. The arms (d) transfer the torque reaction on the d-c stator to the eddy-current brake. Each machine is carried in a pair of trunnion bearings (e) with motor-operated rotators (f). An exciter (g) is belt-driven from the shaft of each machine. The cooling water for the eddy-current brake enters the inlet (h) through a loop of flexible hose and discharges into stationary funnels. (*Aviation.*)

high-power absorption capacity of the eddy-current machine coupled with the flexibility of the d-c dynamometer gives an excellent unit for aircraft-engine test work. The smaller housing shown at the left of Fig. 154 contains field coils between which rotates a large hollow rotor. The eddy currents set up in the latter as it is rotated cause a torque reaction on the housing. Water is circulated through the rotor to carry off the heat generated by the eddy currents. The load is controlled by varying

the strength of the field. It is interesting to note that the eddy-current machine in Fig. 154 will absorb four times the power of the d-c unit. Further, it does not need bulky resistance grids, which would require a sizable shelter arranged to give good air cooling.

The Water Brake.—The Froude dynamometer is one of the best water brakes available (see Fig. 155). As in the case of the d-c electric dynamometer, it is mounted in a cradle so that the entire reaction to the torque input from the shaft can be trans-

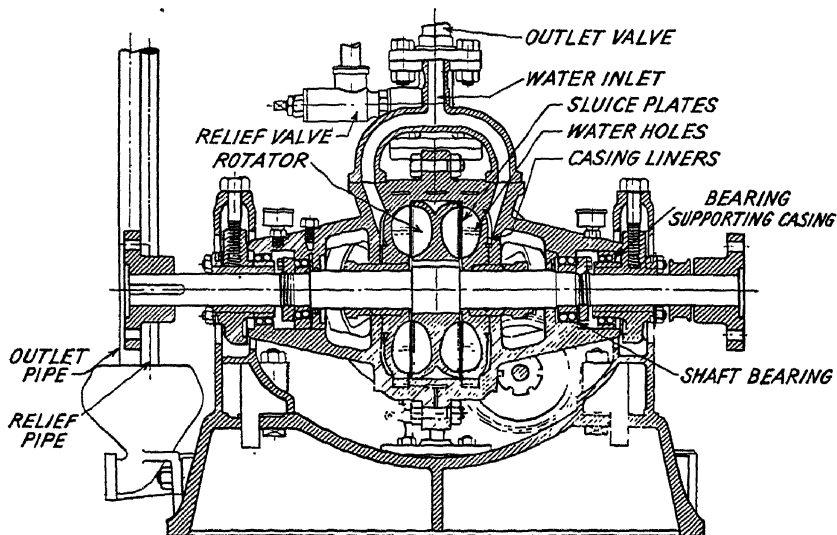

FIG. 155.—Water brake of the Froude type. (Judge, "The Testing of High Speed Internal Combustion Engines," Chapman & Hall, Ltd., London, 1932.)

mitted to a scale. The engine may be coupled directly to the shaft, on which is mounted the rotor. The latter revolves inside the casing. Water circulated through the casing provides hydraulic resistance and carries away the heat developed from the power absorbed by the brake. Frictional losses in the bearing or in the packing glands at the end cause no error, for the resulting torque is transmitted to the housing.

In each face of the rotor are pockets of semielliptical cross section divided from each other by means of vanes. The internal faces of the casing are also pocketed in the same way. The rotor discharges water at high speed from its periphery into the casing pockets, from which it is returned at a reduced speed into the

rotor pockets at a point near the shaft. Thus the pockets in the rotor and the casing together form elliptical receptacles in which the water courses at high speed. The power is absorbed by the eddies and friction in the violently turbulent water. The load on the engine is controlled by thin plates, which may be moved into the space between the rotor and the housing to mask off the pockets. This will reduce the amount of water circulation and thus the frictional losses.

The quantity of water required to carry away the heat generated can be easily calculated. Each brake horsepower absorbed generates 2545 Btu per hr, or 42.4 Btu per min, and nearly all this heat passes into the cooling water. The quantity of water supplied to the brake must be sufficient to prevent the temperature at the outlet from rising above 180°F. A lower temperature is more desirable if plenty of water is available. On the basis of a water inlet temperature of 50°F, at least 2 gal of water per brake horsepower hour should be available.

ENGINE OPERATION AND TROUBLE SHOOTING

Although the material included in the following section was intended to apply to engines installed on a test stand, in most cases it is equally applicable to engines installed in airplanes.

Engine Installation.—Before an engine may be run on a test stand, it must be properly installed. Gasoline and oil supply lines, fuel and oil pressure gauges, manifold pressure and other manometers, temperature gauges, thermocouples, and other instruments must be connected. Provision for cooling and loading the engine must be made. Different models of engines usually require different adaptors to connect them to the test-stand carburetor air duct, coolant system, etc. Care must be taken during the installation to ensure the security of all fastenings, to keep all oil and fuel lines clear of the exhaust system, and to mount the controls so that they will operate smoothly without binding or interfering with any other equipment. In short, good sense and foresight should be exercised to minimize the likelihood of trouble during operation. All equipment should be examined each time before installation to make certain that it is in good condition.

Preparations for the Start.—Before starting the engine, valves in the oil and fuel systems should be checked to make certain

that they are properly set. The controls should be tested to check the direction in which they should be moved (usually it is possible that the throttle, for example, might be either open or closed for a given setting of the control handle in the control room) and to make certain that both extreme positions at the engine can be obtained. If a dynamometer is used, it should be locked to take the starting loads off the knife-edges in the scale linkage. If a cooling blower is used, it should be started. When all is in readiness, the last fuel valve may be turned on and adjustments made to give the correct fuel pressure at the carburetor.

Starting.—To start the engine, it is necessary to “turn it over” with the dynamometer on a d-c electric dynamometer stand or with a conventional starter mounted on the engine. Before turning on the ignition switch, a radial or an inverted in-line engine should be turned over a few revolutions, either by hand or with the available means of starting, to clear the lower cylinders of any oil or gasoline that may have accumulated there. The ignition switch may then be turned on and the engine motored over to start. As pointed out in the chapter on Carburetion, fuel-priming practice varies with the carburetor. Engines are usually equipped with priming systems that make it possible to spray gasoline directly into the intake manifold. Small steel tubes fed by a little electric pump or a single plunger-type hand pump carry the gasoline to one or more points in the induction system so that a suitable fuel-air mixture may be obtained there before an attempted start.

When the engine starts, care should be taken to keep the speed in the idling range for a few minutes at least. The oil pressure should be watched—it should come up to the proper value within 30 sec, although it may take somewhat longer in cold weather. If the oil pressure gauge does not register, the engine should be stopped immediately and the cause investigated. From the time the engine is started until it is stopped, all gauges and instruments, as well as the engine itself, should be watched to be certain that everything is as it should be. After the engine has been started and is operating satisfactorily, the spark plugs and the ignition switch should be tested to make certain that they are functioning. This check should be repeated at intervals of not more than 4 hr throughout the test. (See page 153 for details on the procedure.)

Curves Used for Testing.—Probably the most common curve run is the propeller-load curve. This is approximately that which would be obtained with an engine operating with a fixed-pitch propeller, *i.e.*, the power is proportional to the cube of the speed. Run-ins are commonly made on a propeller-load curve. Carburetion and vibration tests are also commonly made along a propeller-load curve, for it is typical of the range of actual service operation. Other curves frequently used are the constant-speed manifold pressure curve in which the engine is held at a constant speed and the horsepower output, or load, varied; the constant-bmep curve in which the bmep is held constant and the speed varied; and the constant-power mixture-control curve in which the engine power is held constant while the fuel flow through the carburetor is varied. Obviously, the latter curves must be run on a dynamometer or with a variable-pitch propeller.

Conduct of the Test.—Since test-stand operation is expensive, every minute should be used to the best advantage. A definite operating schedule is usually made out in advance. For run-ins, this may be on a standard form that specifies speeds, powers, and/or manifold pressures, fuel flows, and operating temperature limits. In the case of calibration or carburetion work the various curves to be run off, together with the operating limits, are listed but may be deviated from at the discretion of the engineer in charge. If a curve is being run, the data are usually plotted as the work progresses. If the points are not consistent, either with each other or with the results expected, the data can be checked immediately by repeating the point or points in question.

Normally it is necessary to keep most operating conditions as nearly constant as possible while allowing a few items to vary so that their relationship will be as accurately defined as possible. Oil temperatures and pressures, carburetor air inlet temperature and pressure, cylinder-head temperature, fuel temperature and pressure, etc., are ordinarily all kept nearly constant. They are usually kept to values that make the results comparative with other tests, or with service conditions.

If the engine is being run with a test club, the only control one has on the speed and power is the throttle, for both speed and power increase along a propeller-load curve up to full throttle. If the engine is run with a variable-pitch propeller or on a dynamometer, the load, or torque, restraining the engine may be

varied. Thus the speed and power output of the engine should be controlled by operation of both the engine throttle and the propeller or the dynamometer controls.

Stopping.—If the engine must be stopped abruptly, the ignition switch may be cut. This is not necessary as a rule, however. The engine is usually idled down and allowed to cool off slowly for a few minutes and then stopped by shutting off the fuel supply, usually at the carburetor. This is a safety precaution so that no combustible mixture will remain in the cylinders to start the hot engine if the propeller should be moved. When the engine has stopped, the ignition switch should be turned to the “off” position; the valves in the oil and fuel lines closed; and, on a dynamometer, the switches on the control panel opened, the dynamometer locked, and the cooling blowers (if present) turned off. On all types of stand, water and/or steam to the oil, fuel, and carburetor air “coolers” must be shut off, and other steps taken that are indicated for the individual stand.

Trouble Shooting.—Engine testing is often accompanied by troubles of one sort or another. Starting troubles are annoying, especially on test stands like that in Fig. 147. During cold weather the high viscosity of the lubricating oil, coupled with the lowered volatility of the fuel, makes starting difficult. It may sometimes be necessary to put a hood over the engine and heat the enclosure thus formed with a small stove or, if possible, with hot air from the carburetor air duct. In general, if the engine shows no signs of starting after a reasonable number of attempts under normal conditions, it is well to check the primer line to see whether or not fuel is getting to the engine. If this condition is satisfactory, a check should be made on the ignition system. If a few plugs are removed and found to be clean and a spark may be obtained when motoring the engine over, this system too is probably in good condition, and further attempts to start should be made. In general, if the engine is getting fuel and there is a spark at the end of the compression stroke, the engine should show signs of starting if it is motored over at a reasonable speed. If it shows no signs whatever of a cylinder firing after repeated attempts, a thorough investigation may be necessary. (Cold weather may cause exceptional starting troubles.) If the engine fires erratically or spasmodically, its actions should give some indication of the trouble.

In a machine as complex as an aircraft engine, innumerable things may be wrong. Valve and ignition timing, and the carburetor are a few of the complicated mechanisms that might be improperly set.

In operating, it is important to watch for anything that might be wrong with the engine. While the engine is running, probably the most important indications of trouble are the oil pressure gauge, the temperature of the oil leaving the engine, cylinder-head temperature, and, if available, crankcase pressure. If the oil pressure falls off, an important bearing may have been "washed out," an obstruction may have entered the oil system, an oil line may have broken, or something else equally dangerous to the engine may have occurred. If the oil-out temperature becomes excessively high, this may also indicate a bearing failure (the temperature rises because of the increased friction) or it may indicate that the engine is not scavenging properly and the oil is remaining in the crankcase so long that it becomes overheated. The cylinder-head temperature must be kept below 400 to 500°F depending on the test, partly because lubrication of the piston and valve mechanisms will otherwise fail and partly because the aluminum cylinder head is only about three-fourths as strong at 500°F. Crankcase pressure, if measured, is an indication of both the condition of the piston rings and cylinder walls and the manner in which the oil in the engine is being removed. A high crankcase pressure may indicate a scored cylinder and/or piston, badly worn piston rings, or improper scavenging of the oil.

If stub stacks are used, the exhaust flames are an invaluable aid. A pale-blue carbon monoxide flame like that of a Bunsen burner will normally appear. The length depends on the fuel-air ratio. Rich mixtures may often give flames 2 ft. long, while best economy mixtures give scarcely any flame at all. Extremely rich mixtures cause "torching," *i.e.*, bright white, yellow, or reddish coloration and irregular flames, occasionally as much as 6 ft long. Stuck or worn piston or impeller oil seal rings will permit oil to pass into the combustion chamber. This oil burns relatively slowly and colors the flames a bright orange or sometimes red. If a cylinder becomes scored, so much oil will enter the combustion chamber that white smoke will come from the stack. Detonation shakes tiny particles loose from the com-

bustion-chamber walls. These will also color the flame an orange or red. The engine should be watched very closely as conditions likely to cause detonation are approached. If the clear-blue flames suddenly become filled with intermittent bursts of orange, light detonation is occurring at intervals. If detonation is allowed to become heavy, black smoke may appear.

After stopping, there are a number of means of checking for mechanical failure. The oil sump, into which drains the oil flowing through the engine, may be drained and the drainings examined for chips, *i.e.*, small particles of metal. Examination of these usually makes it possible to determine their source. Aluminum chips usually mean a scored piston; bronze chips indicate a bronze bushing or bearing. The oil strainers in the test-stand oil system may also be examined. The engine itself should be checked over after every stop to be sure the exhaust stacks are securely fastened, that there are no oil or fuel leaks, and that all lines, wires, and controls are secure.

The only good school for trouble shooting is actual experience. When trouble is encountered, all available evidence should be examined, including seemingly irrelevant material. The exact cause can usually be determined so that the proper decision may be made and appropriate action taken.

Reference

1. BUTTNER, H. J.: Production Testing Facilities of Allison Division of General Motors, *S.A.E. Trans.*, vol. 50, 1942.

PART II

Engine Installations

CHAPTER XV

GENERAL INSTALLATION CONSIDERATIONS

The installation of the power plant has become what is probably the most complex single problem in the design of a large modern airplane. It is not enough that a reliable engine be used

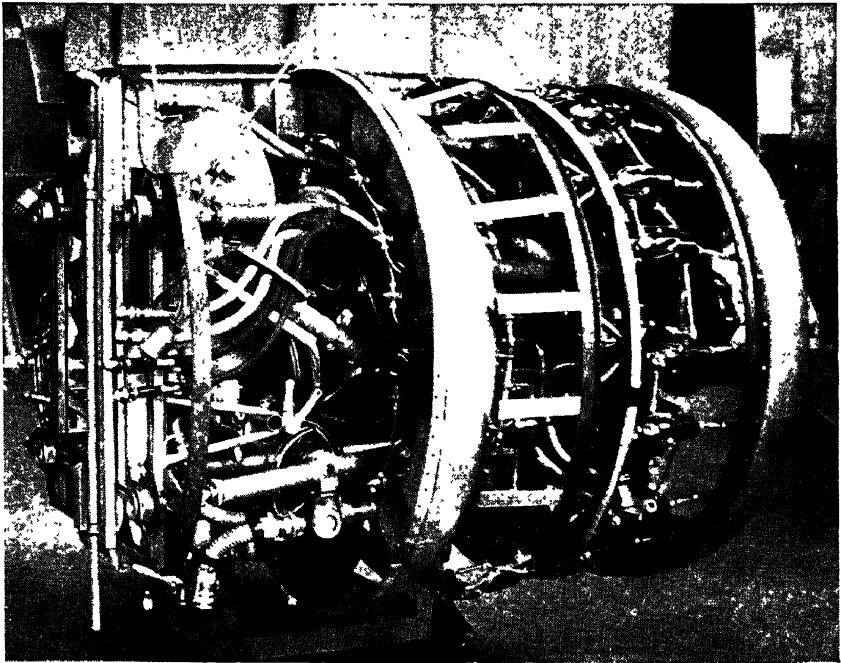

FIG. 156.—Junkers JU90 power-plant unit. (*Wright Aeronautical Corp.*)

—that engine must be properly installed, or a great deal of engine trouble may result. The amount of plumbing alone is amazing. Figure 156 gives some notion of the number of lines and fittings involved. Figure 157 shows side and rear views of one of the smaller engines, indicating the specific connections necessary. This plumbing must function faultlessly over a temperature range of $+110$ to -50°F , from sea level to the very

low atmospheric pressures of high altitudes, in dives and in violent maneuvers; it must withstand the pounding of engine vibration; and yet it must be light. The installation must provide the proper amount of cooling air flow over the engine under all flight conditions from take-off to long cruising descents and yet must impose a minimum amount of parasite drag. Then,

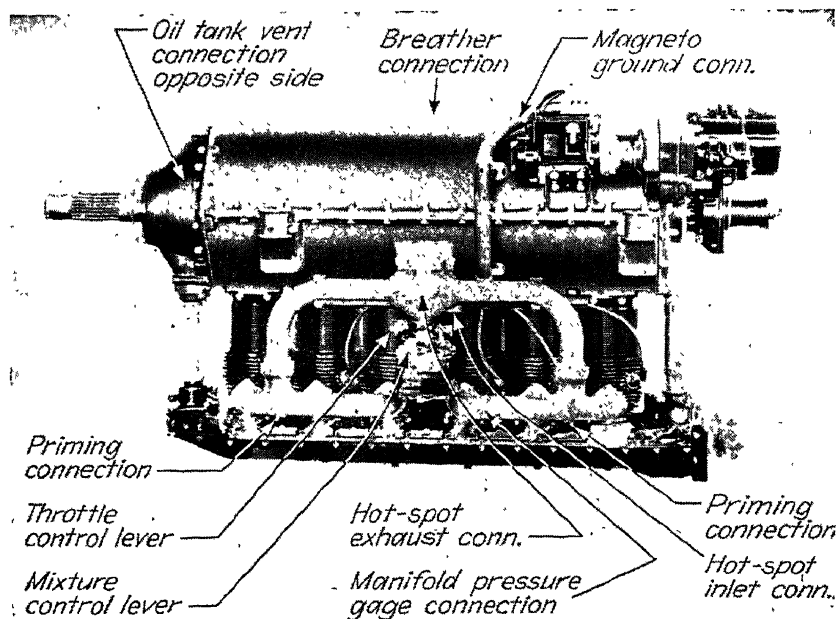

FIG. 157a.—Side view of a Ranger 6-440 C engine. (Ranger Aircraft Engines.)

too, provision must be made for maintenance. Not only must various points on the engine such as the spark plugs receive attention at regular intervals; fuel strainers, controls, fuel- and oil-pressure relief valves, and other items of equipment must be frequently cleaned, checked, and adjusted. A successful installation must make all such points readily accessible.

In short, the aircraft-engine installation offers many inter-related problems, each presenting difficulties and imposing limitations on other items. Taken as a whole, it is extremely involved, and yet the performance of the entire airplane hinges on the complete reliability of the engine installation under all flight conditions. The extent to which it achieves that relia-

bility depends on both the basic layout and the care and forethought given to each of hundreds of details.

Installation Components and Their Functions.—A brief enumeration of the elements of an engine installation may help to give perspective to the problem. Perhaps the basic item is the

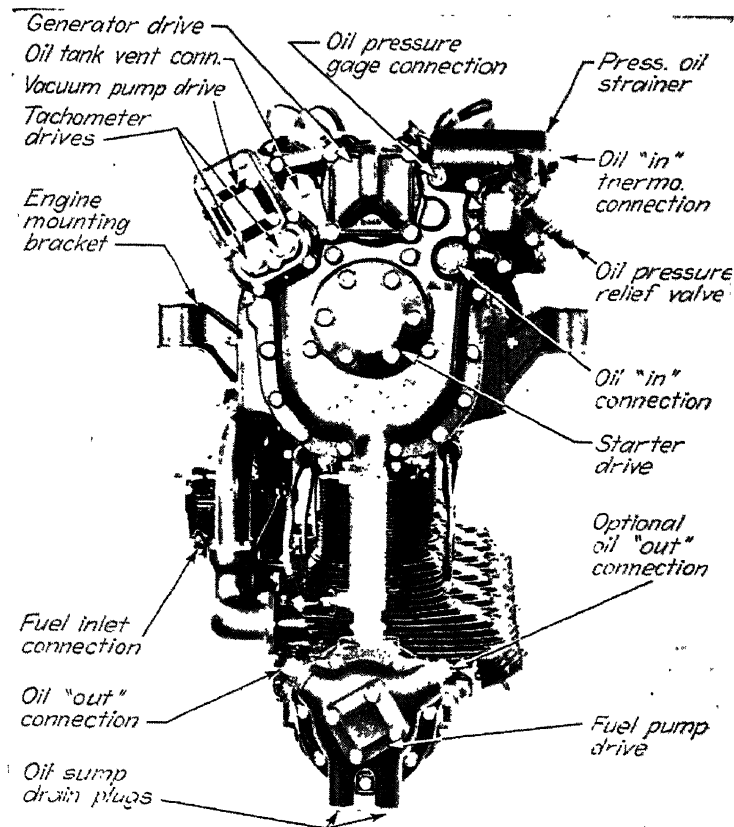

FIG. 157b.—Rear view of a Ranger 6-440 C engine. (Ranger Aircraft Engines.)

engine mount. This must provide a sturdy support for the engine, and yet insofar as possible it should isolate engine vibration from the airplane. It should be so planned that any of the accessories or other equipment mounted behind the engine may be removed without disturbing any other item and should permit easy removal of the engine itself from the airplane.

The cowling must house the engine, withstand relatively large air forces, provide for cooling the cylinders of air-cooled engines

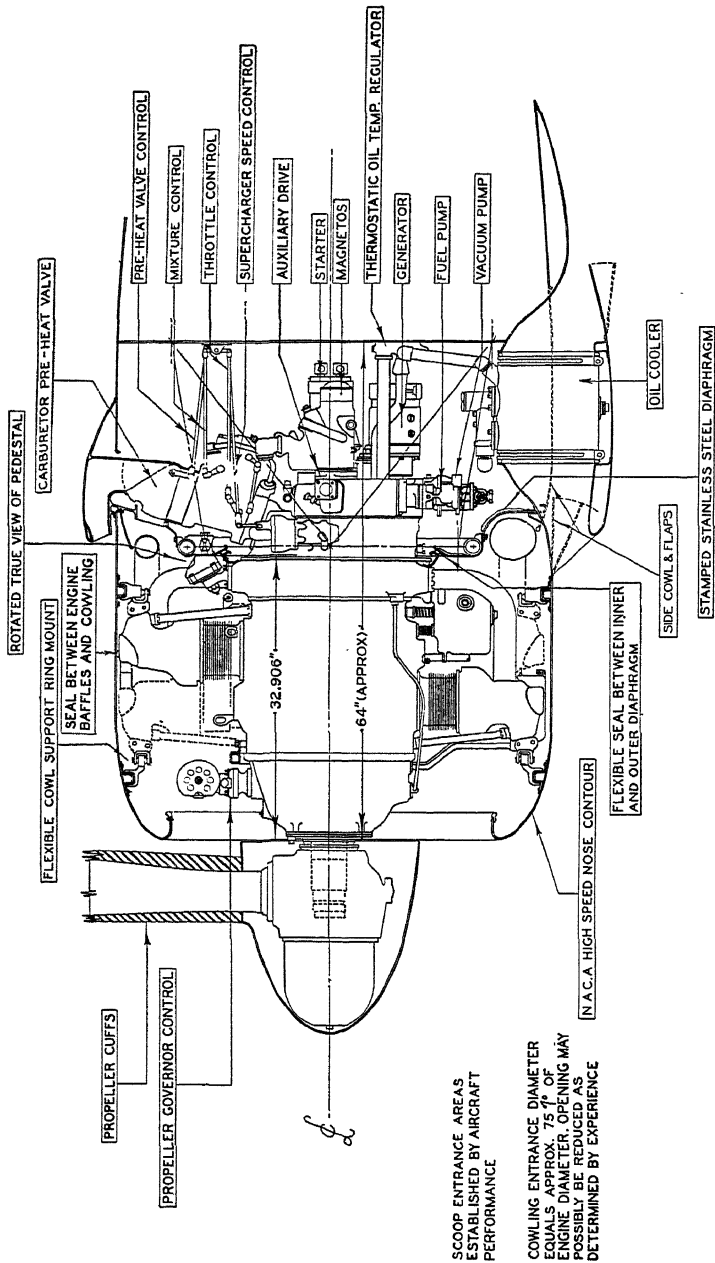

FIG. 158.—Longitudinal section through an engine installation forward of the fire wall. (Pratt & Whitney Aircraft.)

or the radiators of liquid-cooled engines, keep drag to a minimum, and yet be easily removable to give good accessibility to the engine and its equipment.

The fuel system must provide the engine with clean fuel from any of several fuel tanks and should not permit air or vapor locking of the fuel pump under any of a wide range of flight conditions. The oil system must provide the engine with a continuous supply of oil and must carry off the oil scavenged from the sump, cool it, and return it to the oil tank.

Clean air at the proper temperature must be supplied to the carburetor in a smoothly flowing stream at the carburetor inlet to ensure accurate carburetor metering. Temperature control of the carburetor air may include provision for heating to prevent ice formation in the induction system, or it may require intercoolers to reduce the temperature of air compressed and heated by an auxiliary-stage supercharger. Such special supercharging provisions generally require a considerable amount of space both for themselves and for the intercoolers and duct work. Since the compartment behind the engine is already crowded, it is difficult if not impossible to find the space for this purpose.

The exhaust system, too, must receive its share of attention, as must the various accessories and the manual and automatic controls. Special equipment may be required. A fire-extinguishing system for the engine compartment, which is exposed to many fire hazards, or an engine-driven supercharger for the cabin of a high-altitude airplane are examples of this sort.

Figure 158 gives a diagram for a typical power-plant installation such as might be used in a 20-passenger twin-engine air liner. Careful study of its details will give a good idea of the general layout commonly employed for air-cooled radial engines. The installation is not radially symmetrical because of the carburetor air scoop at the top and the oil cooler at the bottom. The dotted lines drawn through the oil cooler show the contour of the side cowling and flaps. Figure 159 gives a layout for a fire wall for an installation of this sort and shows how the various lines may be grouped for accessibility.

Figure 160 shows the installation of the liquid-cooled V-12 Allison engine in Curtiss P-40 fighters. Note the amount of plumbing, the long carburetor air duct between the cylinder heads, and the oil and coolant radiators slung beneath the engine.

Figure 161 shows a four-cylinder opposed engine installed in a light plane. Note the provision for cabin and carburetor air heat incorporated in the exhaust manifold.

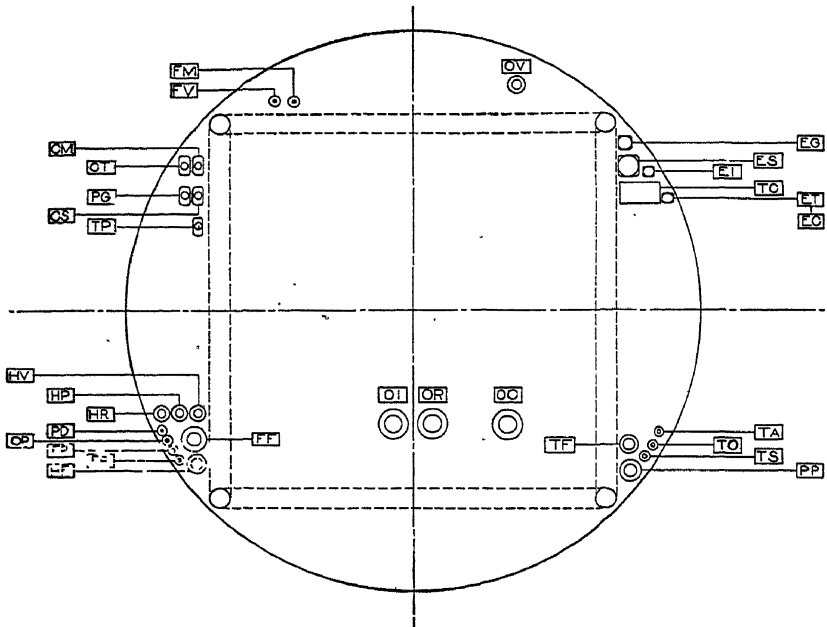

ENGINE OPERATING CONTROLS

(CT) Throttle
(CM) Mixture
(CS) Supercharger Speed

TEMPERATURE CONTROLS

F) Cowl Flaps
P) Carburetor Preheat
S) Oil Shutter

ELECTRICAL CONNECTIONS

(EG) Generator
(ES) Starter
(EI) Ignition
(ET) Tachometer
(EC) Prop. Feathering Cut-Out

PROPELLER

G) Governor Control
P) Feathering Pressure Oil
D) Deicing Fluid

FUEL SYSTEM

FF) Main Feed
FP) Fuel Pressure
FR) Primer
FV) Vapor Return
FM) Manifold Pressure

OIL SYSTEM

OI) Oil to Engine
OR) Oil Return from Engine
OC) Oil Return from Cooler
OP) Oil Pressure
OV) Oil Tank Vent

ACCESSORY PIPING

(HV) Vacuum Pump
(HP) Hydraulic Pressure
(HR) Hydraulic Return
(HE) Fire Extinguisher

THERMOMETERS

TC) Cylinder Temperatures
TO) Oil in Temperature
TA) Carburetor Air Temperature

FIG. 159.—Layout of the fire wall for an installation such as that in Fig. 158. (Pratt & Whitney Aircraft.)

Engine Installation Weight.—Table VII indicates the distribution of weight in the installation of an engine of from 1,000 to 2,000 hp. The values in the table are for conventional install-

ations. In special cases the range may be wider than that given. The dry weight of the engine and the weight of

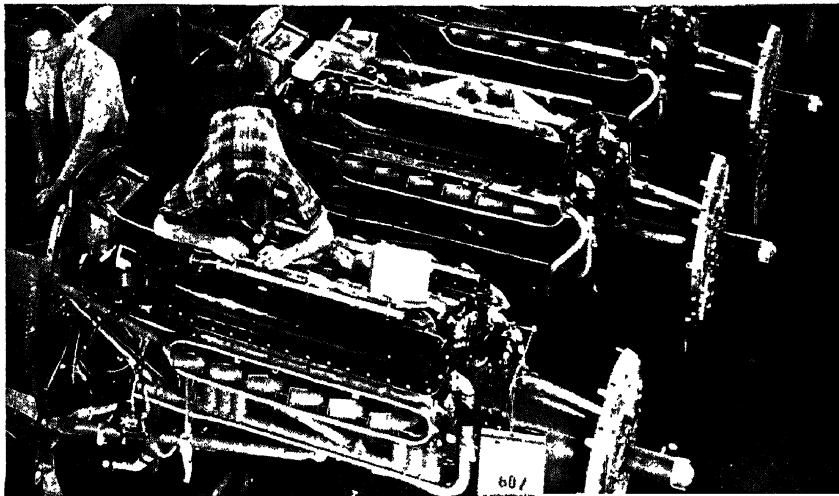

Fig. 160.—Allison engines being installed in Curtiss P-40 fighters. (Lord Manufacturing Co.)

TABLE VII.—WEIGHT OF ENGINE INSTALLATION COMPONENTS*
(Pounds per take-off horsepower)

Engine.....	1.000-1.300
Propeller and controls.....	0.300-0.350
Engine mount.....	0.045-0.080
Cowling.....	0.063-0.100
Exhaust system.....	0.027-0.087
Carburetor air scoop.....	0.015-0.025
Oil system (empty).....	0.040-0.060
Fuel system (except tanks).....	0.020-0.040
Starter.....	0.020-0.045
Generator.....	0.025-0.035
Miscellaneous.....	0.015-0.030
Radiators and coolant for liquid-cooled engines.	0.200-0.280
Weight increase for multistage over single-stage supercharger installations:	
Two-stage engine-driven supercharger with inter- or aftercoolers.....	0.150-0.250
Exhaust turbosupercharger with ducts, intercoolers, and controls.....	0.300-0.400

* This table was based on similar tables given in references 2 and 3 but has been modified somewhat in the light of more recent information.

the cowling of liquid-cooled engines tend toward the lower limit given, thus partially offsetting the weight of the radiators and

coolant. The weight of the fuel tanks varies widely with the type of airplane, and so it is not included.

Accessibility Requirements.—Overhead costs on large commercial airplanes are high. Every minute required for servicing results in charges, not only for labor and hangar space, but for overhead on the airplane as well. In military work, the cost of the time spent in servicing an airplane may sometimes be incal-

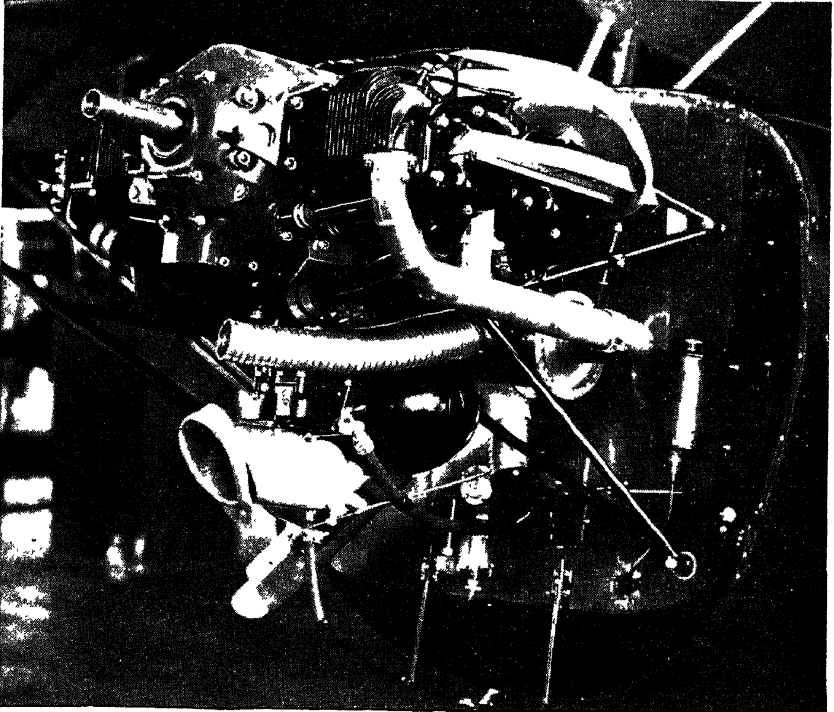

FIG. 161.—Light-plane engine installation. (*Piper Aircraft Corp.*)

culable. For small private airplanes, hangar space and labor may be the only charges; but before we can have the vast numbers of private airplanes sometimes predicted, the cost of servicing and maintaining those planes must be reduced far below that for existing equipment. No matter what the type, therefore, one of the most important considerations from the standpoint of the purchaser of a new airplane is the time required for its maintenance. The accessibility provided by the airplane designer is one of the most important factors determining this

time. The maintenance work on the airplane power plant might be roughly classified in three groups: (1) routine check work and adjustment, (2) removal and replacement of some one element, and (3) removal and replacement of the engine itself. Every possible operation coming under each of these headings should be foreseen and planned for in detail before the airplane goes into production.

There are many items requiring checking and adjustment at regular intervals of approximately 50 hr of operation. The controls must be checked for travel and lost motion, the engine-mounting bolts for tightness, the exhaust system for tightness and freedom from cracks, the oil and fuel lines for leaks, etc. The spark plugs must be removed and replaced with a new or reconditioned set. The oil sump should be drained and the drainings inspected for chips, which denote a failed part. The oil- and fuel-pressure relief valves, which are located on their respective pumps, may require readjustment. Other work of a similar character may be necessary at less frequent intervals. Strainers in the fuel system and the oil strainers in the engine must be cleaned. The valve clearances in the engine require adjustment. The exact list of work to be done varies somewhat with the engine and the type of installation, but the bulk of it can be anticipated by the designer and good accessibility provided.

Other items requiring attention or replacement include accessories and engine cylinders. A cylinder and piston, for example, may become lightly scored under abnormal conditions. It is often desirable to remove and replace a cylinder in such cases without disturbing the rest of the engine. Similarly, valve trouble may require removal of a cylinder to permit servicing the valves. Magneto breaker points, coils, or condensers may be suspected of causing trouble and require checking and/or replacement of either the part or the whole magneto. Similarly, the starter, generator, fuel pump, vacuum pump, or other accessories may require replacement. Sufficient clearance must be provided to permit a mechanic to remove the attaching nuts and safety devices as well as to make it possible to extricate the part or accessory from the crowded compartment.

Removal of the engine itself from the airplane for overhaul may be greatly simplified by grouping the various lines neatly together and terminating them at easily reached junction boxes

on the fire wall. Fittings on the control rods or cables may be designed for quick disconnection. The layout of the various elements should be made so that a maximum number of men can work on the installation or removal of the engine at the same time without interfering with one another. Due consideration must

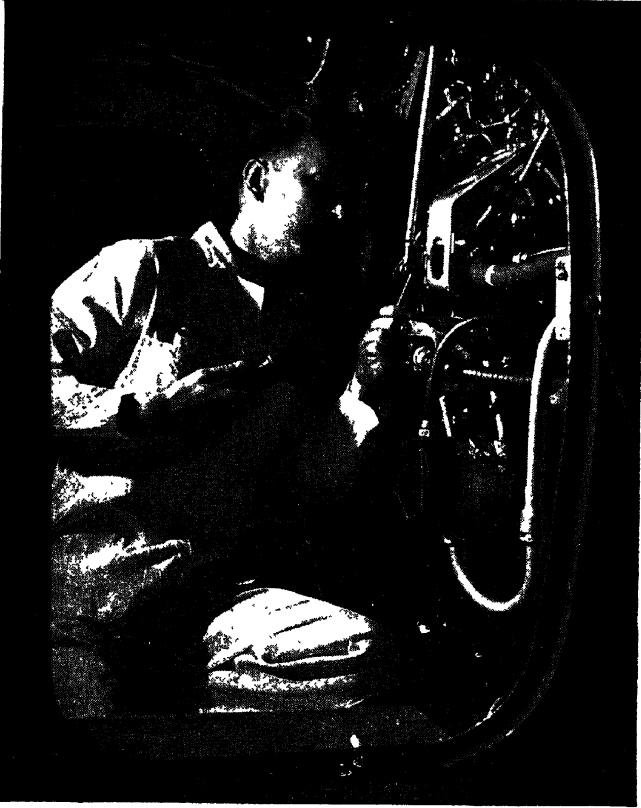

FIG. 162.—Nacelle of a large flying boat showing a mechanic working at the rear of the engine. (*Pan American Airways.*)

be given to the exact means to be employed in lifting the engine into and out of the airplane so that nothing will interfere with this operation.

Accessibility of the power plant in flight was not a factor until the advent of large airplanes of more than 60,000 lb gross weight. It also happens that in such airplanes the height of the engine nacelles above the ground or water level makes access from outside difficult without special platforms and other facilities

generally available only at a major overhaul base. Both for emergency work on the ground and for servicing in flight, it is desirable to design the installation in a large airplane to permit work to be carried out on it by a man approaching through the wing. Thus a door, or at least a manhole, is required in the fire wall. To make all lines and equipment easy to reach and work on from a point in the center of the fire wall requires an entirely different



FIG. 163.—Power plant of the Douglas B-19. (*Douglas Aircraft Co., Inc.*)

layout from that needed for an installation to be serviced from the outside alone.

Figure 162 shows a mechanic working in the nacelle of a Pan American Airways Clipper. He has entered the nacelle through a catwalk in the wing and has removed a panel in the fire wall to enable him to work directly on the lines and controls connected to the engine. The starter, generator, and magnetos can be seen at the right. Figure 163 shows an installation for a large Army bomber, the B-19. It employs a type of engine mount that supports the engine from the cylinder heads, leaving the space behind the engine free of structural members. Such an installa-

tion can be designed to make it possible for a mechanic to remove and replace the rear spark plugs in flight, thus taking care of the item most likely to cause engine trouble on flights lasting more than 40 hr.

Power-plant Units.—The high cost of the engineering and testing necessary to work out a satisfactory engine installation led to the development of "power-plant units." Details of engine cooling, accessory location, the exhaust system, etc., may be worked out for one unit, which may then be installed against a standard bulkhead or fire wall in any of several similar types of plane, thus reducing both initial and maintenance costs. The idea was developed in England and in Germany just prior to the Second World War. In both cases, the engine manufacturer took the responsibility for the design and construction of the complete installation and supplied the same unit to several different airplane manufacturers.

Figure 156 shows a power-plant unit built in Germany for the Junkers JU90 transport. Other airplanes were also designed to use this complete unit. Note that the oil tank and all accessories are included. In this particular case the compartment behind the engine is badly crowded and would be difficult to service. The orderly arrangement of lines and wires indicated in Fig. 159 would be much better.

American practice has been for the airplane manufacturer to assume the responsibility for the design and construction of the power-plant installation, the engine manufacturer serving as a consultant. Since requirements vary so widely among airplanes, no standard unit for several airplane types has made its appearance.

The use of a power-plant unit that can be disconnected at the fire wall is advantageous from other standpoints. The hours required for the installation or removal of the large quantity of special equipment immediately behind the engine need not tie up the whole airplane—the installation can be disconnected at the fire wall, removed from the airplane, and worked on in the more convenient quarters of the engine overhaul shop. The number of lines, screws, bolts, nuts, fasteners, etc., to be installed or removed while the engine is in the airplane is greatly reduced. The time required to make such an installation may be as low as 20 min as compared with about 10 hr if the equipment is installed on the engine after its installation in the airplane. Figure

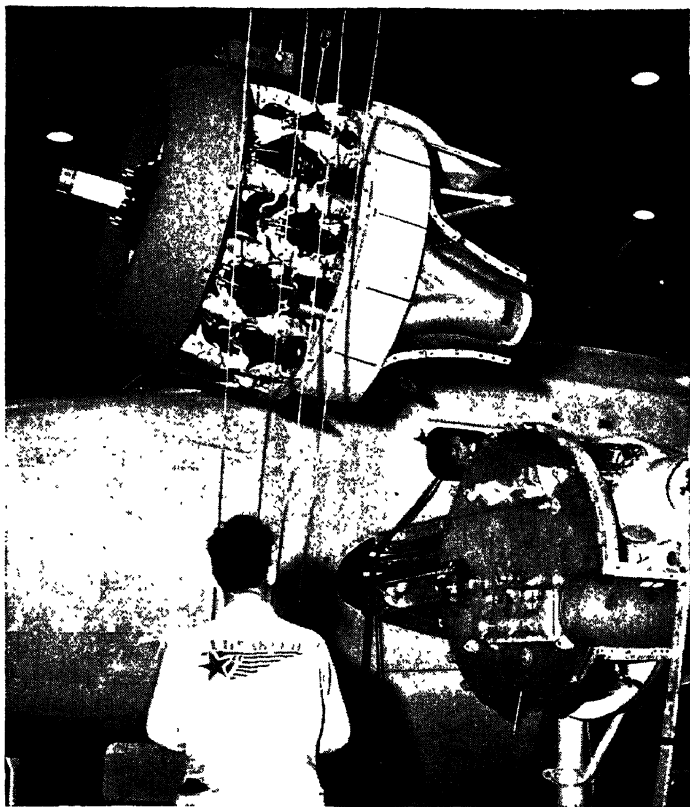

FIG. 164.—Power-plant unit being moved into position for installation in a twin-engine bomber. (Lockheed Aircraft Corp.)



FIG. 165.—Bell Airacobra fighter. (Bell Aircraft Corp.)

164 shows a power-plant unit of this type being installed in an airplane.

Submerged Installations.—The lightness and simplicity inherent in the familiar closely coupled tractor engine-propeller arrangement has caused development work to be concentrated in that direction. Few design engineers cared to risk trying a design that involved not only a long, relatively flexible, and vibration-susceptible shaft between the engine and propeller, but a whole new set of cooling problems if an air-cooled engine were used. Until recently, the time and expense almost certainly necessary could not be justified by possible improvements in airplane performance. The Bell Airacuda and Airacobra (see Fig. 165) clearly demonstrated the practicability of remote propeller drives. Use of the Allison engine made the problem of cooling no greater than in any conventional liquid-cooled engine installation. Figure 166 shows the propeller extension-shaft arrangement used in the Bell Airacobra. This makes possible the use of a tricycle landing gear, a 37-mm cannon firing through the propeller, an aerodynamically ideal fuselage shape, and a forward location of the pilot, giving excellent visibility.

Figure 167 shows another development, the Northrup Flying Wing, in which two air-cooled four-cylinder opposed engines are completely enclosed in the wing and pusher propellers driven through extension shafts. Note the engine cooling-air inlet openings in the leading edge of the wing. This is one example which shows that an air-cooled engine can be cooled successfully even when completely submerged. The cooling-air-duct problem is somewhat greater than for a liquid-cooled engine, but the reduction in drag in high-speed airplanes may make the extra complication well worth while.

Summary.—The engine installation evidently presents many interrelated problems, each of which is complex yet none of which may be completely separated from the others. Insofar as possible, in the following chapters the installation is discussed according to its various components, each group of problems being studied individually in a separate chapter.

Development of engine installations has been so rapid and the diversity of available equipment so great that an effort has been made to present only the elements of the problems involved. Detail design data should be obtained from the manufacturers of the engines and equipment contemplated, from the power-plant

sections of Army or Navy handbooks for airplane designers, from the civil air regulations, or from N.A.C.A. reports. The

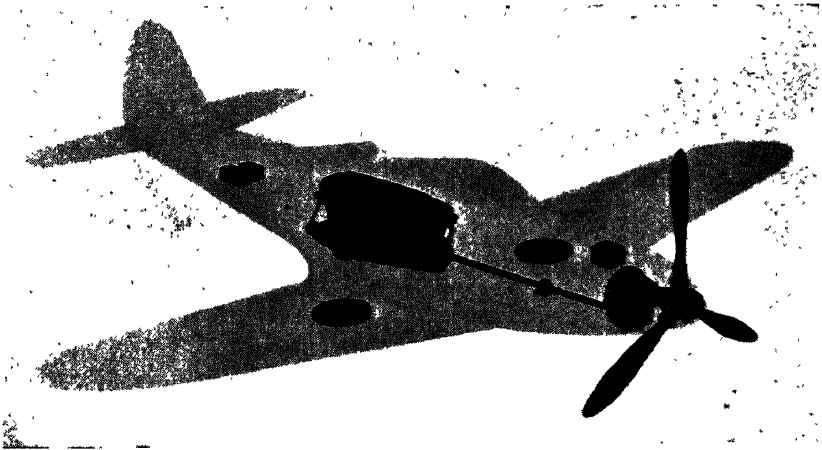

FIG. 166.—Shadowgraph showing the engine, shaft, and reduction-gear arrangement used in the Airacobra. (*Bell Aircraft Corp.*)

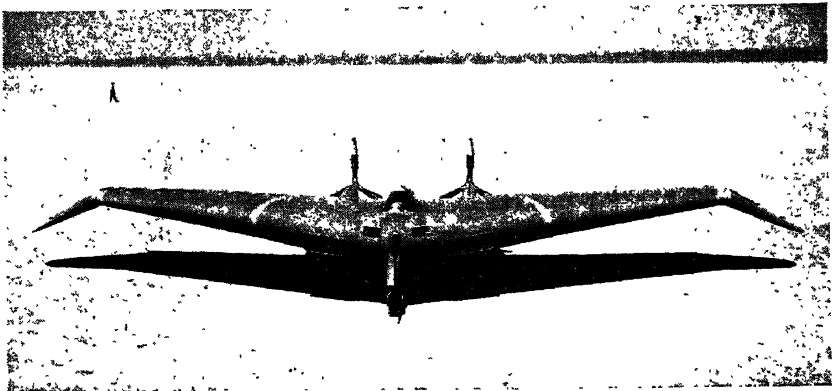

FIG. 167.—Northrup Flying Wing. (*Northrup Aircraft, Inc.*)

chapters that follow give the essentials of the background on which such specific design information is based.

References

1. SULZMAN, E. C.: Aircraft Engine Installations, *Aeronautical Eng. Rev.*, September, 1942.
2. LEE, J. G.: Air-cooled vs. Liquid-cooled Aircraft, *Jour. I.A.S.*, vol. 8, No. 6, April, 1941.
3. ANDERSON, P. A.: Air-cooled Radial Aircraft Engine Installations, *S.A.E. Trans.*, vol. 31, 1936.

CHAPTER XVI

ENGINE MOUNTS

The engine mount should support and accurately locate the engine and yet should not permit the transmission of vibration from it to the rest of the airplane. It should permit easy accessibility to all points likely to require attention in service and should make removal of the engine itself as simple a job as possible. A considerable amount of thought must precede the layout if these requirements are to be satisfied.

TYPES OF MOUNT

Attachment.—Most engines are supported from lugs, or bosses, made integral with the crankcase. In radial engines, the lugs are made integral with the intake pipe bosses in the supercharger housing, giving a circular set of attaching points just behind the cylinders (see Fig. 10, page 20). In liquid-cooled V- and in air-cooled in-line engines, there are ordinarily four points of attachment, one on either side at both the front and the rear. Figure 160 shows an installation of this type. The opposed-cylinder-type engines used so widely in light planes may provide points of attachment at the sides of the crankcase, or they may have four lugs disposed around the rear of the engine in a vertical plane as in radial engines (see Fig. 161).

It has been demonstrated that radial engines may be mounted by using the rocker boxes as points of attachment. Although one might at first think that the cylinder barrels are not strong enough to permit this, it may be recalled that one of the conventional ways of lifting an engine in an overhaul shop is by the rocker bolts of two cylinders. From the standpoint of strength, the rocker boxes are one of the best parts of the engine to use as mount attaching points. The fact that they have not been more extensively used for mounting purposes is probably due to accessibility difficulties.

Construction.—Mounts for radial engines have generally been of the form shown in Fig. 168. This type was naturally suited

to rectangular fuselages of welded-steel tubing and has persisted in airplanes of monocoque construction. In-line engines have generally used truss-type mounts such as that in Fig. 169. These require a sway brace to prevent lateral motion in maneuvers. In either case, careful consideration should be given to accessibility and service problems. The diameter of the mount ring, for example, should be great enough to permit installation or

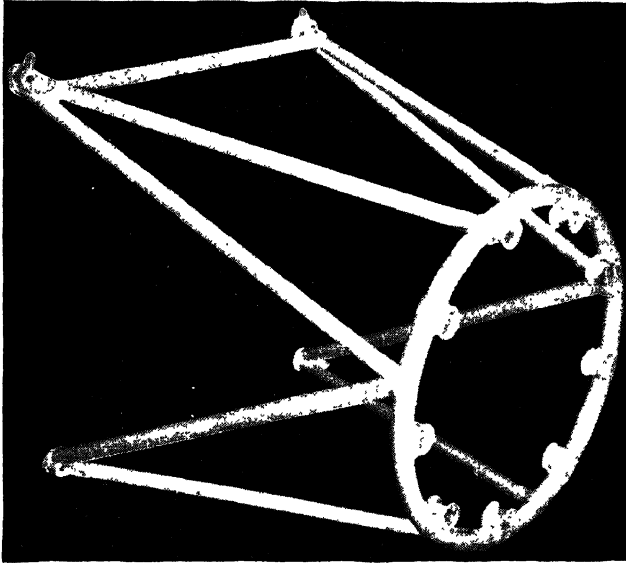

FIG. 168.—Welded-steel-tubing mount for a radial engine. (*Aero Digest.*)

removal of the engine with all accessories in place, including any which might be used even though not specifically planned for.

Fabrication.—American practice has favored the welded-steel-tube engine mount because of its lightness, simplicity, and relatively low cost, coupled with the high fatigue resistance of steel so important in highly stressed parts subject to engine vibration. Almost all engine installations, from the smallest to the largest, have used this type. One especially good feature is that fitting the airplane with any one of several different but similar engines presents no great problem—the same attaching points on the fire wall may be used and a different engine mount made up with little added expense.

Actual fabrication of the mount is complicated by the shrinkage and warpage accompanying the welding process. This may be reduced somewhat by using electric-arc instead of torch welding if the tube wall thickness is sufficiently great. Most manufacturers use S.A.E. X4130 chrome-molybdenum steel tubing. By preheating before welding, a fairly uniform normalized structure will be obtained in the weld and in its vicinity so that heat-

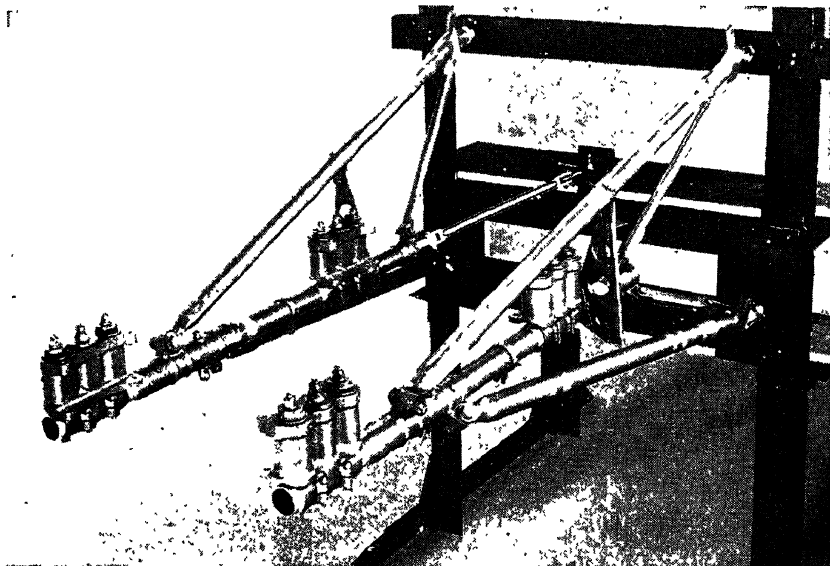

FIG. 169.—Engine mount for a Curtiss P-40 fighter showing tubular rubber mounting bushings. (*Lord Manufacturing Co.*)

treating and further warping can be avoided. Careful design will reduce the number of distances that must be held to close tolerances. Many of these may be given considerably wider limits by machining after the assembly has been welded. The center-to-center distance between the holes for the mounting bolts at the fire wall, for example, can be held very closely by drilling those holes in the mount after welding.

The economics of high production suggests that perhaps some better or less expensive mount might be devised. That shown in Fig. 169 is made of steel tubing with steel fittings instead of welds used to join the tubes together. A fitting is simply slipped over a tube and clamped in place by tightening bolts along the split side, the relatively large area of contact giv-

ing adequate strength. The fittings may be made by subcontractors, permitting quick and accurate assembly of the complete mount near the final assembly line of the aircraft plant, with no need for further machining. A somewhat similar mount might be made with the fittings and tubes brazed together as one assembly.

In-line engine installations in Germany have commonly made use of steel forgings as engine bearers, with a few links to provide the rest of the support required and to prevent sway.

ENGINE SUSPENSION AND VIBRATION ISOLATION

Airplane Vibration.—Vibration-exciting forces originating in the engine and propeller may be transmitted to the rest of the airplane. The nervous systems of the airplane passengers and crew generally require a much lower vibration level than would be permitted by the allowable stresses in the airplane structure. Since human psychological reaction to vibration depends primarily on absolute amplitude, the problem becomes more acute as airplane size is increased because the amplitude of vibration of a wing, for example, must be much smaller relative to its span to keep the absolute amplitude below that physiologically allowable. Use of all-metal airplanes with their low damping characteristics has also aggravated conditions.

Vibration Isolation.—A number of methods of vibration isolation of the power plant from the airplane structure have been used. Some have been rudimentary, involving no more than a washer of rubber or brake lining between the engine and the supporting structure. Such attempts to absorb vibration through the damping characteristics of some material have not been effective for the smaller engines and have been practically worthless for the larger engines because of the large amount of energy that must be absorbed.

The familiar notion of "floating power" as used in the automobile is much more promising for vibration isolation. In the six-cylinder automobile engine the only serious vibration-exciting force is torsional. By supporting the engine so that it is fairly free to vibrate torsionally, the engine exciting forces tend only to displace the mass of the engine, not the whole automobile. The resulting amplitudes of motion at the engine may be higher than with a rigid mounting, but very little vibration reaches the rest

of the automobile. Further, the maximum stresses induced in all associated parts are, in general, lower. This method of vibration isolation depends upon the characteristic of vibrating systems discussed in the chapter on Vibration (page 197) and shown graphically in Fig. 97, *viz.*: The amplitude of motion of an elastically suspended mass acted on by an exciting force will be quite small if the natural frequency of the system is made considerably less than the frequency of the exciting force.

Isolation of Torsional Vibration.—Since some of the largest vibration-exciting forces from the engine are torsional, it has

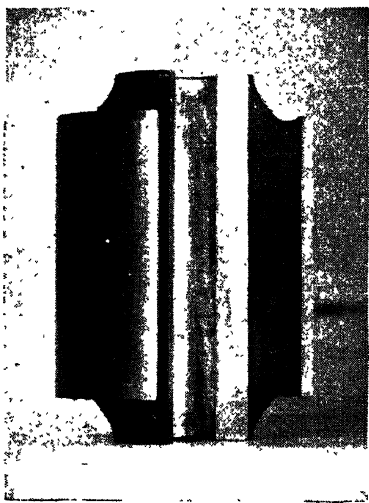

FIG. 170.—Sectioned tubular rubber engine-mount bushing. (Lord Manufacturing Co.)

been desirable to incorporate in the mount a vibration-isolation arrangement comparable with the floating-power mounting of automobile engines. This may be done by mounting the engine so that it has enough torsional freedom to give a natural frequency in torsion that is below the frequency range of the engine exciting forces. One method is to make use of rubber bushings around the bolts attaching a radial engine to the engine-mount ring. By using bushings placed in holes that are elongated in a direction tangent to the mounting circle as shown in Fig. 168, torsional flexibility is obtained without permitting appreciable

“sag” or “droop” of the engine itself due to radial or axial deflections in the bushings. An even better arrangement is to use tubular rubber bushings in which steel sleeves are vulcanized to the inner and outer surfaces of a rubber tube (see Fig. 170). Since rubber is much more flexible in shear than in tension or compression, such bushings can be made to give springs that are much more flexible under axial than radial loads. Rubber springs of this sort can be mounted with their axes tangent to the engine mounting circle, the outer steel sleeve being rigidly attached to the engine and the inner steel sleeve attached to the engine mount to give torsional freedom. By properly selecting the dimensions

of these rubber springs, the natural frequency of the power plant so mounted may be placed below the normal idling rpm. thus effectively isolating engine torsional vibration from the airplane in the cruising- and high-power range.

In-line engines may also be provided with a rubber spring suspension to prevent transmission of torsional vibration to the airplane structure. This can be done as shown in Fig. 169. Groups of three bushings each are used at each of the four mounting points to develop the necessary strength in this case.

Isolation of Unbalanced Forces and Couples.—The inertia unbalance of the radial engine, together with propeller unbalance, sets up large vibration-exciting forces which are not isolated by the methods mentioned above for torsional vibration. In fact, unless care is taken in the design, a suspension intended to give only torsional-vibration isolation may be flexible enough in other directions to give natural frequencies for other modes of motion that lie in the operating range. Aside from flexibility in the rubber bushings, the steel engine mount itself is flexible. As a result, a radial engine and its mount may vibrate in much the same fashion as the cantilever beam mentioned in the chapter on Vibration (page 173). Bending in either a vertical or a horizontal plane may be possible. First mode bending (see Fig. 94*a*) would be excited by the unbalanced forces, while second and higher bending modes would be caused by the unbalanced couples. If the mount of a radial engine is symmetrical, its natural frequency will be the same in both vertical and horizontal planes; but if it is not symmetrical, large amplitudes of vibration will occur over the entire frequency range between the natural frequency in the vertical direction and that in the horizontal direction. Thus a symmetrical mount is much better for radial engines because it limits the natural frequency to a narrow range.

To provide complete vibration isolation, it is necessary to place the natural frequency of horizontal and vertical translational engine motion, and of angular engine motion about all axes, below the normal frequency range of the exciting forces. Ordinary spring-suspension systems designed to accomplish this give deflections that are too large, allowing the engine to droop and sag as much as several inches from the mean position. A method of engine suspension has been devised that places the

natural frequency of all modes of motion below the frequency range of the exciting forces at idling speeds.¹ It depends on

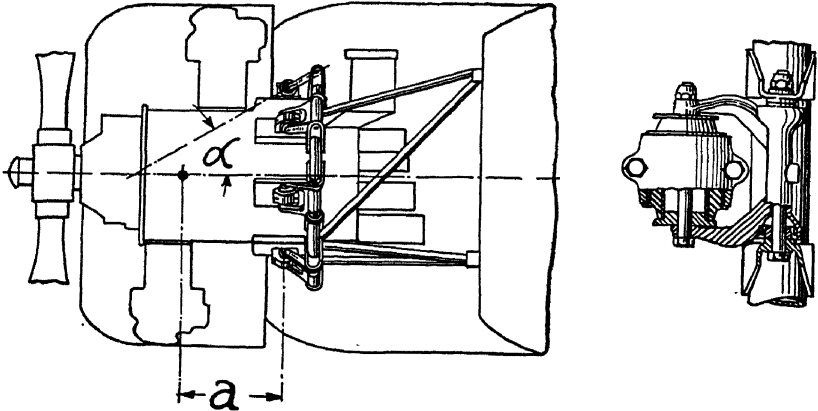

FIG. 171.—Diagram showing the forces acting in an engine mount of the dynamic suspension type. (*Browne, S.A.E. Trans., vol. 34, 1939.*)

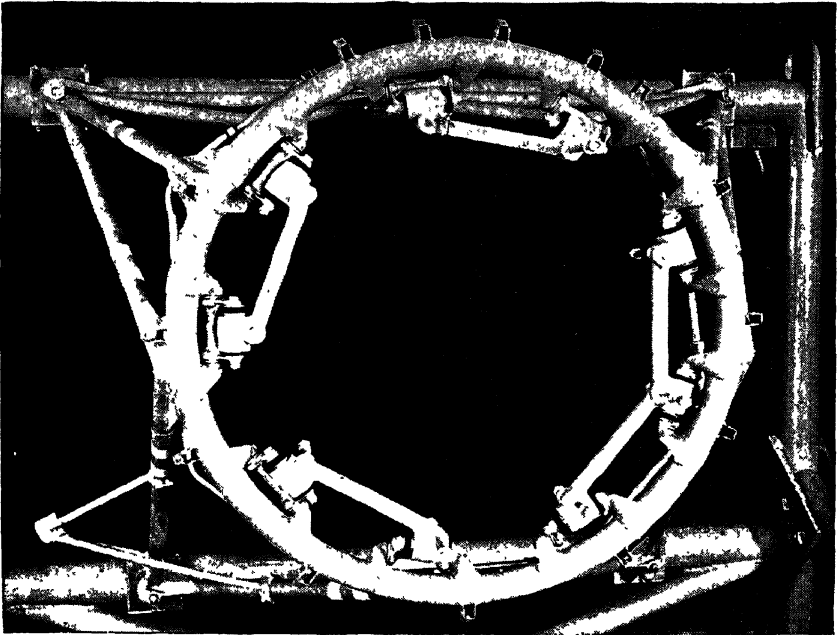

FIG. 172.—Front view of a dynamic-suspension-type mount for a Boeing B-17 bomber. (*Lord Manufacturing Co.*)

the use of springs that are stiff in one direction and flexible in the other two. Figure 171 is a diagram of an engine mounted

on these springs. Each spring is mounted with its stiff axis making the angle α with the axis of the engine crankshaft. The springs are distributed symmetrically around the engine mounting ring so that their stiff axes form a cone, the apex of which lies on the crankshaft axis. The distance between the apex of this cone and the center of gravity of the engine-propeller combination is made such that deflection in the mount-

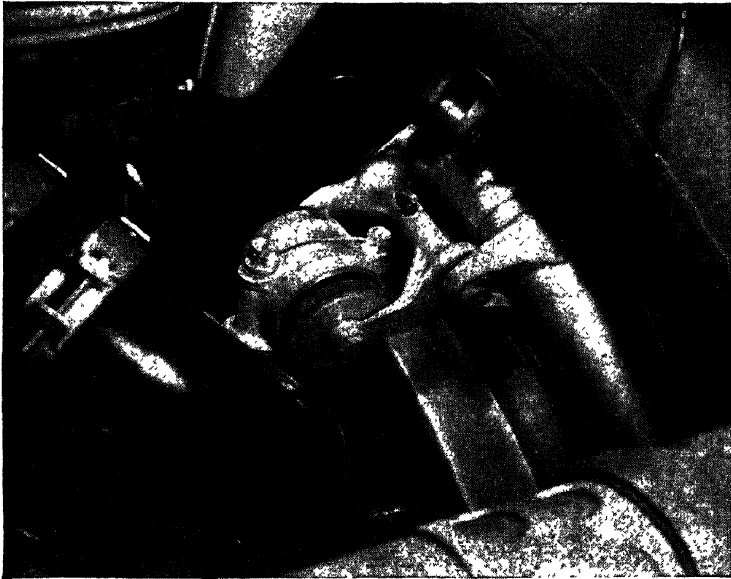

FIG. 173.—Detail view of the hinge and tubular rubber-bushing arrangement used in a mount similar to that in Fig. 172. (*Lord Manufacturing Co.*)

ing springs due to radial forces acting at the center of gravity causes no angular deflection of the engine. This may be visualized by considering a force acting vertically downward at the center of gravity in Fig. 171. It must be transmitted to the apex of the cone, where it sets up both a downward-acting force and a clockwise moment. The force is carried by the springs, which deflect. This deflection tends to cause the front of the propeller shaft to droop downward; *i.e.*, it tends to cause rotation in a counterclockwise direction. This rotation is opposed by the clockwise moment acting at the apex of the cone. Thus droop is prevented, and the sag kept to a minimum.

Two versions of this method of vibration isolation have been developed. Figure 172 shows a “dynamic-suspension-”

type mount. This makes use of tangential rubber bushings such as that shown in Fig. 170, mounted in links shown in detail in Fig. 173. Each hinged link is free to rotate about an axis parallel to that of the rubber bushing it supports. The transmission of forces from the engine to the mount is geometrically complex, but the net effect is to fix the engine's fore-and-aft position closely and yet permit the proper amount of torsional, angular, and translational flexibility.

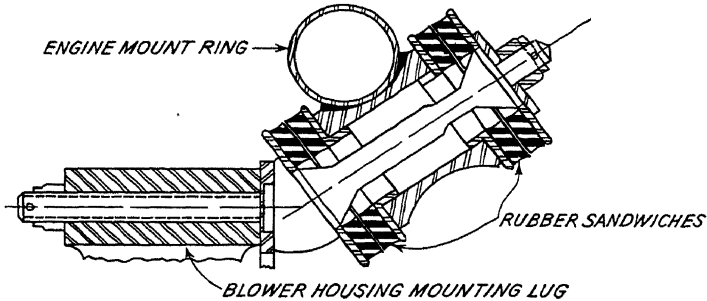

FIG. 174.—Rubber sandwich-type of vibration-isolating rubber engine-mount bushing. (Goodyear Tire & Rubber Co., Inc.)

Figure 174 shows a detail of a mounting device making use of rubber in shear to oppose motion in all directions in which flexibility is required. One such device is placed at each of the mounting points on the engine, the arrangement being as shown at the right of the figure. The rubber is stressed in shear by torque forces. Fore-and-aft forces are restrained in compression. Pitch and yaw are restrained mainly in shear and partly by tension and compression.

References

1. TAYLOR, E. S., and K. A. BROWNE: *Vibration Isolation of Aircraft Power Plants*, *I.A.S. Jour.*, vol. 6, No. 2, December, 1938.
2. BROWNE, K. A.: *Dynamic Suspension—A Method of Aircraft Engine Mounting*, *S.A.E. Trans.*, vol. 34, 1939.

CHAPTER XVII

COWLING OF AIR-COOLED ENGINES

The cowling of the aircraft engine is important both from the standpoint of its effect on airplane drag and from the standpoint of its effect on engine operation, including cooling, maintenance, and other problems. In the liquid-cooled engine, its principal function is to provide a streamlined fairing to minimize drag. It also serves to house the engine and protect it somewhat from the weather. In the air-cooled engine, the cowl has the additional function of directing and, in part, controlling engine cooling air flow.

DRAG CONSIDERATIONS

The N.A.C.A. Cowling.—At first, radial engines were not cowed because it was thought that the engine, already insufficiently cooled, would run too hot. The N.A.C.A. laboratory at Langley Field conducted extensive tests on a cowling designed to allow the air stream to flow smoothly around the nose of the fuselage. This greatly reduced the drag of the airplane. At the same time, the cowling was designed to trap air from the propeller slip stream so that a region of high pressure was built up in front of the cylinders. Baffles placed between and partly behind the cylinders (see Fig. 86, page 162) permitted a relatively small amount of cooling air to pass, but the baffles could be so arranged that this cooling air was employed very efficiently—every bit that did flow was forced to pass within an eighth of an inch or less of the hot cooling-fin surfaces. As a result, although a much smaller volume of cooling air flowed over the engine, better cooling could be obtained. This N.A.C.A.-type cowling was eminently satisfactory for all types of service for the decade prior to the Second World War. Radial engines developed for use with this cowling have been relatively large in diameter and provided a relatively short distance between the rear of the propeller and the cylinders. This gave the familiar blunt-nosed installation in current use (see Fig. 175). The engine cooling obtained with the

large frontal opening has been good and the drag not excessive. As speeds were increased progressively from about 150 mph, refinements in cowl design made it possible to keep the engine-installation drag within reasonable limits without materially changing the appearance of the cowling. Above about 200 mph, only about 10 per cent of the air flowing toward such a cowl flows through it—the rest must flow radially outward and around the outer edge.

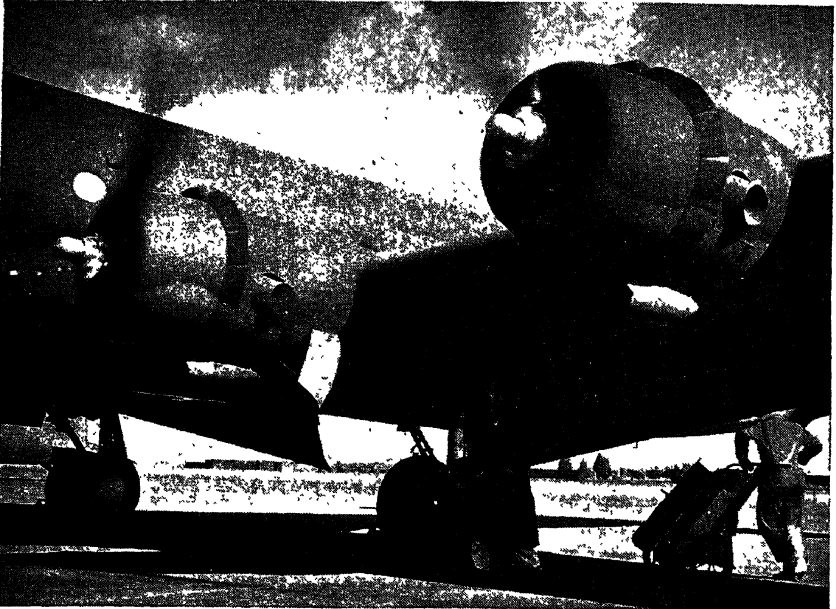

FIG. 175.—Port nacelles of the Douglas C-54. (Douglas Aircraft Co., Inc.)

Figure 176 shows a typical case as analyzed by a smoke-flow study.¹ At speeds above 350 mph, the sharp bends in the streamlines result in high local velocities, which are responsible for compressibility effects similar to those found with airfoils. Of course, when a “compressibility burble” is formed at the rim of a cowling, the drag is greatly increased. But, before considering detailed refinements in the N.A.C.A. cowling, let us first examine the nature of the drag due to the engine and cowling.

Form Drag.—That part of the total drag of the airplane chargeable to the size and external shape of the cowling is called the “external,” or “form,” drag to distinguish it from the “internal,” or “cooling,” drag. The latter is caused by the air flow

through the cowling and over the engine in an air-cooled engine installation and may be quite large. The amount of form drag with which an engine and cowling should be charged depends on several considerations besides the frontal area of the engine. The form drag may be taken as the increase in drag of the complete installation over that of a perfectly streamlined body of the same diameter; or it may be considered as the increase in drag of the complete installation over that of a perfectly streamlined body of a smaller diameter. The latter comparison may be valid in the case of a small pursuit ship in which the ideal maxi-

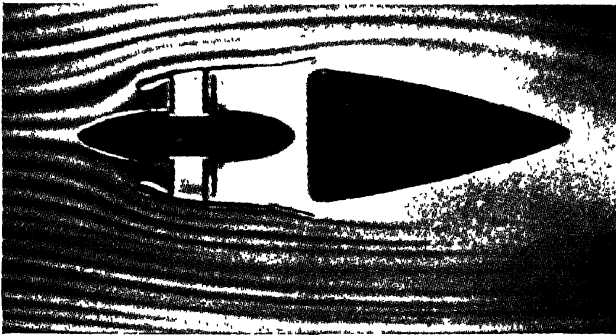

FIG. 176.—Smoke flow around and through the nacelle of a radial aircraft engine with the cowl flaps wide open. (*Griswold, S.A.E. Trans., vol. 36, 1941.*)

imum fuselage cross section is just large enough to contain the pilot. Any increase in drag due to an increase in fuselage cross-sectional area caused by the engine might be charged to the engine. This increase is not so large as one might expect, however, as the drag of a body like a fuselage increases much less rapidly than its frontal area, being more nearly proportional to the total surface area of fuselage and wing. It has been pointed out that, although the largest American radial engines require about double the minimum fuselage size needed to house a pilot, this doubling of the fuselage diameter may cause a fuselage-drag increase of less than 50 per cent. Since much equipment, etc., must be carried in modern airplanes, space is at a premium. It may well be worth while—in fact, it is often essential—to increase the fuselage diameter to provide extra space, in which case the engine installation should not be held responsible for the increase in fuselage cross-sectional area. The same conditions apply to engine nacelles in the wings, though to a lesser extent.

The drag increase due to the blunt shape of the conventional N.A.C.A. cowling over a streamlined body of the same cross-

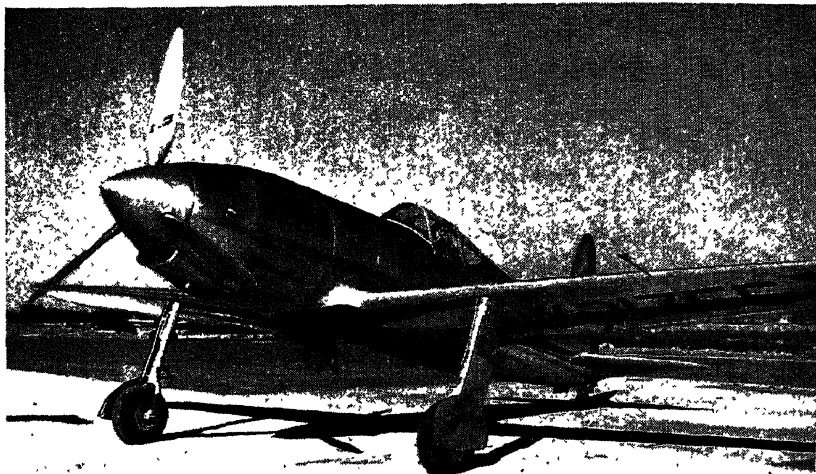

FIG. 177.—Vultee Vanguard pursuit powered with a 1,200-hp twin-row radial engine having an extended nose section to eliminate the usual blunt-nosed cowling. (*Vultee Aircraft, Inc.*)

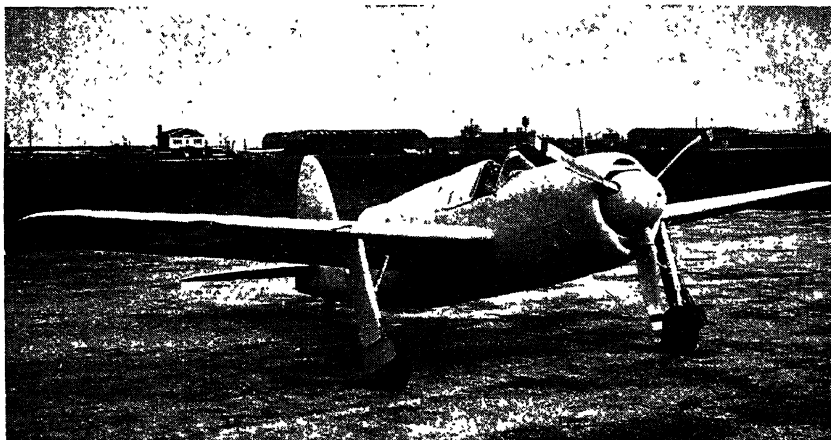

FIG. 178.—Brewster dive bomber powered with a 1,700-hp twin-row radial engine. (*Brewster Aeronautical Corp.*)

sectional area runs on the order of only 35 per cent below 350 mph. For higher air speeds a blunt shape may induce compressibility and it is advisable to make use of a better aero-

dynamic shape. One way of doing this is to place an "extended nose" on the engine and carry the cowling farther forward. Figure 177 shows one such arrangement tested experimentally. As will be shown later, the ground cooling characteristics of such an arrangement are likely to be poor. Further, the weight increase due to the extended nose section would be on the order of 50 lb. Large spinners seem to offer a lighter solution. They serve to streamline the shanks of the propeller blades as well—an important advantage because the blade sections are poor close to the hub and are responsible for a considerable amount of drag at high speeds if left exposed. Figure 178 shows an installation making use of a large spinner to maintain streamline flow free of serious compressibility effects at air speeds considerably above 350 mph.

Cooling Drag.—Forcing air over the cooling fins and through the engine baffle passages results in a power loss referred to as "cooling drag," for it increases the drag of the airplane. Quantitatively, this is given by

$$\text{Cooling hp} = \frac{\Delta p \times Q}{33,000} \quad (34)$$

where Δp = baffle pressure drop, lb per sq ft.

Q = volume of air flowing, cu ft per min.

However, for a particular engine-baffle combination,

$$\Delta p = KQ^2$$

Hence,

$$\text{Cooling hp} =$$

Thus it is evident that the cooling horsepower loss increases very rapidly as the volume of cooling air supplied is increased. A certain amount of this power loss is unavoidable. Depending on the engine power output, the minimum amount for safe operation will be from 2 to about 6 per cent of the brake horsepower.

Figure 179 shows curves of cooling air flow and cooling horsepower loss plotted against baffle pressure drop for an engine of about 1,000 hp. These show that, if the baffle pressure drop can be kept low, the cooling horsepower loss will not be serious. Further, it is theoretically possible to regain much of this loss at flight speeds above 200 mph by utilizing the heat energy added

to the cooling air as it passes over the engine. Although design of the engine installation for conversion of this energy into thrust horsepower is rather difficult, recent experimental work has demonstrated the possibilities (see Chap. XVIII, page 330, for a more complete discussion of the problem).

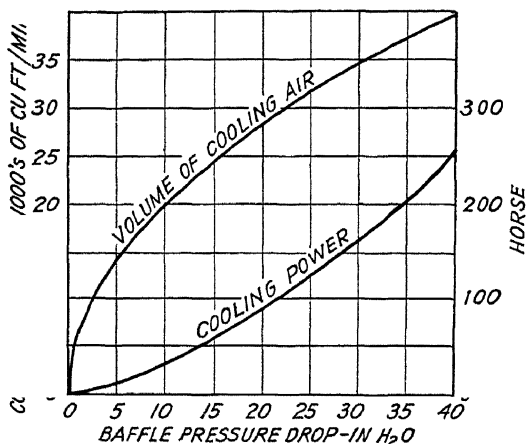

FIG. 179.—Relation between cooling air flow and baffle pressure drop. (Replot of data given by Campbell, *S.A.E. Trans.*, vol. 33, 1938.)

COOLING CONSIDERATIONS

Cooling Required.—Since the volume of air flow and its corresponding baffle pressure drop required for cooling depend on so many variables, it is necessary to consider each phase of actual engine operation separately. Ground cooling at idling and the low powers required for taxiing must be adequate. Such operation would require baffle pressure drops of 1 or 2 in. H₂O, depending on the amount of power and the length of time that power would be used.

Take-off power is the greatest that the engine can be called on to produce, but it is obtained with extremely rich mixtures. Further, the heat capacity of the cylinder heads can be counted on to absorb some heat so that, if the cylinder-head temperatures run 250°F at the beginning of the take-off, an appreciable length of time is required to raise their temperature to the maximum allowable, say 450°F. As a result, it is generally possible to operate an engine for 1 or 2 min at take-off power with a baffle pressure drop of only about 4 in. H₂O. Operation for a longer period of time might result in overheating, with consequent

cylinder scoring. It is also easy to see why careless ground operation of the engine resulting in head temperatures of, say, 425°F. might be responsible for engine overheating on an otherwise normal take-off. Figure 180 shows a typical curve of head temperature vs. time at take-off power for conditions of constant power, fuel-air ratio, and baffle pressure drop. The engine, of course, had been given a normal warm up before the throttle was opened to the take-off position and the data for the curve were taken.

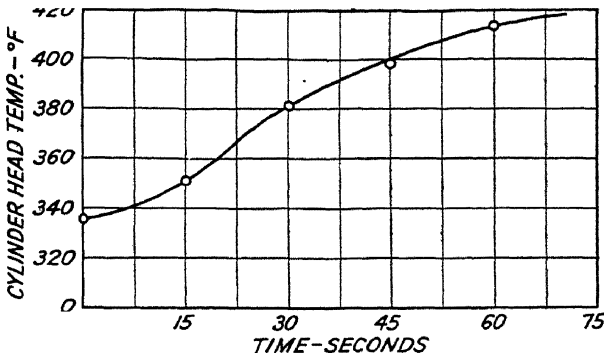

FIG. 180.—Cylinder-head temperature as a function of time at full throttle for a four-cylinder opposed air-cooled engine after a long idle. The engine was both loaded and cooled with a flight propeller. (*Daniel Guggenheim School of Aeronautics, New York University.*)

Climbing after the take-off may be carried out at rated power with mixtures somewhat leaner than those used for take-off. For such operation, minimum baffle pressure drops on the order of 6 in. H_2O are required to prevent overheating.

Cruising operation is ordinarily at 30 to 70 per cent of rated power. However, since lean mixtures are generally used, somewhat higher baffle pressure drops are required in spite of the lower power outputs. Further, to prolong the life of engine parts, to lower maintenance costs, and to assist in obtaining the lowest possible specific fuel consumption, the cylinder-head temperatures at cruising are ordinarily kept about 100 to 150° below the maximum allowable. This, of course, means a considerable increase in the baffle pressure drop required (see Fig. 89).

A good picture of the cooling required by current air-cooled engines is given by Fig. 181. As pointed out above, rated

and take-off powers require less cooling, both because of richer mixtures and higher allowable head temperatures. Different models and makes of engines vary somewhat in the specific values of their cooling requirements, but Fig. 181 may be taken as typical.

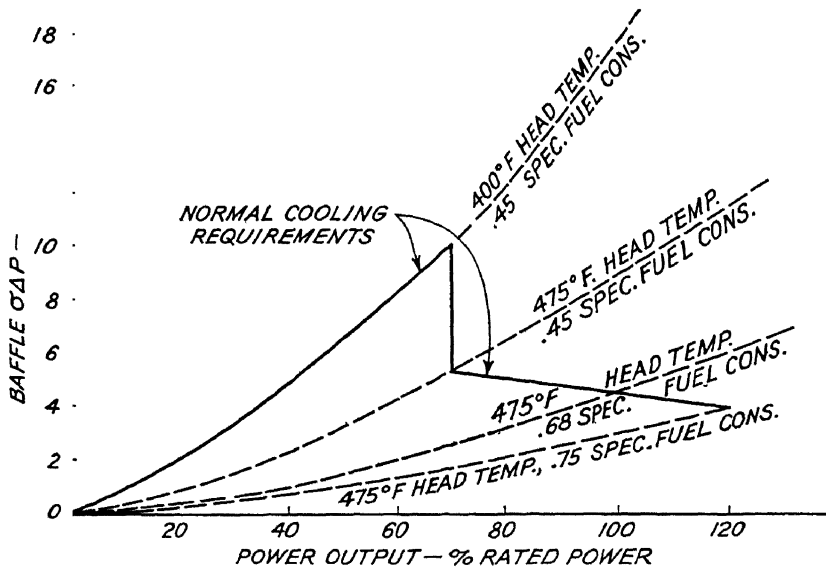

FIG. 181.—Baffle pressure drop required to cool a typical air-cooled engine as a function of power output along a propeller-load curve. Values were computed on the basis of Eq. (27).

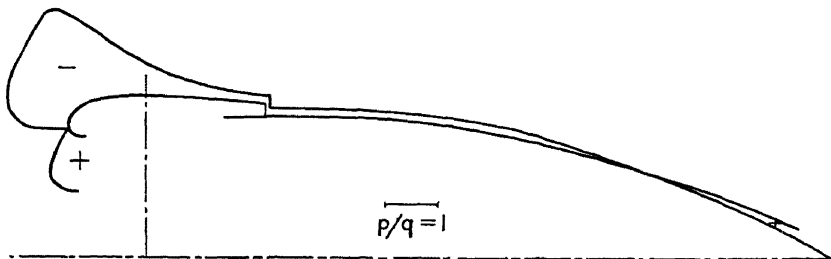

FIG. 182.—Static-pressure distribution around the nacelle of a radial engine. (Theodorsen, Brevoort, and Stickle, *N.A.C.A. Tech. Rept.*, 593, 1937.)

Cooling Available.—The principal factor in determining the baffle pressure drop available is the forward velocity of flight. The dynamic pressure set up by this forward velocity is converted into static pressure at the front of the cowling. Figure 182 shows the pressure distribution around a typical cowling and

nacelle.³ The region of positive pressure extends over the opening at the front of the cowling, while a negative-pressure region extends from just behind the front edge rearward over the skirt.

Owing to the negative pressure existing at the exit slot, the total baffle pressure drop available may be a little greater than the dynamic pressure given by the velocity of flight. However, other factors remaining constant, the baffle pressure drop available is proportional to the dynamic pressure. Figure 183 shows the dynamic pressure plotted against air speed for both sea-level and altitude conditions.

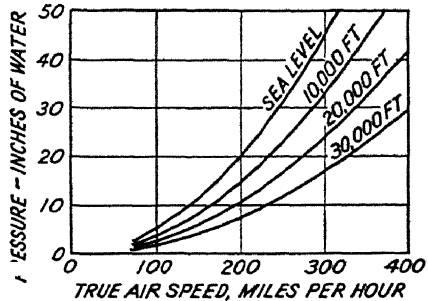

FIG. 183.—Dynamic pressure of flight. (Kittler, *S.A.E. Trans.*, vol. 49, 1941.)

The propeller slip stream has little effect except on the ground and during the take-off run. Under these conditions, however, it is the principal cooling agent. Figure 184 shows the cooling-

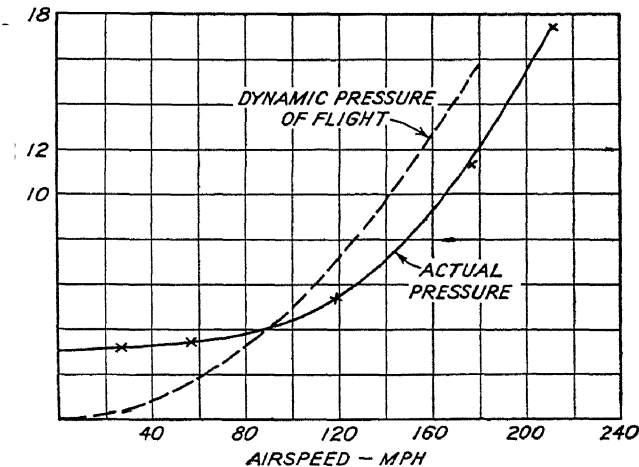

FIG. 184.—Actual baffle pressure drop available. (Replot of data given in Theodorsen, Brevoort, and Stickle, *N.A.C.A. Tech. Rept.* 593, 1937.)

air static pressure built up ahead of the baffles, plotted against air speed for an installation run at constant take-off rpm and constant propeller-blade angle.⁴ On the same sheet is plotted the dynamic pressure of flight, *i.e.*, the pressure theoretically

available. The difference between the two curves at the lower end is due to the propeller slip stream while that toward the upper end is due to the fact that the cooling air passes over the cylinders at an appreciable velocity and thus not all the dynamic pressure can be converted into static pressure. Increase in propeller-blade angle causes an increase in the static pressure at the cowl inlet up to the point where the blades stall. Increasing

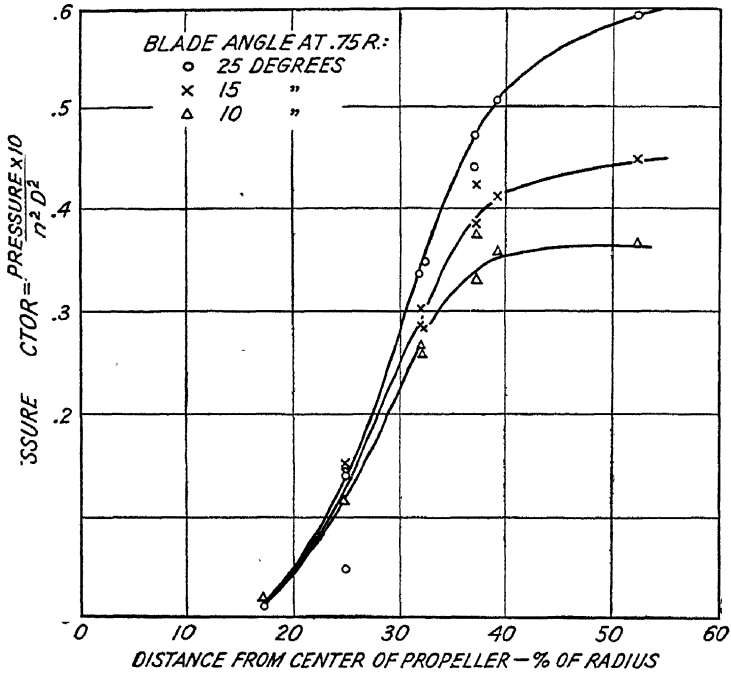

FIG. 185.—Radial distribution across the front of the cowl of the pressure available for ground cooling. (Stickley and Joyner, N.A.C.A. Tech. Note 673, 1938.)

the propeller rpm causes an approximately proportional increase in available baffle pressure drop for zero forward velocities of the airplane. The propeller-fan action depends to a large extent on the propeller-blade section close to the hub.

N.A.C.A. Technical Note 673 gives the results of a ground-cooling investigation that clearly demonstrated the ineffectiveness of the round blade shanks close to the propeller hub.⁵ Figure 185, taken from this report, shows the radial pressure distribution across the front of the cowl obtained by blocking it off into annular rings. Smoke-flow studies showed that the

air might actually flow forward at the hub, bleeding off the pressure that would otherwise be built up by the blade sections farther out from the hub. It was found that simply placing a round disk behind the ineffective portions of the blades to block off this forward "leakage" considerably increased the available pressure. As a result of this investigation, a number of installations were fitted with similar disks, and the ground cooling was

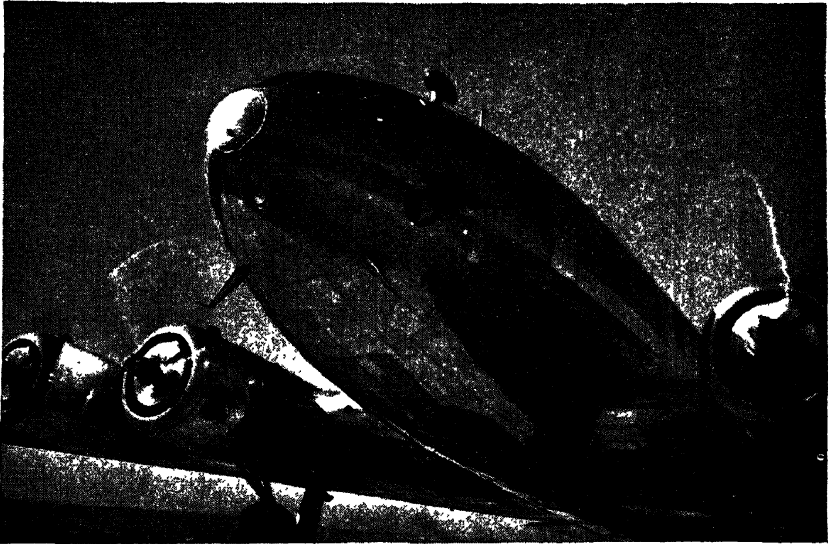

FIG. 186.—Boeing model 307 showing disks behind the propeller hub to improve ground cooling. (*Wright Aeronautical Corp.*)

found to have been improved. Figure 186 shows one such installation. Of course, the same result can be obtained with a spinner. Thus the large spinner shown in Fig. 178 actually improves ground cooling by blocking off a large area at the center of the cowl opening.

Since the large propellers now in use do not have effective blade sections even within 18 in. of the center of the hub, some have been fitted with "cooling cuffs" to extend the effective blade section right into the spinner and thus improve ground cooling. These cuffs are simply short airfoils made of sheet metal and light castings or a plastic. The outer end has the same airfoil section as the propeller blade at that point. The cuff carries that airfoil section in nearly to the hub. Note that the propeller blade in Fig. 246 has been fitted with these cooling cuffs.

They often make just the difference between satisfactory and unsatisfactory ground cooling. Specifications ordinarily require that the installation be capable of operation for extended periods without overheating when stationary on the ground with the engine operating at 40 per cent of rated rpm on a ground propeller-load curve. Cooling cuffs have little effect on cooling in flight.

Another factor having an effect on ground cooling is the distance between the trailing edge of the propeller blades and the cowling. If this distance is large, leakage of air from the high-

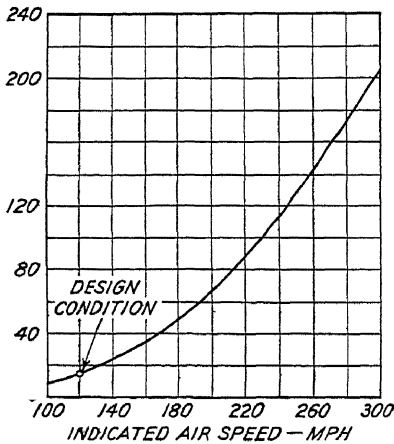

FIG. 187.—Effect of airplane speed on the power expended in forcing the cooling air through nacelle with a fixed exit-slot cowling. (Wright Aeronautical Corp.)

pressure region in the front of the cowling out over the rim will be excessive. Clearance considerations demand that the distance be on the order of 1 in. for the high-pitch, or feathered, position of the propeller blades in order to make certain that interference will not occur. Unnecessarily large clearances, however, should be avoided.

Cowl Flaps.—Consideration of the baffle pressure drop available as compared with that required for various conditions shows that there is scarcely enough cooling available for ground operation, take-off, and climb, but that there is usually much more than enough for cruising, high-speed flight, and, especially, descent at low power from high altitudes. Overcooling in the latter case would almost certainly result in fouled spark plugs. A sudden demand for power in an emergency would then result in misfiring and possibly complete “cutting out” of the engine. An even more important consideration is cooling drag. Figure 187 shows cooling drag plotted against indicated air speed for an installation designed for adequate cooling of a 1,000-hp engine in a rated-power climb at 120 mph. According to this, if we assume a propeller efficiency of 80 per cent, at 300 mph 25 per cent of the engine power, a prohibitive amount, would go into cooling. To control the cooling air flow and avoid both wasted power and

overcooling of the engine, cowl exit flaps are ordinarily provided (see Fig. 175). They may be adjusted to maintain the correct baffle pressure drop across the engine. The pressure drop across a well-designed exit slot results in an acceleration of the air flowing through it, with a consequent jet propulsion effect so that the pressure energy of the air ahead of the exit slot is converted into velocity energy, giving a thrust effect with negligible losses. In fact, the heat energy added to the air by the engine may cause sufficient expansion to give an appreciable gain in thrust (see the theoretical discussion, page 329).

By deflecting the propeller slip stream, the flaps also form a region of low pressure behind them when opened. This may almost double the available baffle pressure drop for ground and take-off operation. However, the flaps greatly increase the airplane drag. Cases have been reported in which they have actually doubled the drag of the fuselage. Figure 176 gives some idea of the extent to which they disturb the air flow. Note the turbulence and flow separation behind the flaps. If they are used over the top of a wing nacelle, the flow over the wing may be seriously affected and the lift reduced considerably. As a result, many recent installations have made use of flaps at only the lower part of the cowling, all the cooling air being discharged in that region (see Fig. 188). In this case, the cooling air is discharged through the rectangular flap at the front of the landing-wheel well. Unfortunately, such installations are likely to give poor cooling of the upper cylinders.

The serious drag of cowl exit flaps in the open position has been recognized for some time, but they have been retained because of their mechanical simplicity. Other aerodynamically superior arrangements are not difficult to devise; but they are usually too complicated, or they do not give the improvement in ground cooling obtainable with exit flaps.

Exit-slot Area Required.—Actual exit-slot and flap design is greatly complicated by aerodynamic considerations. However, the amount of effective exit area required for any flight speed may be calculated on the basis of conventional fluid-flow formulas. The specific method used depends on the available data. A method developed by the N.A.C.A. makes use of the notion of "engine conductivity" K , which is simply the ratio of the effective baffle passage area to the frontal area of the engine.⁶ Simi-

larly, the conductivity of the exit slot K_2 is the ratio of the effective slot area to the frontal area of the engine. Since the

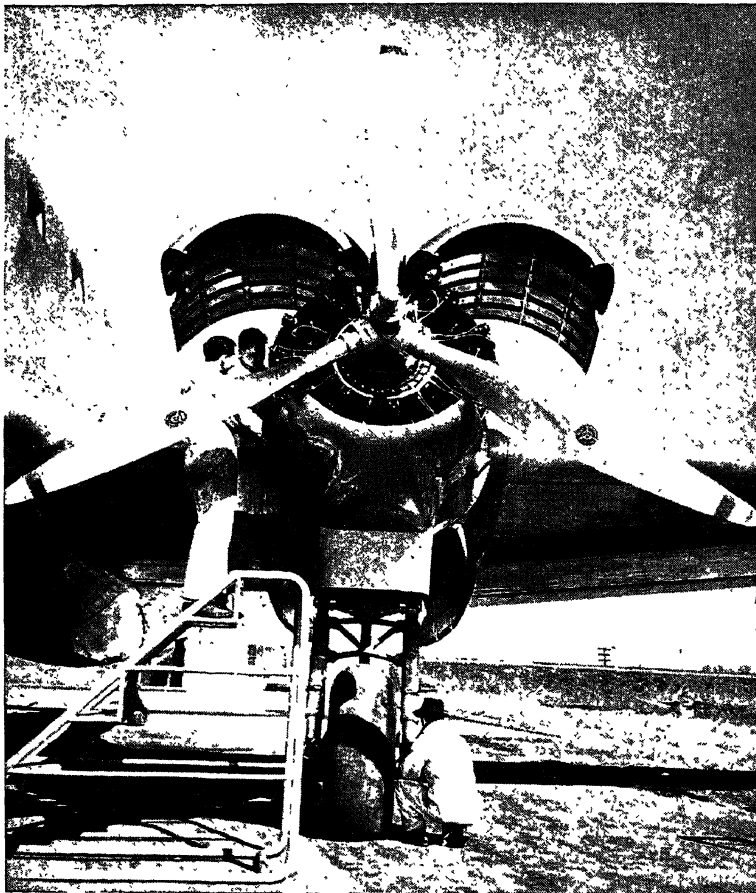

FIG. 188.—Curtiss CW-20, showing the cowl panels raised to give ready access to the engine and accessories. (*Wright Aeronautical Corp.*)

volume of air flowing through the two restrictions is the same, we may write

$$\text{Volume flowing} = FK \sqrt{2gH_1} = FK_2 \sqrt{2gH_2}$$

and

$$\begin{aligned} \Delta p &\sim H_1 \\ q - \Delta p &\sim H_2 \end{aligned}$$

where F = engine frontal area.

H_1 = drop in static head across the baffles.

H_2 = drop in static head across the exit slot.

Δp = baffle pressure drop.

q = dynamic pressure of flight.

Substituting and rearranging,

$$\frac{K}{K_2} = \sqrt{\frac{1 - \frac{\Delta p}{q}}{\Delta p/q}} \quad (35)$$

From this it follows that, for a fixed exit-slot area and a given engine baffle system, the ratio of baffle pressure drop to dynamic pressure will remain constant for all flight speeds. The exit-slot area required may be determined easily from the above equation. The engine conductivity and frontal area are ordinarily given in the manufacturer's specification, together with the baffle pressure drop required for various power outputs. Thus the required exit-slot area is completely determined for any flight speed.

Nose Exit Slots.—There is a region of very low pressure just behind the front of the cowling, due to the high velocities around the relatively sharp curve at that point. Figure 182 shows the location and magnitude of this low-pressure region. Investigation has demonstrated the greatly increased baffle pressure drops available if the cooling-air exit slot is placed in this low-pressure region. In order to duct the air back to this exit slot, it is usually necessary to increase the cowling diameter to provide a passage between the outside circumference of the engine and the cowling. This may involve an increase in cowling diameter of as much as 5 in. Such an increase would ordinarily mean an increase in drag too great to justify the improvement in ground and take-off cooling.

If the air is passed back over the cylinder barrels and then forward over the heads to the nose exit slot, one has two restrictions in series impeding the cooling air flow, thus doubling the total pressure drop required for cooling. This method, although it avoids the use of a large cowl diameter, defeats its purpose by doubling the required pressure drop, with the net result that poorer rather than better cooling is obtained. Then, too, the baffle system required would be far too complicated.

In-Line Engines.—Not much has been written on the cowling and cooling of in-line air-cooled engines. In general, however, the same principles apply. The cooling air inlet should be located in a region of high pressure. Owing to the rotation of



FIG. 189.—Air-cooled in-line engine installation, showing the cooling air inlet at the front of the cowling. (*Ranger Aircraft Engines.*)

the propeller, this high-pressure region is displaced to one side of the nose of the cowling (see Fig. 189). This inlet delivers the air into a passage leading down one side of the engine from which it is directed across the cylinders by the baffles into a duct exhausting toward the rear of the airplane. Figure 190 shows

a typical duct and baffle arrangement. The horizontally opposed engine, so popular in the light-plane field, may be cooled in a similar fashion. These engines, if properly baffled, will cool adequately with baffle pressure drops of only 4.5 in. H₂O for continuous full-throttle operation at sea level.

Blower Cooling.—Occasionally the question arises as to the feasibility of cooling air-cooled radial engines of more than two rows or of cooling completely submerged installations. This

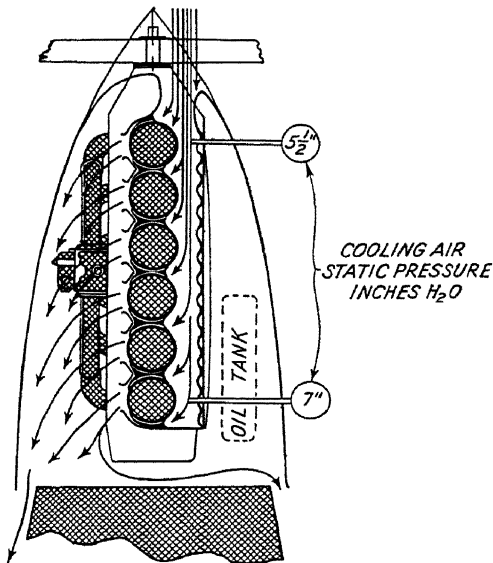

FIG. 190.—Air-cooled in-line engine baffle system. (*Ranger Aircraft Engines.*)

can be done by means of a blower. Power is expended to cool the engine in any case, and it might as well go directly into a blower designed specifically for that purpose. Most of the larger American tanks are powered with air-cooled engines cooled with blowers. Axial-flow fans suitable for this purpose have efficiencies of the order of 90 per cent and are relatively compact and quite light. The principal objection to their use is the added complication, which, if not absolutely required, had best be omitted, for our airplanes already have too many devices and mechanisms, all of which are potential sources of trouble. It seems likely that where the increase in weight, expense, and complication can be more than justified by improved perform-

ance, blower cooling will be used. A number of installations have already made their appearance.

INSTALLATION DETAILS

Cowl Attachment.—Various means of attaching cowls to the engine or airplane have been used. Early radial-engine cowls were of the “wrap-around” type in which the cowl ring was drawn up tightly over the tops of the rocker boxes in hoop fashion. This had a number of serious disadvantages, one being that the relatively high torsional inertia of the cowl caused considerable movement between the rocker-box covers on which it rested and the engine, resulting in rocker-box-cover gasket destruction and oil leaks. Further, cowls of the wrap-around type were not so positively located as is desirable. Most cowlings on radial engines today are attached to the cylinder heads by means of studs or lugs on the rocker boxes. Figure 158 shows a typical device. Whatever the method of attachment, it is desirable that the cowl be quickly and easily removable.

Engine vibration and movement, besides making the problem of cowl attachment difficult, is also responsible for chronic fatigue cracking of the sheet of which the cowl is formed. Stress concentrations around rivets are often the nuclei for fatigue cracks, which may spread at a relatively rapid rate. To reduce the amount of vibration transmitted to the cowling, small rubber bushings may be incorporated in the attaching bracket (see Fig. 158). This isolates the cowling from the engine in much the way that the engine mount may provide vibration isolation of the engine from the airplane structure.

The importance of engine and accessory accessibility for routine maintenance work cannot be overemphasized. One development giving exceptionally good accessibility is shown in Fig. 188. In this case, the cowling is supported from the airplane itself rather than the engine. This is particularly desirable in transport airplanes because torsional or other motion of the engine on flexible-type mounts is not transmitted to the cowling. Engine motion is quite large at idling speeds; and if the cowl moves with the engine, this may disturb the sense of security of passengers. Sealing the space between the rocker-box covers and the cowling is very important to reduce air leakage and con-

sequent internal drag. With this type of cowling, such sealing is a considerably greater problem.

Inner Cowls.—Inner cowls, or diaphragms, are provided to guide the air to the exit from the rear of the baffles and discharge it smoothly into the air stream with a minimum amount of disturbance to the latter (see Fig. 158). Such inner cowls often isolate the exhaust collector ring so that it does not impede or cause undue turbulence in the air flowing out through the exit slot. To minimize the fire hazard accompanying a leak in the exhaust manifold, they are ordinarily made of stainless steel. To provide cooling for the magnetos, small ducts, or *blast tubes*, may carry air from an opening in an intercylinder baffle to a connection on the magneto. Similar provision may be made to cool generators, machine guns, spark plugs, etc. Louvers or some other type of exit must be provided to afford some means by which this air may escape as well as to give some general ventilation in the compartment behind the engine.

Cowl-flap Controls.—Detail designs for mechanisms to control the cooling air flow depend on the airplane manufacturer. Systems generally provide a flap mechanism positively controlled from the cockpit and irreversible in action, *i.e.*, air forces on the flaps, etc., should not make them change their position. The actuating force may be supplied by the pilot or by hydraulic or electric mechanisms. Many training planes use a fixed cowl exit slot, complications being thus prevented. On engines of 1,000 hp and higher in larger airplanes, the returns entirely justify the added weight and complexity of the flaps. In some cases the cooling-air inlet passage has been made controllable and the exit opening left unimpeded (see Fig. 175). Control of the entrance area has the serious disadvantage of inherently higher drag due to the diffuser losses at the inlet. These are avoided with exit control.

References

1. GRISWOLD, R. W.: Visualized Aerodynamic Research, *S.A.E. Trans.*, vol. 36, 1941.
2. CAMPBELL, K.: Cylinder Cooling and Drag of Radial Engine Installations, *S.A.E. Trans.*, vol. 33, 1938.
3. THEODORSEN, T., M. J. BREVOORT, and G. W. STICKLE: Full Scale Tests of N.A.C.A. Cowlings, *N.A.C.A. Tech. Rept.* 592, 1937.

4. THEODORSEN, T., M. J. BREVOORT, and G. W. STICKLE: Cooling of Airplane Engines at Low Air Speeds, *N.A.C.A. Tech. Rept.* 593, 1937.
5. STICKLE, G. W., and V. T. JOYNER: The Pressure Available for Ground Cooling in Front of the Cowling of Air-cooled Airplane Engines, *N.A.C.A. Tech. Note* 673, 1938.
6. STICKLE, G. W.: Design of N.A.C.A. Cowlings for Radial Air-cooled Engines, *N.A.C.A. Tech. Rept.* 662, 1939.

CHAPTER XVIII

LIQUID-COOLANT SYSTEMS

The installation of a liquid-cooled engine presents a somewhat different set of problems from those of an air-cooled-engine installation. Since the engine and the heat-transfer surfaces for the cooling air are separated, greater flexibility in their location is possible. The most important consideration is the transmission of heat to the cooling air with a minimum power expenditure and a minimum amount of disturbance to the air stream. Other elements of the problem present certain difficulties that must be considered, but the limitations that they impose on airplane performance are not great.

THE COOLANT SYSTEM

Layout.—The layout and component parts of the coolant system for a Curtiss P-40 can be seen in Fig. 191. Ethylene glycol flows from the coolant pump up to and through the cylinder block, where it receives heat from the engine. It then flows out of the front of the cylinder head, down to and through the radiator, and back up to the coolant pump. Air or vapor that separates from the coolant as it leaves the cylinder head is carried back to the expansion tank. If the pressure in the expansion tank becomes sufficiently great, a relief valve will open to allow the air to escape. Glycol droplets in the vapor vented off are trapped and returned to the tank by the “sniffler valve.” The expansion tank is intended both to provide for the changes in coolant volume with changes in temperature and to constitute a small reservoir to make up losses due to evaporation or slight leaks. Thermostats are provided at the top of the radiators to by-pass coolant until it reaches the proper operating temperature. This permits a quick warm up.

The more important data on this coolant system are given in the tables in Fig. 191. Note that the total weight of coolant, radiators, and plumbing would run about 220 lb.

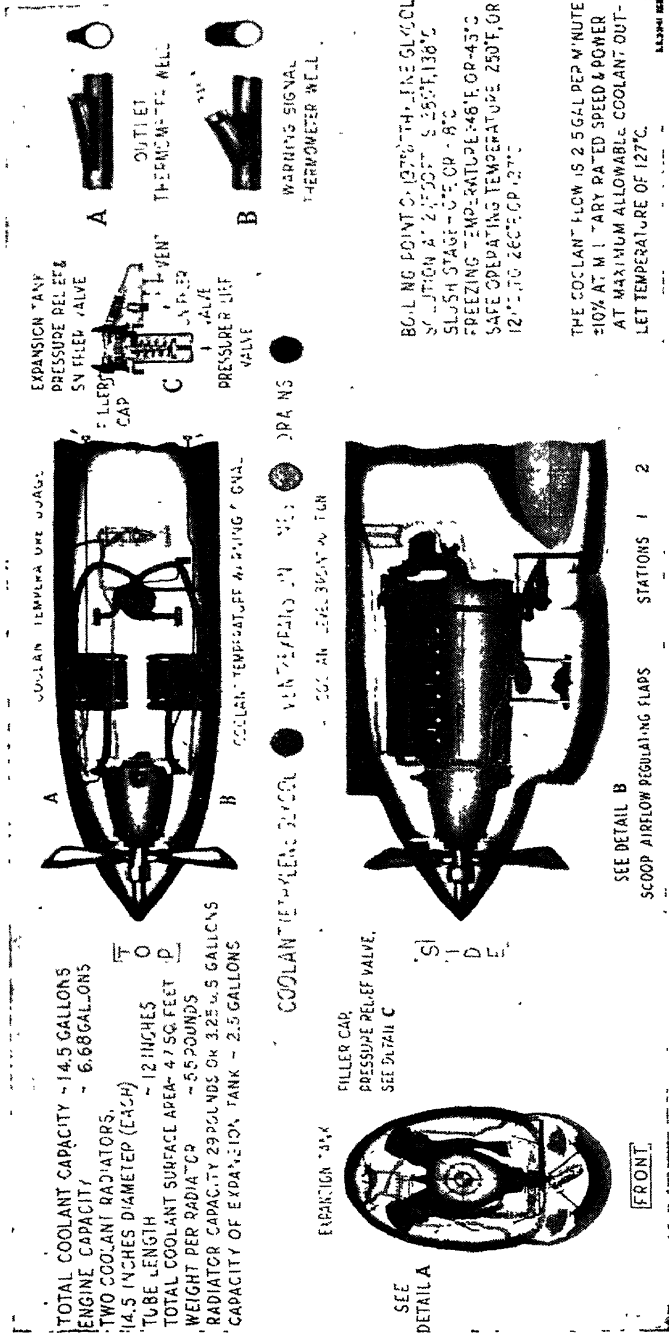

Fig. 191.—Typical coolant system for liquid-cooled engine. (Allison Division, General Motors Corp.)

Cooling Requirements.—As in the air-cooled engine, cooling during ground and take-off operation is difficult. Ground cooling is generally provided for by placing the radiator in the propeller slip stream, while the considerable heat capacity of the coolant itself may be depended upon to make up for any inadequacy of the radiator during the short time required for take-off. In a few cases, the high latent heat of vaporization of water has been used to provide cooling for take-off, as the amount of water evaporated in this manner would ordinarily be small. This is called *evaporative cooling*.

The critical design conditions are generally rated-power climb and high-speed flight. Cooling must be adequate in climb, and yet drag must be held to a minimum if the maximum possible top speed is to be attained. This problem is a vital one and deserves at least a brief discussion of the theory involved.

THEORY OF THE DUCTED RADIATOR

The Ducted Radiator.—Early liquid-cooled engine installations were of the simplest sort. They usually employed radiators suspended beneath the fuselage, completely exposed to the air stream. This resulted in considerable power losses due to three effects, *viz.*, (1) excessive turbulence and eddy losses in the air stream flowing around the radiator, (2) turbulence and eddy losses in the air stream passing through the radiator, and (3) high skin friction losses in the air stream passing over the heat-transfer surfaces. The first can be practically eliminated by enclosing the radiator in a suitable duct streamlined into the fuselage or wing. Properly proportioning the air passages will make the eddy losses in the duct negligible. The third item, the skin friction losses in the air stream passing over the heat-transfer surfaces, can be reduced by slowing the cooling air stream down in a diffuser passage ahead of the radiator core, passing it through the core at a low velocity, and then accelerating it through a converging passage and discharging it back into the air stream. Since the latter represents nearly all the loss that cannot be eliminated, an investigation of methods of reducing it to a minimum will be outlined below.

Some conception of the magnitude of the skin friction loss involved may be obtained by considering the fact that the heat-

transfer-surface area of the radiator for the coolant system shown in Fig. 191 amounted to about 30 per cent of the wetted area of the wing surface. Thus the skin frictional drag in the radiator cooling air stream would be 30 per cent of that of the wing if the cooling air velocity through the radiator were equal to the velocity of the airplane. This would be an intolerable amount. Since these power losses in the radiator core vary as the cube of the cooling air velocity, doubling the core area will give approximately one-eighth the cooling horsepower loss. Since this would double the radiator weight, a compromise between weight and power loss must be reached. The usual practice is to select a radiator core to give adequate cooling at rated power with a pressure drop across the core equal to that available at the best climbing speed, for, as in the air-cooled engine, this speed generally represents the condition most likely to give inadequate cooling. The lower cooling horsepower loss obtainable with a somewhat larger core will, however, often justify the weight and space penalties that it entails. Again, as in the air-cooled engine, the cooling air flow should be controlled by restricting the outlet. As greater pressures are built up in the radiator duct at the higher speeds, the exit opening may be closed off and the pressure drop there utilized to accelerate the air rearward. This gives a jet effect with little power loss other than the loss across the core, which, with the air flow held constant, becomes independent of airplane speed.

Potential Thrust from the Heated Duct Radiator.—Meredith¹ and more recently Rauscher and Phillips² have demonstrated that a considerable thrust is theoretically obtainable from a properly ducted radiator. These analyses are rather detailed and involved, but the basic idea and a fair quantitative approximation to the power available from this source may be included here. Since the analysis applies not only to coolant radiators, but to oil coolers, intercoolers, and air-cooled engines as well, it is quite important.

Consider Fig. 192, which shows air flowing through a heated duct radiator. If the radiator is cold, it can be seen from Bernoulli's theorem that the pressure loss across the core causes a decrease in the total pressure in the cooling air stream, resulting in a lower velocity at the exit than at the inlet. The difference in the momentum or, since the mass flow is constant, the differ-

ence in speed of the inlet and exit air stream is the factor responsible for the cooling drag, or cooling power loss.

Heat added to the air passing over a hot radiator results in an increase in its total energy. The heat is added at essentially constant pressure, causing an increase both in temperature and in volume. The larger volume results in higher exit velocities. If enough heat is added to the cooling air and the pressure drop across the radiator core is relatively small, as it is in high-speed flight when the flow is cut down, it is possible to obtain an

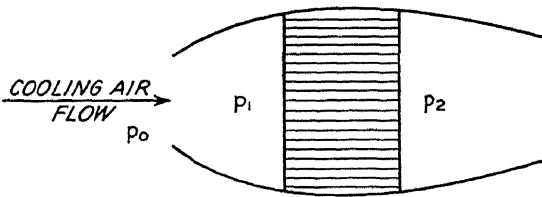

FIG 192.—Diagram for the cooling air flow through a ducted radiator.

increase in exit velocity over that at the inlet. This causes an increase in momentum and a thrust which acts on the airplane. The power obtainable from this thrust is equal to the product of the thrust force and the airplane speed. This factor may be quite large at the higher airplane air speeds.

The amount of power obtainable in this fashion can be determined most easily by subtracting the power lost in the core from the product of the energy added to the fluid and the thermodynamic efficiency of the resulting expansion. That is, the process of heating the air stream passing through the radiator core and expanding it through the exit opening to give a rearward-acting jet may be regarded as a regular thermodynamic work cycle.

The total pressure ahead of the core due to the dynamic pressure of flight would be

$$p_0 + \quad (36)$$

The pressure below the core is

$$p_2 = \frac{\rho V_0^2}{2} - \Delta p \quad (37)$$

- where p_0 = atmospheric pressure, lb per sq ft.
 - p_1 = pressure ahead of core, lb per sq ft.
 - p_2 = pressure behind core, lb per sq ft.
 - Δp = pressure drop across core, lb per sq ft.
 - V_0 = airplane velocity, fps.
 - V_c = air velocity into the core, fps.
 - hp_c = cooling power loss.
 - hp_g = net power gain.
 - A' = core area.
 - K = duct recovery or efficiency, usually about 0.90.
 - bhp = brake-horsepower output of the engine.
- The power loss in the core will be

$$hp_c = 550 \tag{38}$$

The efficiency of the thermodynamic process—*i.e.*, the addition of heat at constant pressure followed by an adiabatic expansion from the pressure behind the core into the main air stream—is given by

$$\eta = 1 - \left(\frac{p_2}{p_1} \right)^{\frac{\gamma-1}{\gamma}} \tag{39}$$

The exponent of the pressure ratio is 0.283 for air (see Chap. V, page 76). The heat rejection from the engine to the coolant generally runs from 45 to 50 per cent of the brake horsepower. With 50 per cent as an approximation, the useful work obtainable from the heat added to the cooling air becomes

$$\text{Useful work} = 0.5 \left[1 - \left(\frac{p_0}{p_2} \right)^0 \right] \tag{40}$$

The net power gain becomes

$$hp_g = 0.5 \left[1 - \left(\frac{p_0}{p_2} \right)^{0.283} \right] \text{bhp} - \tag{41}$$

Substituting values from Eqs. (37) and (38), this becomes

$$hp_g = 0.5 \left[1 - \left(\frac{p_0}{p_1 - \Delta p} \right)^{0.283} \right] \text{bhp} - \frac{\Delta p A' V_c}{550} \tag{42}$$

This equation may be used to investigate an actual case. Consider an airplane having a top speed of 400 mph (586 fps) at

an altitude of 20,000 ft where the atmospheric pressure is 13.75 in Hg (975 lb per sq ft) and the air density is 0.00127 slug per cu ft. Assume that the engine used develops 1,000 hp at that altitude and that the cross-sectional area of the radiator core is 2.3 sq ft. The pressure drop across the core would probably run about 10 in. H₂O (52 lb per sq ft), and the cooling air velocity into the core about 60 fps. Substituting these values, we obtain

$$= 0.5 \quad 1 - \quad 975 \quad \cdot 0.283 \quad 1,000$$

$$\frac{52 \times 2.3 \times 60}{550}$$

$$hp_g = 500 \left[1 - \left(\frac{975}{1,119} \right)^{0.283} \right] - 13$$

$$hp_g = 19 - 13 = 6$$

Note that, in general, an increase in airplane speed or a decrease in cooling-air pressure drop or velocity through the core will result in an increase in the power obtainable in this fashion; or, briefly, a small change in pressure drop across the core makes a large change in the net power gained. If the radiator-core area were increased 50 per cent to 3.45 sq ft, the velocity through the core would be reduced to 40 fps and the pressure drop across the core would be cut to 4.45 in. H₂O. This would reduce the second factor and increase the first to give a net power gain of 13 hp, or over twice as much.

If the exhaust gases are discharged into the cooling air stream, the further addition of heat results in a considerably larger power gain. The heat in the exhaust amounts to about 1.5 times the brake-horsepower output. The net power gain for this case becomes

$$hp_g \quad 1 - \quad - K \quad bhp - \frac{\Delta p \cdot A V_c}{550} \quad (43)$$

Using the same example as before and assuming the full power of the exhaust as usable, the power gain becomes 70 hp, a considerable amount. Although not mentioned previously, the power thus obtainable is converted into thrust horsepower with

an efficiency of over 90 per cent. This would give an increase of about 8 per cent in the thrust horsepower for the above case, as the propulsive efficiency of the propeller would be about 80 per cent. Such a gain in thrust horsepower is well worth consideration during design operations and should be obtained if at all possible.

The Campini Propulsion System.—An unusual method of aircraft propulsion called the *Italian Campini propulsion system*³, has been investigated with promising results, and should be mentioned here. It involves the use of a large hollow body such

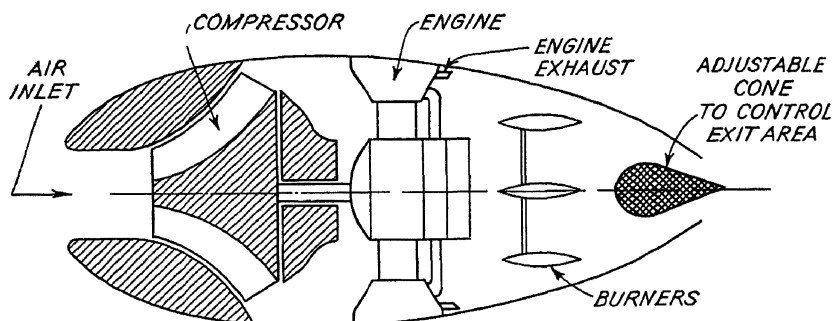

FIG. 193.—Campini jet propulsion system.

as that shown in Fig. 193. An air stream flowing in through the nose is compressed to $1\frac{1}{2}$ to 2 times its original pressure and is passed over the cooling surfaces of the engine used to drive the compressor. After it has cooled the engine, both the engine exhaust and fresh fuel are discharged into this air stream, heating it and causing it to expand through a jet at the rear to provide a considerable thrust at high air speeds. The same general analytic approach may be applied to this problem as to that of the heated duct radiator. The thrust available and the specific fuel consumption compare favorably with the conventional engine-propeller combination at high air speeds, especially above 400 mph where propeller efficiency begins to fall off rapidly.

DESIGN DETAILS

Limitations Imposed by the Coolant.—Water and ethylene glycol are the only two coolants to be widely used in aircraft engines. Water is better in that it has approximately twice the specific heat, a considerably higher heat-transfer coefficient, and

a lower viscosity than glycol. It is much less prone to leak through joints and is readily available at virtually no cost. On the other hand, glycol has the advantage that its freezing point is much lower and its boiling point much higher than is the case for water. The high boiling point makes it possible to operate at much higher temperatures, giving a lower heat rejection from the engine and a greatly reduced radiator size, as was pointed out in the chapter on Cooling.

The British have investigated the use of water under pressure with good results.⁴ They found a solution of 30 per cent glycol in water to be even more promising and have used it. By maintaining 20 psi on the system with a pressure relief valve, it is possible to operate with the same radiator area for the 30 per cent glycol solution as would be required for a 100 per cent glycol solution at atmospheric pressure. The pressurized system has the disadvantage that greater care must be taken to prevent leaks, and it is more vulnerable to gunfire.

The drop in boiling point of both glycol and water with altitude means that the highest critical altitude of the engine will represent the critical design condition. That is, the maximum safe operating temperature must be well below the boiling point of the coolant at that altitude. As shown in the table in Fig. 191, the boiling point of ethylene glycol is 280°F at 27,500 ft. This temperature would be raised considerably by pressurizing the system.

Radiators.—Coolant radiators generally consist of nests of tubes. Air flows through the tubes and coolant flows around them (see Fig. 219). The radiator size may be selected on the basis of charts or data supplied by the engine and radiator manufacturers. The material in the chapter on Cooling, as well as that on intercoolers in the chapter on Induction Systems, will help to give a background for understanding such charts.

Although the radiator location and the size and shape of the cooling-air duct work as related to a particular airplane are primarily problems in aerodynamics, the general arrangements used may be mentioned. Placing the radiator directly under the engine as shown in Fig. 191 gives a compact installation with short coolant lines. Further, ground and take-off cooling is relatively good because the air inlet is directly behind the propeller so that the core is in the propeller slip stream. Drag

considerations may make other locations more desirable. The radiators may be placed in the form of "blisters" on the lower part of the fuselage toward the rear so that they lie in the boundary layer, as in the Mustang fighter shown in Fig. 1. Similarly, heat-transfer surfaces may be placed in "blisters" on the sides of the fuselage, as in the Lockheed P-38 fighters shown in Fig. 194. Placing the radiators inside the wings and providing a cooling-air

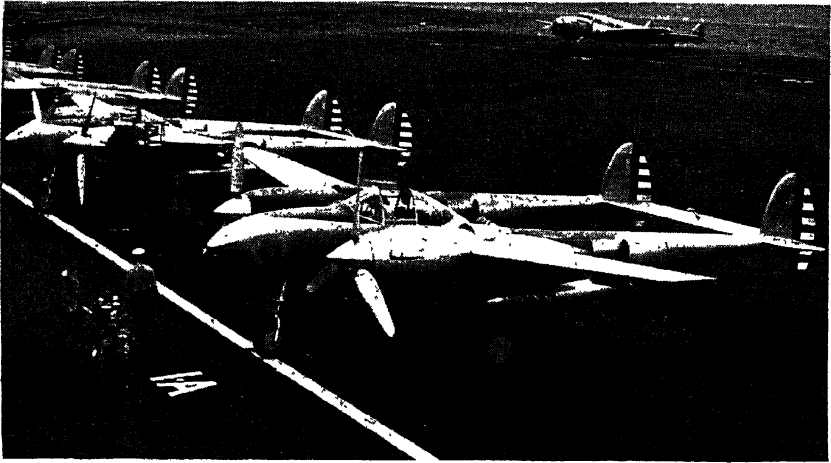

FIG. 194.—Lockheed P-38 fighters being serviced. (*Lockheed Aircraft Corp.*)

supply from openings in the high-pressure region at the leading edge of the wing offers another solution that gives little or no increase in the frontal area of the airplane. Still another arrangement is to make use of the skin of the wing itself as a heat-transfer surface, by circulating the coolant through passages between corrugated sheet and the inner surface of the skin. Difficulty with leaks is inevitably great and has practically ruled this system out because of service troubles.

The thermostat used at the top of the radiator to by-pass the coolant in cold weather may be of either the bimetallic or the gas-filled slyphon type. It is set to open when the coolant has reached the desired operating temperature.

Expansion Tank.—The expansion tank should be located somewhat above the rest of the system so that all locations in the system will be flooded with coolant both in level flight and when the airplane is at rest on the ground. Its capacity should

be 10 per cent of the total capacity of the system, plus 1 gal. The filler opening should be so arranged that the tank cannot be filled completely on the ground, for extra space is needed to allow the coolant to expand when it is heated. A pressure relief valve may be provided to give pressurization at altitude.

References

1. MEREDITH, F. W.: Note on the Cooling of Aircraft Engines with Special Reference to Ethylene Glycol Radiators Enclosed in Ducts, *Brit. R & M* 1683, 1934.
2. RAUSCHER, M., and W. H. PHILLIPS: Propulsive Effects of Radiator and Exhaust Ducting, *I.A.S. Jour.*, vol. 8, No. 4, February, 1941.
3. CAMPINI, S.: Analytical Theory of the Campini Propulsion System, *N.A.C.A. Tech. Mem.* 1010.
4. ELLOR, J. E.: A Brief Survey of the Principles of Pressure Water Cooling, *S.A.E. Trans.*, vol. 51, 1943.

CHAPTER XIX

INDUCTION SYSTEMS

Although generally short and simple in appearance, engine induction systems are very important and present serious problems in design. Since the velocity pressure of the entering air may amount to as much as 3 in. Hg for high-speed flight, it represents a valuable source of supercharge which may increase the critical altitude of the engine by 5,000 ft. On the other hand, unnecessary restrictions will result in a reduction in the power available above the critical altitude. What is even more important, any disturbance in the air stream flowing through the carburetor caused by such restrictions will result in erratic metering of the latter and faulty engine operation.

INLET OPENINGS

Available Ram.—The increase in static pressure at the carburetor inlet, or “ram,” available from the dynamic pressure of the air stream is the same as that given for the available baffle pressure drop across a cowling (see Fig. 183). Since supercharger pressure ratios run on the order of 2.0 at rated rpm, a change in carburetor inlet pressure represents a change of twice that amount in manifold pressure. Engine full-throttle power output will be increased about 3 per cent by an increase in manifold pressure of 1 in. Hg, *i.e.*, about 6 per cent by an increase in carburetor air inlet pressure of 1.0 in. Hg if the supercharger has a pressure ratio of about 2:1. This increase will be offset somewhat by the increase in carburetor air inlet temperature due to the adiabatic compression from atmospheric conditions, but a net gain in power of the order of 15 per cent is obtainable at air speeds of 350 mph or more. It should be noted, however, that the increase in carburetor air temperature due to ram may be responsible for detonation in low-altitude flying. If the ambient air temperatures are above 80°F, the temperature rise due to ram may amount to over 30°F. This would give dangerously high carburetor inlet temperatures.

The effectiveness of the air inlet in taking advantage of the ram potentially available is normally found by measuring the static pressure at the carburetor inlet flange. The losses in the duct, as well as the velocity pressure of the air flowing past the carburetor inlet, cause this increase in carburetor air-inlet static pressure to be somewhat less than the dynamic pressure of flight. An empirical formula used to check air scoops under rated-power high-speed flight operation at sea level is

$$\text{Ram} = 45.2 - 2 \text{ in. H}_2\text{O} \quad (44)$$

This includes the effects of duct losses and the air velocity at the carburetor inlet. A well-designed air scoop should give the ram indicated by this formula. As pointed out in the chapter on Performance, restricting the air supply to the carburetor does not result in a loss in power unless the engine is operating at full throttle. Take-offs at altitudes above about 3,000 ft and all high-speed or climb performance at or above the rated critical altitude of the engine involve engine operation at full throttle. Under these conditions the effectiveness of the induction system in providing ram is of vital importance.

Air-scoop Drag.—Like the engine cowling, the air scoop is responsible for a certain increment of airplane drag. The location of the air scoop should be such that it causes little increase in drag and yet provides a maximum amount of ram. If the inlet opening is placed in a region of high pressure such as the leading edge of the cowling and properly faired in, the increase in drag may be very small and yet the scoop may give 90 to 97 per cent of the ram ideally available. Installations of this type can be seen in Figs. 1, 2, 163, and 178. The details for any particular installation must be worked out by aerodynamics experts.

Effect of Flight Attitudes.—Flight attitudes may have considerable effects on the carburetor air-scoop inlet because of changes in air flow. An air scoop located a short distance back from the front of the cowling may be in a region of low pressure in a climb, thus giving carburetor air inlet pressures considerably below atmospheric. This, in turn, may result in a serious loss in engine power under take-off conditions. Further, air that has circulated over the fronts of the cylinders inside the cowling may

spill out the top and go back into the air scoop. There have been cases in which this has resulted in carburetor air inlet temperatures of as much as 40°F above the prevailing atmospheric temperature. Such temperature increases cause a loss in power of 1 per cent for every 10°F temperature increase and, even worse, are likely to cause detonation. Under hot-weather conditions, the cumulative effects of the increased carburetor air inlet temperature and decreased pressure have been known to result in a loss in engine power of 10 per cent or more. Air leakage of this sort can be prevented by the use of an "eyelid" that blocks off the portion of the opening at the top of the cowl from which the heated air commonly spills. The cowling in Fig. 178 shows such a device.

Icing.—Engine induction systems have been subject to three principal types of icing.¹ The first is the freezing out of water vapor, rain, or sleet in the air when chilled by the evaporation of fuel below the carburetor jets. Much of the hazard from this source was eliminated with the advent of "nonicing" carburetors, which made use of throttles located above the fuel nozzles so that fuel evaporation could not cause ice to form on the throttles and render them inoperative. Even so, ice may form below the throttles and choke the carburetor adapter.¹ The second type is freezing of moisture at the throttle due to the temperature drop accompanying the pressure drop at that point. Both types occur in or below the carburetor. A third hazard is presented by "intercepted ice" under "atmospheric icing conditions," which cause ice to form on the wings, cowling, propeller, etc. Under such conditions, ice may form at the air-scoop inlet, blocking it off completely. Recent tests show that the rate at which ice deposits form depends on the forward-projected area of the region in question. That is, the water or sleet particles do not follow the streamlines but move in substantially straight lines to deposit out on the first bit of surface to intercept them. The rate at which the ice forms depends on the amount of moisture per cubic foot of air and the velocity of the airplane. It is quite possible for an airplane to run into icing conditions very abruptly, especially at night. In flying at a speed of 200 mph or more, the air scoop may be completely blocked off by ice in 60 sec. A fast, low-flying airplane with a suddenly acquired ice burden and a dead engine loses altitude too rapidly

for the pilot to have much chance even to try to start the engine if it once "cuts out."

Figure 195 shows the ranges of carburetor air inlet temperature and air water content that cause ice to form in an induction system with a nonicing carburetor. Note that, if the water content of the air can be kept low enough or the temperature high enough, ice can be prevented. Note also the location of these regions with respect to the lines of constant relative humid-

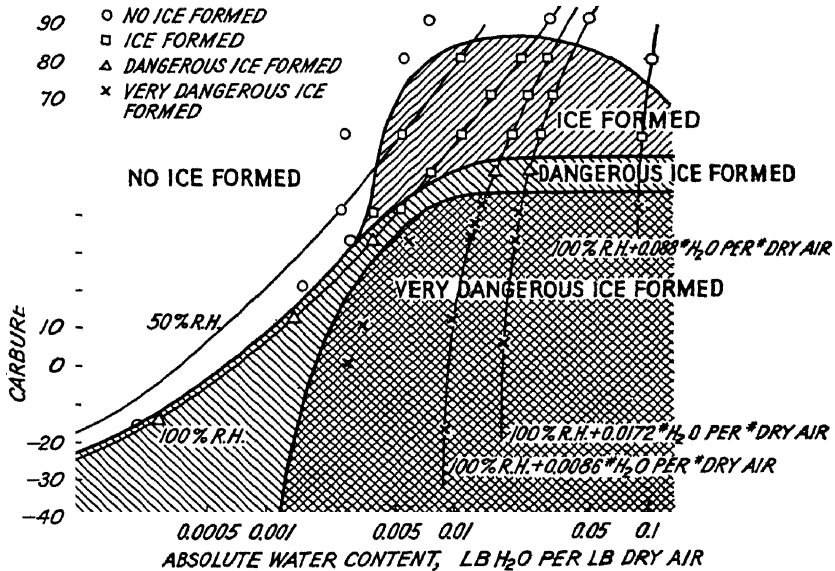

FIG. 195.—Effect of temperature and water content of the air supplied to the carburetor on icing in the induction system. (Skoglund, *I.A.S. Jour.*, vol. 8, No. 12, October, 1941.)

ity and moisture content. The conventional method of handling the icing problem in the past has been to employ an auxiliary source of heated air or else to make provision for the injection of alcohol against the surfaces susceptible to icing and, in that way, break up the ice formations. The former method, in particular, has been widely and successfully used and will be discussed in detail later.

One way of preventing icing of the air-scoop inlet is to make use of a scoop like that in Fig. 196. Since it presents no surface on which ice can deposit, it is free of icing trouble as has been demonstrated by actual tests. Further, it does not intercept

and scoop in rain so that the air delivered to the carburetor has an absolute moisture content of not more than that for 100 per cent relative humidity. Figure 195 indicates that this sort of induction system is free of dangerous icing for all but a narrow range of conditions. Since the duct is exposed to engine heat, a temperature rise of 5 or 10°F would probably occur between

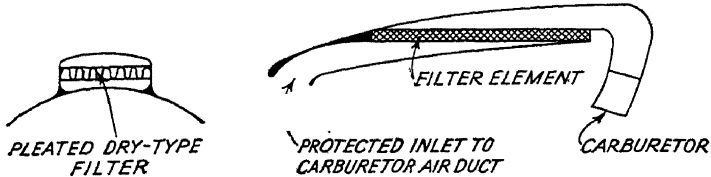

FIG. 196.—Sections through an induction system containing an air filter.

the inlet and the carburetor, thus giving safe operation under all conditions. Although this scoop should give about the same amount of ram as other types, it has what might prove to be a serious disadvantage in that it tends to receive air heated by circulation over the fronts of the cylinders, especially at take-off or in a climb.

DUCTS

Carburetor Metering.—Possibly the most important consideration in duct design is the effect of the induction system on

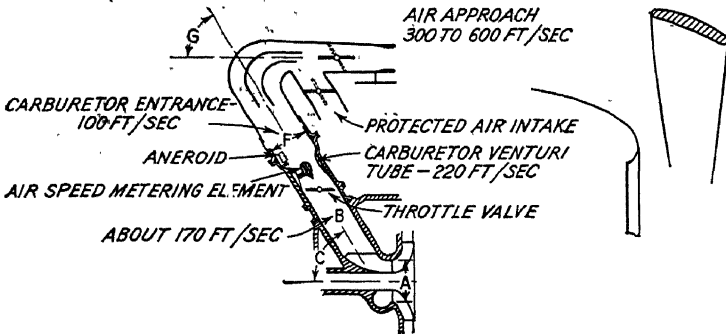

FIG. 197.—Complete air-intake system, showing discrepancies between internal and external air velocities at rated power at sea level. (*Mock, S.A.E. Trans., vol. 50, 1942.*)

the metering of the carburetor. Figure 197 shows a recently developed arrangement for an engine with no auxiliary-stage supercharger. Although this system displayed good characteristics because of the care taken in its design, it shows the possi-

bilities for trouble inherently present. Note the velocity variation through the system. Note, too, the sharp bend in the duct just ahead of the carburetor air metering venturis. When one considers that fluid-flow measuring-test codes ordinarily require that a minimum of 10 diameters of straight pipe precede the metering orifice to ensure smooth flow into the orifice and consistent results, it is not surprising that carburetor metering

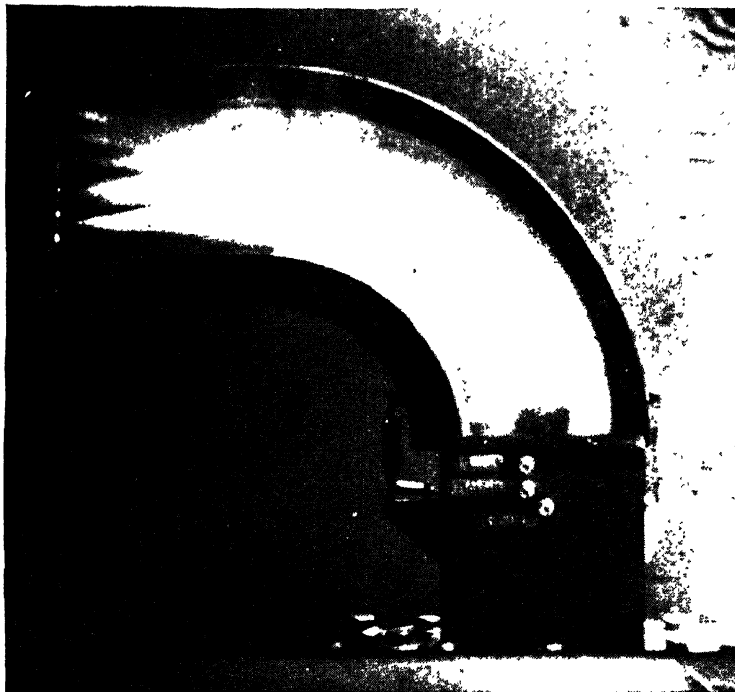

FIG. 198.—Motion-picture “still” showing kerosene smoke flowing through elbow into carburetor. (*Mock, S.A.E. Trans.*, vol. 50, 1942.)

characteristics have often proved erratic in flight tests. Air-flow patterns at the scoop inlet change with airplane speed and attitude, the variations between climb, level flight, and diving being particularly pronounced. Such changes will produce irregularities in flow which are superimposed on those inherent in the induction system. Changes in air velocities through the scoop and into the carburetor will occur with changes in engine power output or in altitude, giving additional factors affecting the flow pattern at the carburetor inlet and through the venturis.

The precise effects of changes in flow pattern at the carburetor inlet depend on the particular carburetor. Any carburetor, however, meters on the basis of the pressure differential between the inlet to and the throat of a venturi. This, in turn, means the use of small holes located at representative points in the air stream. If the velocity distribution across the air stream is uniform, the pressures at these holes will be representative, and the air flow through the carburetor will be definitely related to them. Changes in the velocity distribution will, in general,

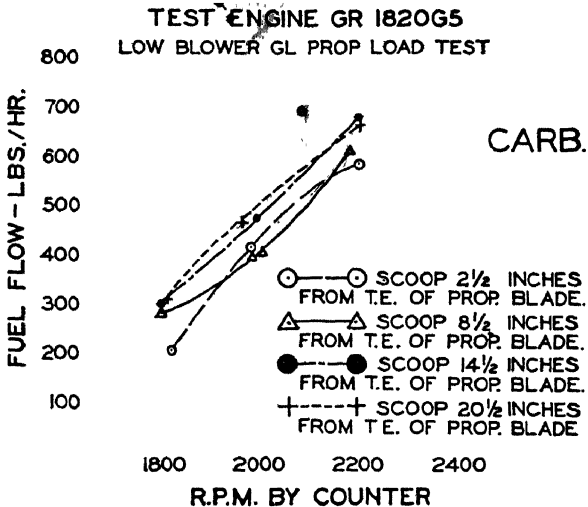

Fig. 199.—Effect of the length of the forward extension of an air scoop on the carburetor metering characteristics. (*Mock, S.A.E. Trans., vol. 50, 1942.*)

cause the pressures at these small holes to be either more or less than that representative of the mean velocity across the section, thus causing the carburetor to give a fuel-air mixture that is either too rich or too lean. Figure 198 shows a smoke-flow study of a large-radius scoop elbow. Note the poor velocity distribution and flow separation at the carburetor entrance below the bend as indicated by the smoke concentration at the rear of the duct. The poor velocity distribution due to this elbow would cause the carburetor to meter quite differently from what it would with a uniform velocity distribution.

Some idea as to the possible magnitude of what seem to be small variations in the air scoop is given by Fig. 199, which shows curves of the fuel flow given by the carburetor against rpm on a

ground propeller-load curve. Four different air scoops were tested with an engine on a regular test stand. The scoops were of conventional form, differing only in the length of the duct extending forward toward the propeller. The curves show metering variations of the order of ± 10 per cent due to simply changing the air scoop length. For flight work, these variations would become even greater owing to changes in air flow with airplane altitude, etc., so that the possible spread of the curves becomes hopelessly large. Yet service conditions demand a carburetor that will meter consistently within ± 3 per cent. Carburetor and engine manufacturers have spent millions of dollars to develop such carburetors. Airplane manufacturers should take advantage of this development work by using air scoops that give the carburetors reasonably smooth air flow to allow them to function properly.

The method first tried in coping with the problem was to work out a special carburetor setting for each airplane. This met with some success because the flow pattern for a particular installation is fairly uniform. A duct like that shown in Fig. 198, for example, always gives essentially the same velocity distribution with a particular air flow; and thus, by changing jets, air bleeds, needle contours, etc., in the carburetor, it can be made to give approximately the proper mixture for average flight conditions. This method has the disadvantage that long and costly flight testing is necessary to work out a setting. When the setting is obtained, carburetors for use in that airplane cannot be used on the same engines in another airplane of a different type, thus greatly complicating maintenance problems.

A more promising method is to try to modify the air duct so that it delivers air to the carburetor inlet in a smoothly flowing stream having a uniform velocity distribution. This can usually be accomplished by careful design coupled with flow testing of the duct. Kittler,³ in discussing the problem, gave a number of precepts common to other fluid-flow problems. These are included below, together with recommendations made by Mock.⁴ If followed, an installation giving good carburetor metering characteristics may reasonably be hoped for.

Duct Design.—The shape and cross-sectional area of the duct should be made as uniform as possible, especially in diverging sections, to reduce flow separation and turbulence. Where

diverging sections are necessary, the change in section should be gradual. The maximum amount of straight duct should be used immediately ahead of the carburetor, for a few extra inches may help a great deal. The cross-sectional area should be kept between 75 and 100 per cent of the carburetor inlet area throughout the length of the duct, including the entrance. Since a considerable deceleration of the air stream occurs ahead of any stagnation point in which the entrance is likely to be located, the resulting entrance area will not be excessively large even for very high speed flight. Further, the air-stream deceleration ahead of a stagnation point gives a more efficient compression than a well-designed diffuser. Then, too, a smaller entrance constitutes an appreciable restriction that might seriously limit the power available for climbing at or above the critical altitude.

Elbow Design.—In rectangular ducts, sharp bends of short radius have been found to give lower pressure losses and smoother flow conditions than medium-radius bends. This has been demonstrated in many branches of engineering. Investigations of the problem have also shown the marked superiority of high “aspect ratios” in the duct at the bend; *i.e.*, the shorter the cross-sectional dimension in the plane of the curve, the lower the losses for a given cross-sectional area. Since considerations such as space available for a duct over the top of a cowl generally favor a wide flat duct, this is usually not hard to provide. If other considerations such as the shape of the top deck of the carburetor require a more nearly square duct, turning vanes may be used in the bend to give the effect of several high-aspect-ratio passages. Turning vanes have the disadvantage that they form an obstruction on which atmospheric ice may deposit and block the induction system. If bends or obstructions are placed ahead of the vanes, the former would be the first to accumulate atmospheric ice and this objection would not apply.

Provisions for Carburetor “Heat.”—The icing problem mentioned above is commonly anticipated by providing an auxiliary air inlet so arranged that hot air instead of cold may be fed to the carburetor. The air may be heated by either the exhaust manifold or the engine. In the former case, an “intensifier tube” may be run up through the exhaust collector ring and the carburetor air drawn through it (see Fig. 206). An alternative is to jacket the exhaust collector ring with the inner cowl and

pass the air up over the collector ring. Since this does not heat the air to so high a temperature as the intensifier tube, it is not likely to give dangerously high carburetor air inlet temperatures. The other method, that making use of the heated air leaving the engine baffle passages, requires no extra duct work (see Fig. 197).

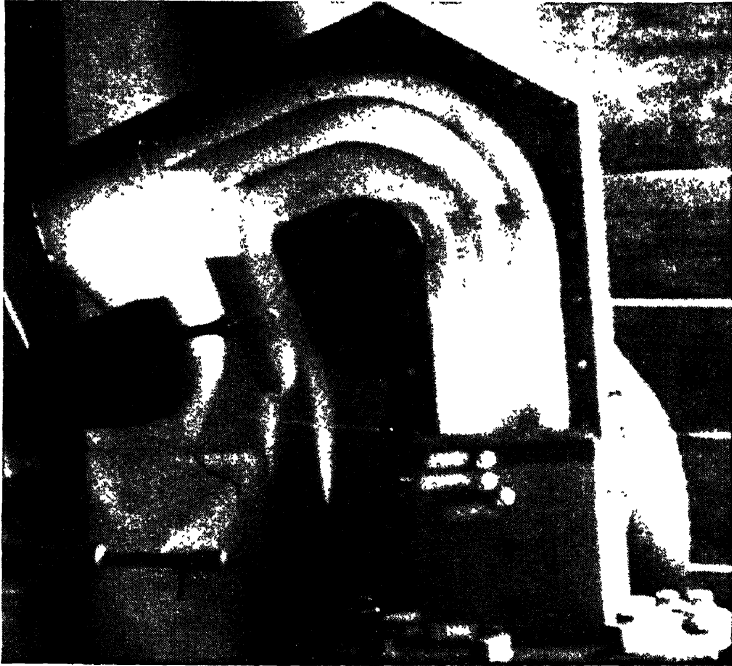

FIG. 200.—Smoke-flow study of air flow through the protected air intake of the induction system shown in Fig. 197. (*Mock, S.A.E. Trans., vol. 50, 1942.*)

Heater-valve Design.—A door, or valve, is used to admit hot air to the carburetor when icing conditions are encountered (see Fig. 197). Although not mentioned previously, the heater valve is one of the most important of the factors disturbing carburetor metering. When opened either partly or wholly, it should not disturb the air flow into the carburetor, nor should it give segregated streams of hot and cold air. The latter type of difficulty is particularly bad if one of the streams completely engulfs the automatic-mixture-control unit, causing it to make the carburetor meter as if the entire air stream were the temperature and density of the portion flowing around the control unit.

Care must also be taken to locate the sensitive element of the carburetor air thermometer in a representative portion of the air stream. If located in a cold portion, for example, the heater valve might be opened too far and dangerously high carburetor inlet air temperatures actually obtained in spite of low thermometer readings.

To satisfy all these requirements best, the heater valve should be located as far as possible from the carburetor, preferably ahead of the elbow in the duct. If straightening vanes are used, they may be carried forward as in Fig. 197 to be effective in giving smooth flow for all valve positions. Figure 200 shows a smoke-flow study of this arrangement. Note that the valve itself acts as a guide vane.

Slip-stream Pulsation Effects.—The pulsations in the propeller slip stream may be transmitted into the carburetor air duct. This may be serious if the natural frequency of the air column in the duct is about the same as the frequency with which the propeller blades pass the duct inlet. Also, certain flight attitudes such as diving may cause the air stream to strike the inlet opening at an angle so that pressure waves are induced in the air-duct air column. Resonance is then likely to occur. The effect is similar to that obtained by blowing across the open end of any open pipe such as a flute or an organ pipe. Whether due to propeller-blade impulses or air-stream turbulence, such pressure fluctuations may seriously upset carburetor metering. As a rule, they cause mixture enrichment.

FILTERS

Engine Wear.—Dust and fine sand taken into the induction system may cause extremely rapid piston, piston-ring, and cylinder-barrel wear. This is particularly likely in military work in which squadrons take off in formation from the unpaved runways of emergency fields. The leading airplane usually raises a considerable amount of dust, which is intercepted by those behind. Not only is the problem acute in such places as desert country, but on the sandy piedmont of our southeastern states engine wear may be so rapid that overhaul is required after less than 100 hr of engine operation. In sandy desert country, a new engine may become so worn after 35 to 50 hr of operation as to be worthless.

Filter Types and Performance.—A satisfactory aircraft-engine air filter must remove the bulk of the dust from the air passing through it and yet cause only a small loss in ram. Further, it should be sufficiently compact to be fitted into induction systems not specifically designed for it and should be light in weight. Most of the several types of air filter in use in other industries are not suitable. Water-spray air cleaners are out of the question. Oil-bath air cleaners, which have been successfully used in trucks, tractors, and stationary diesel engines, are too bulky and heavy, beside being unsuited to maneuvering. Dry-type filters of felt or other fabric of ordinary design have been used with some success, but they offer a high resistance to air flow and clog rapidly. Modifications of this type make use of many folds of cloth to provide a large filter-element area (see Fig. 196). They also generally incorporate a deflector of some sort to make the air travel around a bend before it reaches the filter cloth. The bulk of the larger sand and dust particles are thrown to the outer circumference of the bend, where small vents allow some air to escape to carry the particles off. Thus “centrifuged,” the air can then be passed through the cloth filter to remove the remaining dust. These filters have proved to be satisfactory under the worst conditions of desert warfare.

The washable viscous impingement type widely used on automotive equipment has also been satisfactory. It consists of a loosely woven mat of metal wire and ribbon that has been dipped in ordinary lubricating oil. Since air flowing through such a filter has to follow a tortuous path, the dust particles tend to move in straight lines and impinge on the oil-coated surfaces, where they are caught and held. To prevent rapid clogging, the filter element is made loose and open at the front but is packed progressively tighter toward the rear. This causes the dust caught by the filter to be fairly evenly distributed throughout the element instead of being concentrated at the front, giving a maximum dust-holding capacity with a minimum rate of rise in pressure loss across the filter. Filters of this type need only be removed, washed in gasoline, dipped in oil, drained, and reinstalled whenever they get dirty, thus presenting no replacement problem in the field. A number of such filters differing somewhat in their characteristics are available. A typical unit consists of a 2-in.-thick filter element of braided steel wire and copper ribbon

held in a welded frame of light-gauge sheet-steel channels. It may be used with air velocities of as high as 1,000 cfm per sq ft of filter area and still give a pressure drop of less than 4 in. H_2O . Its weight would be about 12 lb for an 1,800-hp engine.

The size, weight, and pressure drop of the filter shown in Fig. 196 are essentially similar to those of the unit described, and thus they present similar installation problems. Regardless of the type of air filter used, frequent cleaning is necessary under adverse conditions. The installation should make removal a simple, easily accomplished task.

AUXILIARY-STAGE SUPERCHARGER INSTALLATIONS

Space Limitations.—Auxiliary-stage superchargers have greatly increased the complexity of engine induction systems. The requirements and general layout of the installation for a gear-driven auxiliary stage are essentially similar to those for the exhaust turbo type. Actual installation in the airplane, however, is much simpler for the former; for it is not too difficult to find space for the extra duct work and the intercoolers, while the auxiliary stage itself is in the engine and increases the engine length by only about 6 in. As a result, a neat and compact installation can be made. The exhaust turbosupercharger, on the other hand, is relatively bulky. In pursuit ships in particular, it is extremely difficult to find space in the vicinity of the engine without seriously upsetting the basic design of the airplane. Since it is also desirable, if not essential, to reduce the exhaust gas temperature before it reaches the turbine buckets, the turbosupercharger is ordinarily mounted well aft of the engine.

Standard Symbols.—Design of equipment for auxiliary-stage superchargers has introduced a whole new set of variables. Because of the confusion resulting from the many different symbols in use, the S.A.E. set up standards for the symbols to be used in formulas involving these variables. Figure 201 gives a standard induction system for an exhaust turbosupercharger and defines the symbol for each temperature and pressure. The diagram for the two-stage gear-driven supercharger is the same except that the long exhaust manifold and turbine are omitted. Each of the large number of pressures and temperatures defined in this figure is important and is related to the others. Tracing the induction system from the inlet to the air scoop at the top

center of Fig. 201, one finds that the subscripts indicate the conditions of the air at various points in the system, as follows: a denotes atmospheric conditions; r , the pressure and temperature rise due to ram; b_1 , the inlet to the impeller of the first auxiliary stage (the numerical subscript is used because there might be two auxiliary stages in some installations); d_1 , the diffuser outlet of the auxiliary stage; u and f , the engine air at the intercooler inlet and outlet faces respectively; k and h , the cooling air at

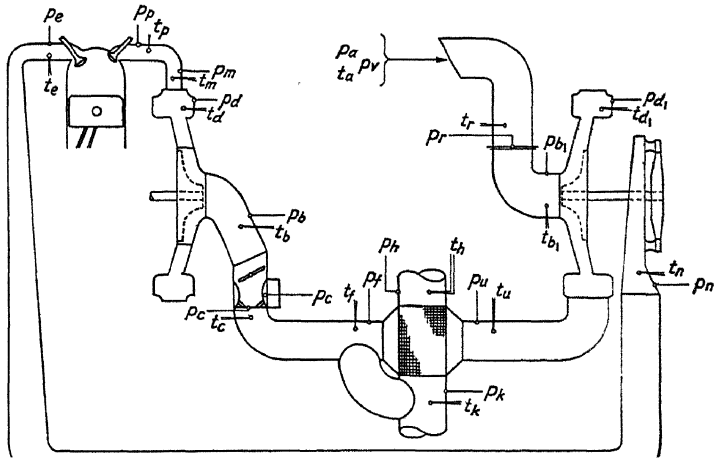

FIG. 201.—Standard symbols for the temperatures and pressures in the induction system for an aircraft engine equipped with a gear-driven main-stage and a turbo-driven auxiliary-stage supercharger. (*S.A.E. Aeronautical Standards, AS21.*)

the intercooler inlet and outlet faces respectively; c , the carburetor; b , the main-stage impeller inlet; d , the main-stage diffuser outlet; m , the intake manifold; e , the exhaust manifold; and n , the turbine nozzle box. Note that provision is made for temperature and pressure changes in open ducts such as in that from the intercooler to the carburetor. Ordinarily, such changes will be small, but they must be considered, partly because precise work requires it and partly because they may be large in long ducts.

The temperature rise through the auxiliary stage at low altitudes may be great enough to cause detonation even though the pressure rise is negligible. Since the main stage alone provides the maximum manifold pressure that may be used, the

temperature rise through the auxiliary stage may be avoided by employing a by-pass duct and valve from the intercooler inlet side of the cooling air duct to the intercooler outlet side of the engine air duct. A by-pass of this sort is shown in Fig. 201. A further advantage of such a by-pass is that it avoids the pressure drop that would otherwise occur in a gear-driven auxiliary stage when the impeller of the stage is declutched.

Usual Specifications.—Military specifications for multistage supercharger installations are based on engine requirements. To ensure freedom from detonation caused by high intake-manifold air temperatures, they require that the carburetor air inlet temperature never exceed 100°F and normally be kept below 90°F. To ensure a reasonably efficient installation, the pressure drop in the engine air duct across the intercooler must be kept below 1.25 in. Hg at normal sea-level rated power. Similarly, the total pressure drop from the first stage compressor to the carburetor may not exceed 1.75 in. Hg. For duct and intercooler design purposes, the air flow to an engine may be taken as being 0.110 lb/(bhp)(min). The entire system must take 20 psi without damage or leakage, this being an indication of its ability to withstand backfires. Because of the great complexity of control, an automatic-control arrangement is absolutely required to maintain the manifold pressure to the value set by the pilot without attention from him.

INTERCOOLERS

The hot air discharged from the auxiliary stage of the supercharger may be cooled by passing it over heat-transfer surfaces cooled by air taken from the air stream. Such an intercooler must effect the necessary cooling with a minimum pressure loss in both the engine and the cooling air streams and must use a minimum amount of cooling air. It should be pressure tight so that no leakage of engine air may occur, it must be as light and as compact as possible, and it should not be damaged by engine vibration or backfiring.

Construction.—Space limitations, together with ducting problems and manufacturing difficulties, have centered attention on the cross-flow type of intercooler, since the loss in efficiency for the working range desired is small as compared with the ideal counterflow type. Two types of construction are commonly

used. In one, the engine air is passed through tube banks across which is directed the cooling air. In the other, flat and corrugated plates are stacked alternately, with the direction of the corrugations so arranged that cooling air flows across the intercooler through every other layer, while engine air flows at right angles to it through the intervening layers. Both types of intercooler have been built of either aluminum or copper. The plate type, when made of copper, requires such thin sheet to obtain a reasonable weight that the units are susceptible to backfiring, a single backfire often completely collapsing the plates. With aluminum sheet, the thickness can be increased to the point where a backfire will not cause damage. If the engine air is directed through rather than across the tubes, the tubular type of intercooler will not be subject to damage by backfires even if made of very thin copper tubes.

Basic Heat Transfer.—Theoretical analyses of heat transfer in cross-flow intercoolers are quite complex, but their more important results can be deduced rationally from the basic heat-transfer equation. Such deductions, coupled with typical test results, indicate the general characteristics of this equipment. Consideration of the problem shows that it consists of two similar parts: the heat transfer from the hot engine air to the metal plates or tube walls, and the heat transfer from the plates or tubes to the cooling air. The surface films involved are the principal barriers to heat flow, for the thin metal itself has a negligible effect. The basic heat-transfer equation

$$H = hA \Delta T$$

shows that, for a given intercooler, the amount of cooling will depend on ΔT , the temperature difference between the engine air and the cooling air, and on h , the surface heat-transfer coefficient.

Ratio of Temperature Drop to Temperature Difference.—The most important factor in intercooler performance is the ratio of the temperature drop in the engine air to the temperature difference between the engine air inlet and the cooling air inlet temperatures. This is easily seen from the basic equation above; for the engine-air specific heat is essentially constant, and, since the amount of heat transferred is proportional to the temperature difference, the ratio of temperature drop to temperature difference should remain constant for a particular intercooler

if the heat-transfer coefficient does not vary. Therefore, with given engine and cooling air flows, this ratio will remain essentially constant regardless of engine air or cooling air temperatures. Thus it constitutes the most useful and commonly used parameter in intercooler work. On intercooler design charts, it is often expressed as the temperature drop per 100°F temperature difference to make it more easily used by those not familiar with intercoolers.

Effect of Tube Length and Diameter.—Consider first a single tube with engine air flowing through it and cooling air flowing across and perpendicular to it. Based on the symbols defined in Fig. 201, the temperature drop in a unit length of tube will be

$$t_u - t_s = K(t_u - t_k)$$

where t_s is the engine air temperature leaving the tube, and K is much less than 1. For a tube of twice that length,

For a tube of any length l ,

$$t_u - t_s = K^l(t_u - t_k) \quad (45)$$

This is the familiar exponential curve commonly found for this type of relation.

Since both the fluid flow and the heat transfer are essentially a function of the geometry of the intercooler, it has been found that the significant parameter is not tube length but rather the tube length-diameter ratio. For the range in dimensions likely to be found in intercoolers, intercooler characteristics at a particular tube length-diameter ratio are independent of tube diameter. Thus, if high temperature drops are required, it can be seen from the above that these may be obtained by increasing the tube length and keeping the diameter fixed or by keeping the same length and reducing the diameter.

Temperature Distribution in an Intercooler.—The temperature distribution through an intercooler is difficult to find precisely but is readily indicated approximately. Figure 202 shows a three-dimensional plot of the temperature of both engine air and cooling air in a plane parallel to the directions of flow of both air streams. The engine air temperature across the inlet face would be constant, giving the line ab . The engine air tempera-

ture would drop along the cooling-air inlet face according to Eq. (45), giving the exponential curve ac . The temperature of the air leaving successive tube banks is commonly assumed to vary linearly, giving the straight line cd across the engine-air exit face. The curve bd along the cooling-air exit face is another exponential curve similar to ac . A similar surface, but inverted and rotated 90 deg, gives the temperature distribution in the cooling air stream. This surface is defined by the lines $efhg$. This representation, though not exact, is a close approximation. It shows clearly that the temperature distribution is not uniform across either exit face of the intercooler.

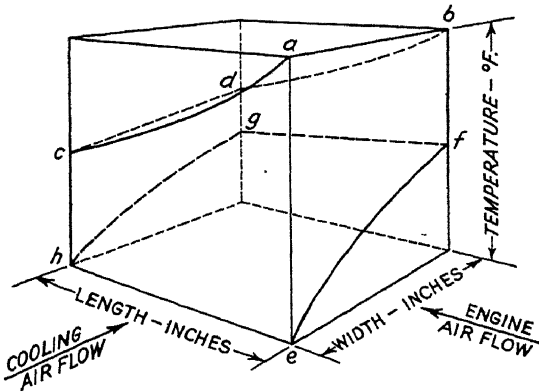

FIG. 202.—Theoretical temperature distribution through a typical layer of an intercooler.

Effect of Mass-Flow Ratio.—As was pointed out in the chapter on Cooling, the heat-transfer coefficient for the air film on a heat-transfer surface is not far from being proportional to the mass air flow across that surface. As a result, doubling the air flow through an intercooler has little effect on the temperature drop per degree temperature difference if the ratio of cooling air flow to engine air flow is kept constant. If one air flow is held constant and the other varied, the heat-transfer coefficient on the first side remains fixed while that on the other side varies linearly with the flow. Increasing the cooling air flow while holding the engine air flow constant, for example, gives an increase in the engine air temperature drop (see Fig. 203). To increase the amount of cooling in this manner may often be more desirable than to increase the tube length. But, as shown in

Fig. 203, the returns diminish so rapidly that the ratio of cooling air to engine air mass flow is usually kept between 1 and 3.

Effect of Air Flow on Pressure Drops.—Just as is the case with the air flow through the baffle passages of an air-cooled engine or through the radiator core of a liquid-cooled engine, the pressure loss across an intercooler in either the engine or the cooling air stream varies approximately as the square of the air flow. Since the mass flow of air is generally the important consideration and since, as shown before, this is a function of the product of the pressure drop and the altitude-density ratio $\sigma \Delta P$,

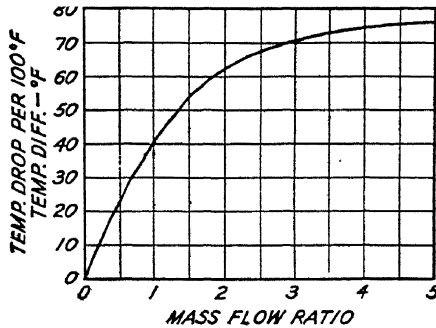

FIG. 203.—Effect of the ratio of cooling air flow to engine air flow on the engine-air temperature drop through an intercooler.

intercooler charts commonly make use of this quantity as a parameter.

Intercooler Performance Curves.—A set of curves such as that in Fig. 204 gives a complete picture of the characteristics of a particular type of intercooler core section. These curves show supercharger air $\sigma \Delta p$ and cooling air $\sigma \Delta p$ plotted against their respective air flows, and a network of curves for *cooling effectiveness* (*i.e.*, temperature drop per degree temperature difference) plotted against supercharger air flow. Each curve of the network is for a particular cooling air $\sigma \Delta p$, *i.e.*, cooling air flow. The engine-air pressure and temperature drops can be computed directly from these curves on the basis of a given cooling air temperature and $\sigma \Delta p$, intercooler size, engine air-intercooler-inlet temperature, and engine air-weight flow. A careful examination of the curves will show the way in which the effects noted above are evidenced.

Intercooler Selection.—Because of the many variables involved, the selection of the optimum intercooler for a particular installa-

tion must be something of a trial-and-error proposition. Ordinarily, however, practical considerations dictate the principal limitations. An intercooler for an engine-driven auxiliary-stage installation usually must be as small as possible, which means that the maximum allowable pressure drops across the core should be used. The specifications would give maximum allowable carburetor air inlet temperatures of about 90°F with some

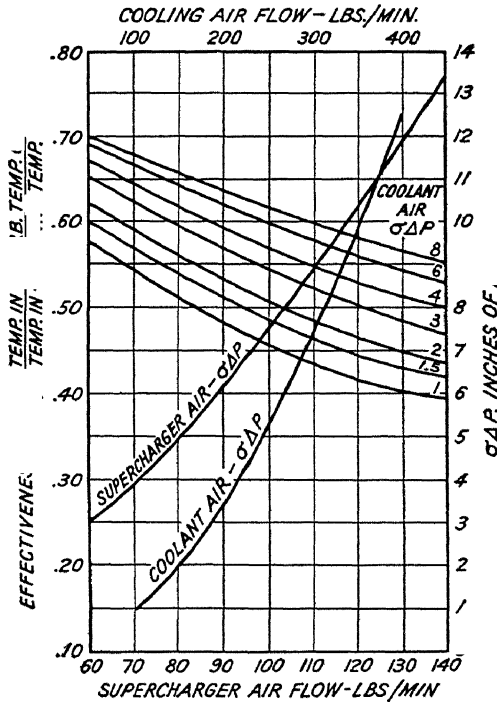

Fig. 204.—Intercooler performance curves for a core section of a given tube length. (Air Research Manufacturing Co.)

particular set of standard atmospheric air temperatures, and the maximum engine air pressure drop permissible. The temperature rise in the auxiliary stage is fixed for a particular supercharger gear ratio, as is the engine air flow at rated power. Because of the large effect of the cooling air density, rated power at the critical altitude represents the critical design condition. The best climbing speed at that altitude ordinarily limits the cooling-air pressure drop obtainable. Thus the ratio of the temperature drop to the temperature difference is specified, as

are the engine and cooling air densities and pressure drops and the engine air flow.

The available cooling-air pressure drop usually limits the depth of the intercooler in the cooling air direction to about 10 or 12 in. Engine air-flow and pressure-drop requirements make a certain minimum engine air face area necessary, thus determining the height. The temperature-drop requirements will then simultaneously determine the tube length and the amount of cooling air flow. If the resulting intercooler is not satisfactory, a dimension in the cooling-air direction giving more promise may be tried and the process repeated. Such calculations can be easily

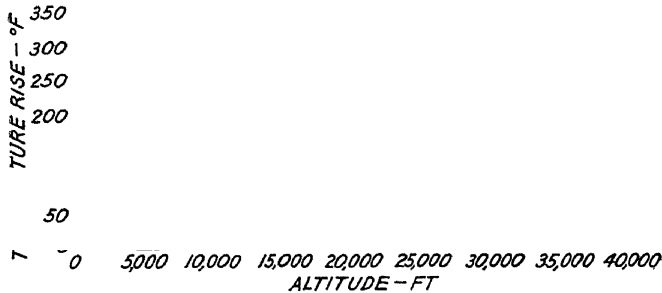

Fig. 205.—Temperature rise through an auxiliary-stage supercharger as a function of altitude if air is compressed from standard altitude conditions to 29.92 in. Hg abs. pressure with a supercharger temperature coefficient of .65.

carried out by using design charts available from the intercooler manufacturers. These are often similar to Fig. 204.

Exhaust-turbo installations present more of a problem. In their case the temperature of the engine air leaving the auxiliary stage depends on the altitude, as the impeller speed is varied to give an essentially constant pressure at the carburetor inlet. Figure 52 shows the supercharger outlet temperature plotted against altitude as calculated on the basis of a supercharger temperature coefficient of 0.65 and standard altitude temperature. Figure 205 shows the temperature difference between the engine air and the cooling air based on the same data as Fig. 52. It does not include the effects of ram, which should be considered in high-speed airplanes, as a considerable increase in cooling air temperature may result. From this curve it is evident that rated-power operation at the critical altitude is again the most critical design condition, for the temperature drop required per degree temperature difference is greatest at that point. Of

course, the best climbing speed also limits the cooling-air pressure drop and its effects should also be checked. If minimum intercooler volume and weight are vital, one may proceed as was done with the engine-driven auxiliary-stage installation. However, the resulting intercooler will probably be considerably smaller than that for optimum performance.

Effect of Intercooler Size on Engine Performance.—For operation above the critical altitude a considerable increase in engine power output can be obtained by using an intercooler larger than that meeting the minimum specifications. Engine power output above the critical altitude increases inversely as the square root of the absolute temperature, or about 1 per cent for every 10°F decrease in carburetor air temperature. A power increase of about 1 per cent may be obtained for every reduction of 2 in. H₂O in engine-air pressure drop across the intercooler because of the resulting increase in full-throttle manifold pressure. Then too, a sizable decrease in the power required to force both the engine air and cooling air through the intercooler may be obtained by increasing its size. These gains will much more than offset the increased weight for intercoolers that are as much as three times the size of the smallest that would meet the specifications outlined above. The gains in performance resulting from the use of an “oversize” intercooler may, in an actual airplane, raise the critical altitude for the engines as much as 4,000 ft or more.

References

1. SKOGLUND, V. J.: Icing of Carburetor Air Induction Systems of Airplanes and Engines, *I.A.S. Jour.*, vol. 8, No. 12, October, 1941.
2. KIMBALL, L. B.: The Icing Problem in Aircraft Induction Systems, *S.A.E. Trans.*, vol. 36, 1941.
3. KITTLER, M. J.: Design of Airscoops for Aircraft Carburetors, *S.A.E. Trans.*, vol. 49, 1941.
4. MOCK, F. C.: Aircraft Carburetor Airscoops and Their Effect on Fuel Metering in Flight, *S.A.E. Trans.*, vol. 50, 1942.
5. SCHERER, P. A.: Design of Cross-flow Heat Exchangers from Tested Core Sections, *S.A.E. Trans.*, vol. 50, 1942.

CHAPTER XX

EXHAUST SYSTEMS

Aircraft-engine exhaust systems may have many different functions. It is always important that the hot exhaust gases be carried away from the engine and discharged into the air stream to prevent burning of the engine housings or of the ignition harness, etc. Since these gases contain corrosive compounds of lead, bromine, and sulfur, they should not be allowed to impinge on the aluminum skin of the fuselage, wing, or nacelle. Ducting the exhaust away from the engine also reduces the fire hazard due to fuel and oil leakage and fumes in the engine compartment. It is also desirable that the exhaust system reduce the exhaust noise and that it conceal the flame. Since they contain a considerable amount of kinetic and heat energy, the exhaust gases are a convenient source of heat for the carburetor or cabin air supply and of additional power for high-performance airplanes.

GENERAL CONSIDERATIONS

Types.—Short, or “stub,” exhaust stacks about 10 in. long can be mounted directly on the exhaust port to give an exhaust system imposing a minimum amount of back pressure on the cylinders. Their simplicity and ease of installation made them very popular for both radial and in-line engines. Light planes still use them, largely because of their light weight and low cost. Most installations of liquid-cooled V-engines in pursuit ships still make use of modified stub stacks, which act as jets and contribute considerably to the available thrust. Note the stub exhaust stacks of this type in Figs. 158 and 163.

Stub exhaust stacks on radial engines have had the disadvantage that the gas from the upper cylinders often found its way into the cockpit, where it might asphyxiate the pilot. Further, a ring of bright flames formed around the nose of single-engine airplanes to make visibility poor for night landings. These factors, coupled with the need for cabin and carburetor air heat

and other considerations, led to the almost universal adoption of the exhaust collector ring for radial engines. A typical exhaust collector ring for a radial engine is shown in Fig. 206. By collecting the exhaust gases, it makes it possible to localize the discharge to a convenient spot, and greatly simplifies any design for cabin and carburetor air heat or an exhaust turbosupercharger.

Effect of Exhaust Back Pressure.—Exhaust turbosupercharging has made the question of exhaust back pressure very impor-

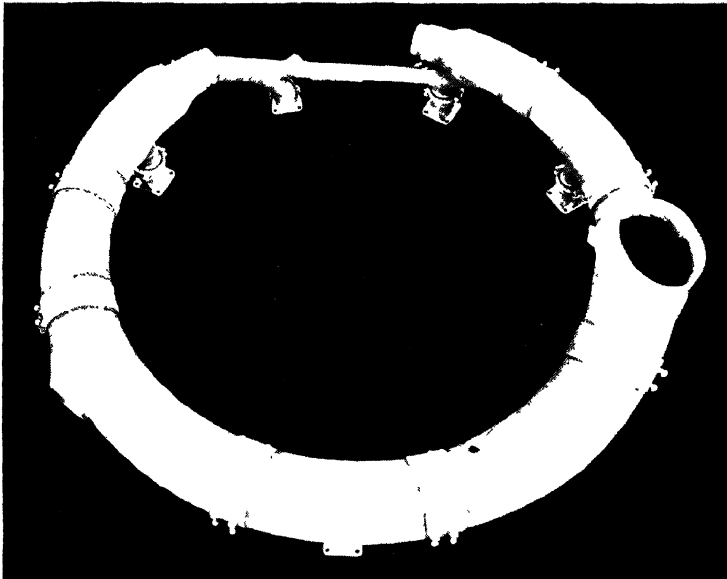

FIG. 206.—Nine-cylinder radial-engine exhaust collector ring with intensifier tubes for carburetor air heating. (*Solar Aircraft Co.*)

tant. In the four-cycle engine, exhaust back pressure has had little effect on power output. It has a negligible effect on the indicator card, for the pressure drop across the exhaust valve is greater than the “critical” during the time that the bulk of the exhaust gas leaves the cylinder. Hence, the only effect is on a part of the pumping loop of the light spring indicator card. However, it does increase somewhat the amount of residual charge remaining in the cylinder after each cycle, thus decreasing the net charge. The consequent loss of power depends on the valve timing and the breathing characteristics of the engine, but the range of values for current engines would run between

$\frac{1}{2}$ and 1 per cent loss in full-throttle power per inch of mercury increase in exhaust back pressure. Figure 207 shows the effect of exhaust back pressure on the volumetric efficiency of one type of engine over a wide range of speed and back pressure. Note that the effect of speed varies in the 2,400-rpm range owing to resonance of some sort in the induction or exhaust passages.

The effect of exhaust back pressure on the durability of engine parts depends on many factors. Generally, engine manufacturers have been opposed to exhaust back pressures of more than about 32 in. Hg abs. on the grounds that the exhaust valves would be adversely affected. No effects on cylinders, pistons,

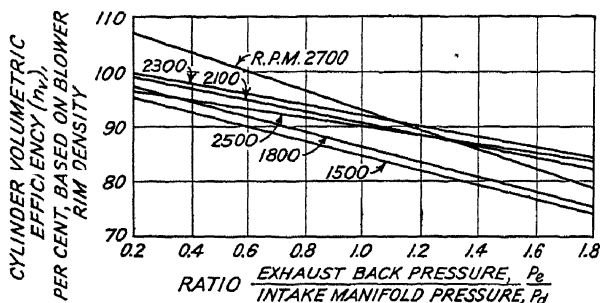

FIG. 207.—Typical volumetric-efficiency curves for a supercharged engine. (*Hersey, Jour. I.A.S., vol. 9, No. 10, 1942.*)

or rings have been noted. There seems to be no real reason why the valves should be affected appreciably by back pressures of as much as 36 or 38 in. Hg, however, since the increase in heat transfer to them due to the increased exhaust-gas density and its slightly increased temperature should be small. Such an increase in heat transfer should be considerably less than that due to the high temperatures accompanying lean mixtures, for example. Thus, with the rich mixtures used at rated and take-off power, exhaust back pressures of 36 in. Hg abs. should not be serious, especially if maintained for only a few minutes at a time during the take-off, as would normally be the case.

Exhaust Turbosuperchargers.—The above discussion indicates the reason for the fact that the exhaust turbosupercharger causes little reduction in engine power output at a given manifold pressure and no increase in specific fuel consumption. The power for the turbine is obtained by expanding the gas from the pressure at the nozzle box down to atmospheric pressure. In

effect, this process adds a "tail" to the indicator card, giving it additional area (see Fig. 208). Thus the decrease in atmospheric pressure with increasing altitude can be taken advantage of by expanding the exhaust gas through a turbine from, say, the sea-level exhaust back pressure at which the engine was designed to operate to the pressure existing at the altitude at which the

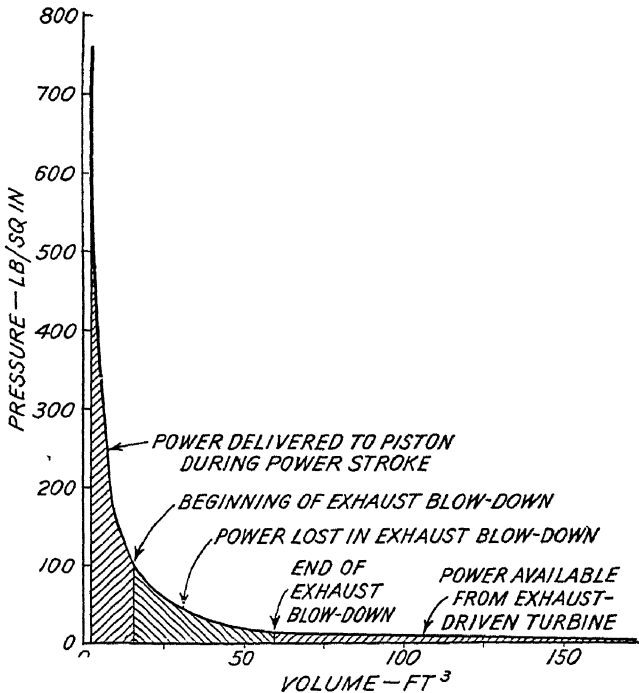

Fig. 208.—Pressure-volume diagram for the expansion of the products of combustion from the beginning of the power stroke to standard atmospheric pressure at 30,000 ft.

engine might be operating. The power available increases more rapidly with altitude than the power required for supercharging. However, very large volumes both of exhaust gas and low-density air must be handled at high altitudes. The pressure drop through the various passages increases inversely as the square of the altitude-density ratio [see Eq. (22), page 118]. Thus it becomes very difficult to provide adequate passages through the supercharger and turbine for operation at high altitudes. A few minutes' consideration will show that any small change in the efficiency of the turbine, the supercharger, or any part of the engine induc-

tion system will have a relatively large effect on the critical altitude of the engine installation. As a result, the critical altitude for full-throttle rated power depends principally on the duct design, on the size of the intercoolers, on the efficiency of the turbosupercharger unit, and on the rated turbine-wheel speed. The system is so complicated that its performance characteristics at high altitudes can be determined only by testing.

The space requirements are considerable, running on the order of 10 cu ft for the turbosupercharger unit and intercoolers for an engine rated at 1,000 hp. The incremental weight for such an installation complete including ducts and controls would run about 400 lb. The weight, and particularly the volume of the ducts would depend on their length.

Exhaust Jet Propulsion.—A considerable thrust increment can be obtained by directing the exhaust gases rearward at a high velocity. Just as in a Fourth-of-July skyrocket, the momentum thus imparted to the ejected gas causes a reaction that constitutes a thrust. Newton's third law states that for every action there is an equal and opposite reaction; the rearward acceleration of the exhaust must be accompanied by a forward-acting, or thrust, force. The magnitude of this force would be

$$\text{Force} = \left(\frac{\text{mass}}{\text{sec}} \right) \times (\text{velocity of ejection}) \quad (46)$$

The useful work accomplished by this force would be

$$\text{Useful work} = (\text{force}) \times (\text{airplane speed}) \quad (47)$$

The energy expended in the jet would be

$$\text{Kinetic energy} = \left(\frac{\text{mass/sec}}{2} \right) \times (\text{velocity of ejection})^2 \quad (48)$$

From these expressions we may obtain the efficiency, which then becomes

$$\text{Efficiency} = \frac{2(\text{airplane speed})}{(\text{velocity of ejection})} \quad (49)$$

Since in a well-designed installation the velocity of ejection will remain essentially constant at about 2,000 fps, it is evident that the efficiency will increase rapidly with airplane speed. Practi-

cally, it has been found well worth while to take advantage of this available thrust for airplanes intended to fly at speeds above 350 mph.

Take, for example, an airplane with a 1,000-hp engine and a top speed of 400 mph with propulsive efficiency of 75 per cent. To be conservative, assume that there is a 50 per cent loss in the gas exit velocity due to turbulence and the fact that only about 85 per cent leaves the cylinder at critical velocity. Since it has been found that diffusers are of little value, the maximum ejection velocity would be the critical velocity, *i.e.*, the velocity of sound in that medium. For air at 2000°R, this would be

$$V = 44.6 \sqrt{T} = 2,000 \text{ fps}$$

Applying the 50 per cent correction assumed above because of inherent losses and taking the rate of gas flow to be 7,600 lb per hr, the thrust would then be

$$\text{Thrust} = \frac{0.5 \times 7,600}{32.2 \times 3,600} 2,000 = 65.5 \text{ lb}$$

The thrust horsepower at 400 mph would be

$$400 \times \frac{1.467 \times 65.5}{550} = 70$$

The percentage increase in thrust horsepower on the basis of a propulsive efficiency of 75 per cent for the propeller would be

$$\text{Increase in thp} = \frac{70}{0.75 \times 1,000} = 9.2 \text{ per cent}$$

Of course, some of this thrust will be given by any tail pipe directing the exhaust gas flow rearward; but, even if the tail pipe is specifically designed for the purpose, only about 20 per cent of the thrust available will be obtained from most manifolds.

A number of rules must be observed in the design of an exhaust manifold for jet propulsion.¹ Not more than three cylinders firing at evenly spaced intervals may be connected to the same outlet or they will interfere with each other and cause excessive back pressure. Since no three adjacent cylinders in either single or twin-row radial engines fire at equal intervals, not more than two can be connected together. Those cylinders paired off together should be selected to give approximately equal time

intervals between exhaust impulses at any particular exit. The volume in any one stack should be kept to a minimum to prevent diffuser losses and damping of the exhaust impulse by the absorbing capacity of a large volume. This can be done only by keeping the stacks as short as possible. The upper cylinders are the only ones to present serious problems in this respect, and relatively short extensions may generally be used to direct their exhaust flow to outlets at the side. The exit opening itself may be made with a smaller cross-sectional area than the stack proper, but it should cause a back pressure of not more than 1 or 2 in. Hg.

The increase in airplane performance obtainable with exhaust jet propulsion is sufficiently great to make it more worth while than an exhaust turbosupercharger up to and somewhat above the critical altitude of the engine. This helps to make a two-stage engine-driven supercharger compare favorably with the exhaust-turbo type. The added weight and complication of the turbosupercharger are a considerable factor, of course. The power obtained from either jet propulsion or the turbosupercharger results in no increase in fuel consumption.

DESIGN DETAILS

Attachment and Support.—Exhaust collector rings supported only by the studs attaching them to the cylinder exhaust ports have been used extensively. Figure 156 shows an installation of this type. While having the considerable advantage of simplicity, especially for single-row radial engines, such collector rings have a number of disadvantages, which may justify more complicated arrangements. Engine vibration and movement induce considerable inertia stresses, which have been a chronic source of fatigue cracks in the collector rings, a condition aggravated by the notably lower strength of any metal at elevated temperatures. In twin-row radials the stresses are made more severe by the relatively little support given by the long extensions required to attach the collector ring to the front row of cylinders.

Considerable difficulty may also be encountered in laying out the cowl exit slot because of the obstruction presented by the large collector ring between the rear of the cylinders and the exit slot. This is particularly true for engines in the 2,000-hp class, for the collector ring may be 10 in. in diameter at some

points, making smooth cooling air flow through the exit virtually impossible. One way of avoiding such difficulties is to place the collector ring behind the exit slot and the inner cowling. The long stacks needed to connect the cylinders to the collector ring make some other means of support necessary. In such cases,

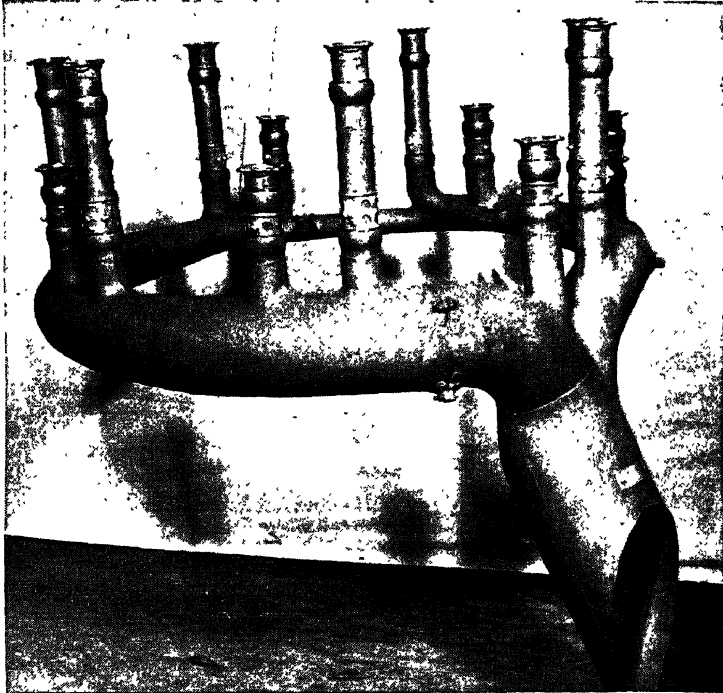

g. 209.—Exhaust manifold for a twin-row radial engine. (*Ryan Aeronautical Co.*)

the collector ring is supported from the structure of the airplane. Vibration and engine movement require that there be provision for flexibility in the stacks connecting the cylinders to the collector ring.

Figure 209 shows one type that permits a considerable amount of relative movement between the engine and the manifold. The universal joints interposed between the cylinder and the collector ring make use of a cast-iron sleeve having a spherical outer surface over which the tubular stack is expanded and permanently formed. A piston-ring-type seal is used to minimize leakage between the outer surface of the ball and the

socket. Slip between the inner surface of the cast iron and the tube within it allows axial movement to take up thermal expansion.

Size Requirements.—The gas flowing from the exhaust ports is equal in weight to the fuel and air charges flowing into the engine. Although its volume is much greater, owing principally to the higher temperature, it also has a much lower density and a higher critical velocity, with the result that the cross-sectional area of the passage required to carry off the exhaust gas is not much greater than that of the induction system. A considerable range of experience has shown that smooth well-contoured passages in an exhaust manifold should have at least 4 sq in. of cross-sectional area for every 100-hp output of the cylinders feeding any particular point. This rule is based on take-off power. If the passages are not smooth and/or there are abrupt bends, the figure must be increased somewhat.

In spite of the intermittent character of the exhaust flow from any single port, it is not desirable to decrease the cross-sectional area of points fed by a number of cylinders because such a restriction may cause an appreciable rise in back pressure. Since the exhaust gas flow, like air flow, is not far from being proportional to power output, take-off and rated power give the maximum rate of flow and hence the critical conditions.

Bends and Restrictions.—Bends in the exhaust passages should have a large radius. Restrictions should be kept to a minimum. Insofar as possible, the manifold should be symmetrical so that the exhaust back pressure will be essentially the same for all cylinders. The maximum total difference between any two cylinders should be not greater than 1.5 in. Hg, or engine "roughness" may be caused by the resulting variations in engine torque. Intensifier tubes for carburetor air heating, for example, should be incorporated in the manifold in such a way that adequate passage area is left for the exhaust and abrupt changes in section are avoided.

Thermal Expansion.—The large and abrupt temperature changes in the exhaust manifold must be provided for to prevent serious stresses. In a manifold such as that shown in Fig. 209, the universal and slip joints take care of any relative movement between it and the engine. Relative movement between the manifold and the support points can be taken care of with a

simple link type of hinge permitting movement radially but not tangentially or fore and aft. Manifolds supported directly from the cylinders, such as that in Fig. 206, must have a slip joint between each pair of cylinders so that each cylinder supports its own small section of the manifold. This arrangement has the advantage of simplicity and light weight. The installation and removal of such a collector ring are sometimes rather difficult because the warpage due to exhaust heat distorts the various sections causing poor alignment and binding at the joints. If a tail pipe is used, it must be flexibly connected to the collector ring and should be provided with its own supports.

Clearances Required.—Maintenance experience has dictated a number of requirements for accessibility. Since it is often necessary to remove one cylinder from an engine without disturbing the installation appreciably, the exhaust collector-ring connections to the cylinders should have joints permitting such removal. This is done in many collector rings by using a section only a few inches long between the exhaust port and the collector ring proper. Figure 206 shows this device. Other important requirements include adequate clearance between ignition harnesses, push-rod housings, intake pipes, and oil and fuel lines. Where the desired clearance cannot be provided, a sheet-metal shield should be placed between the exhaust manifold and the part in question, thus intercepting the radiant heat and usually preventing appreciable conduction. With a metal shield interposed, the clearance between the exhaust stack and any of the above-mentioned points may be made as little as 1 or 2 in., depending on the amount of the local cooling air flow.

Exit Openings.—The exhaust gas flow into the air stream should be such that a minimum amount of disturbance to the latter results. The turbulence caused by manifolds directing the gases radially outward has increased the drag of some installations by over 1 sq ft of equivalent flat-plate area. This, together with the thrust obtainable from the momentum of the exhaust gas, requires that the exhaust gas leave the airplane in essentially a rearward direction.

Exhaust flames may be extinguished by jet-propulsion exhaust stacks owing to the fact that the gas velocity through the exit opening is greater than the flame speed so that the flames are "blown out." Exhaust flame can also be extinguished by cool-

ing the discharge below the ignition temperature with heat exchangers before delivering it into the air stream. This effectively puts out the flame. Such systems can be made to supply heated air for wing leading-edge de-icing or to give added thrust, as indicated in connection with the Campini propulsion system (page 334).

Manifold Materials.—Although inexpensive, low-carbon steel or Amco iron has been widely used in light planes, the added cost of stainless steel or Inconel can be readily justified by decreased maintenance costs in the larger airplanes. The corrosive lead and sulfur compounds in the exhaust have virtually no effect on the latter alloys. Thus the thickness of stainless steel or Inconel may be safely reduced to as little as 0.032 in., for no allowance need be made for thickness losses due to corrosion or oxidation. Considerably greater thicknesses must be used for iron, or the service life will be short. Exhaust stacks of S.A.E. 1025 steel coated inside and out with porcelain enamel have been developed for light airplanes. These are said to be low in cost and weight and quite corrosion resistant.²

In any case, provision should be made at low points in the manifold so that water condensing from the exhaust gas when the engine is stopped will drain off easily, for such condensate picks up lead and sulfur compounds and becomes very corrosive.

References

1. SULZMAN, E. C.: Aircraft Engine Installation, *Aeronautical Eng. Rev.*, September, 1942.
2. WENDT, T. H.: Rust-proof Coatings for Manifolds, *Aero Digest*, October, 1942.
3. COLMAN, P.: Temperature Effects on Turbine Supercharger Installations, I.A.S. Annual Meeting, January, 1943.

CHAPTER XXI

FUEL SYSTEMS

There was a time when the fuel system of an airplane was as simple as that of an ordinary automobile—but that time is past. Multiengine installations, reserve fuel tanks, cross-feeds, pressure carburetors, the special problems of high-altitude flight, and maneuvers have all contributed to the complexity of present airplane fuel systems. The function of an ideal fuel system might be defined as that of delivering a continuous reliable supply of fuel to the engine at the pressure required and in whatever quantity is necessary without attention from the pilot.

VAPOR LOCK

Occurrence.—One of the most difficult problems in fuel-system design is to prevent the formation of bubbles or vapor in the fuel lines under the varying conditions of acceleration, hot weather, maneuvers, and high altitude. Most of the problems of this sort have been solved, though that of vapor lock at high altitude is still troublesome. Because of the pressure drop in the fuel lines, the fuel at the entrance to the fuel pump is ordinarily at a pressure less than atmospheric, making this critical point the one at which vapor is most likely to appear. Since the clearances of the moving parts in the fuel pump are made for a fluid of the density and viscosity of fuel, the pump loses capacity to a serious degree if supplied with vapor mixed with the fuel. This is due to high back leakage of vapor through the clearances. Further, the volume of the fuel in the vapor state is over 1,000 times the volume in the liquid state, aggravating the matter still more by reducing the weight of the fuel that is delivered. When filled with vapor the pump may become vapor-locked. When this occurs, it stops pumping and no longer gives a continuous flow of fuel to the carburetor. This, of course, causes the engines to stop completely. Even if the fuel flow to the carburetor is not stopped altogether, the carburetor cannot meter a mixture

of vapor and fuel—even small bubbles of air or vapor will seriously upset its metering characteristics. Lean mixtures, rough operation, and possibly engine stoppage will result.

This phenomenon of vapor lock of the fuel pump is most troublesome in fast high-climbing airplanes. Unless special provision is made, the fuel in the tank will give off fuel vapor and dissolved air at such a rapid rate at some altitude between 10,000 and 20,000 ft that vapor lock of the fuel pump will result.

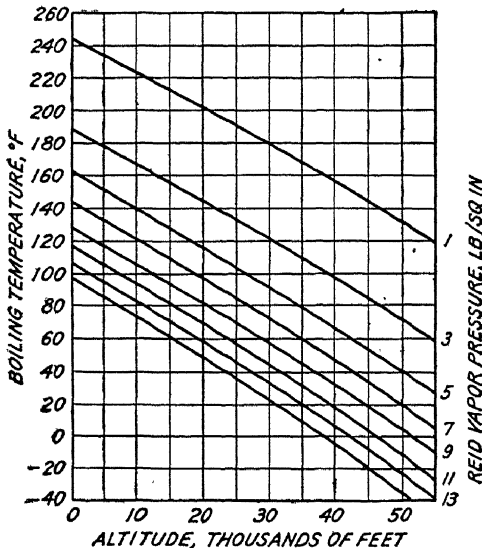

FIG. 210.—Temperatures at which boiling in the fuel tank will start at various altitudes, with typical fuels of specified Reid vapor pressure. (*Bridgeman, S.A.E. Trans., vol. 49, 1941.*)

Fuel Characteristics.—Perhaps the most important item in the problem of vapor lock is the fuel. The fuel will begin to boil at reduced pressures. Figure 210 shows the effect of altitude on the initial boiling points of a number of fuels having different Reid vapor pressures. Regular aviation gasoline has a vapor pressure of 7 psi. Not only do aviation fuels consist of many liquid hydrocarbons having boiling points ranging from 110 to 350°F, but they also contain dissolved air and light hydrocarbon gases. Just as carbonated water will effervesce and give off carbon dioxide when the pressure on it is relieved, so a reduction in the absolute pressure on the fuel will permit the air and dissolved gaseous fuel to bubble off. The temperature and pres-

sure under which the latter will occur depend somewhat upon the amount and kind of dissolved gas, but generally it occurs just below the initial boiling point. Another factor seems to be vibration—flight tests have generally shown vapor formation at lower altitudes than had been indicated by static tests on the ground. Apparently, engine and propeller vibration cause the fuel to begin to give off the dissolved gas at higher pressures than would

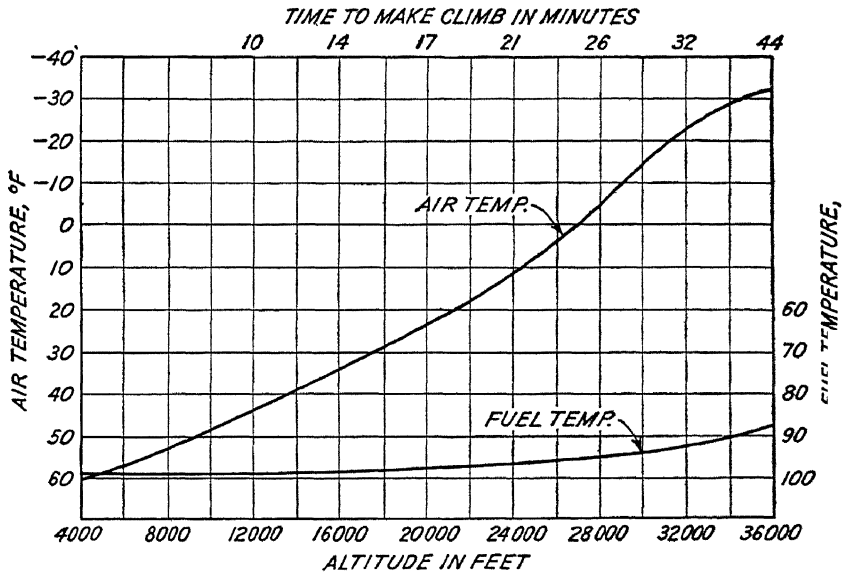

FIG. 211.—Flight test data showing the temperature of the outside air and of the fuel in the tank as plotted against altitude. (Curtis and Curtis, S.A.E. Trans., vol. 49, 1941.)

be the case if it were quiescent. This phenomenon is helpful in that it spreads the range in which the “boiling” occurs and gives a lower rate of vapor formation at the higher altitude at which actual boiling of the fuel itself begins.

Little fuel cooling occurs during a fast climb. Figure 211 shows both outside air and fuel temperatures plotted against altitude for an actual flight test. Note that the elapsed time is also plotted across the top of the sheet. In Fig. 210 it is evident that regular aviation fuel would have started to boil at about 20,000 ft if no special provisions were made.

Fuel Cooling.—Fuel cooling suggests itself as providing an answer to the problem. Fuel radiators with a circulating pump have been considered, but the added weight and drag that would

result would be considerable. Refrigeration with dry ice has been tried and found to help in some cases. It has not much effect on the liberation of dissolved air and gases, however, so that this source of difficulty must be taken care of by other means. Then, too, the method is impractical for military airplanes because of the additional servicing necessary, the large quantities of dry ice that would be required, and the difficulties of supply to military air fields in combat areas.

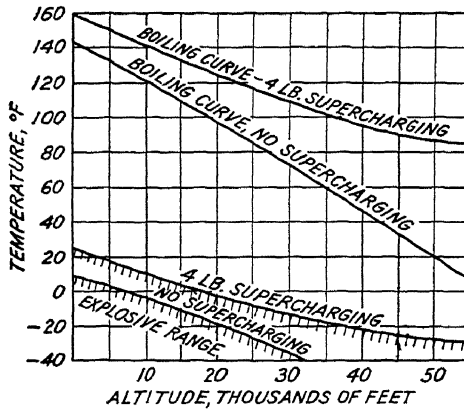

FIG. 212.—Boiling curves and explosive ranges with no supercharging and with supercharging of 4 psi on a gasoline having a vapor pressure of 7 psi. (Bridgeman, *S A.E. Trans.*, vol. 49, 1941.)

Low-volatile Fuels.—Another possible solution is to make use of a less volatile fuel. There are a number of objections to this step, however. One is that if a fuel of lower volatility is used, its starting characteristics will be poor (see Fig. 122). This objection can be met by providing a small fuel tank containing high-volatile fuel to be used only for starting, take-off, or low-altitude flying. Another objection is that if the fuel is of sufficiently low volatility really to solve the vapor-lock problem, *i.e.*, has a vapor pressure of about 1 psi, the usual carburetor will not give good fuel mixing and vaporization so that a fuel injection system would be necessary. A third objection is that of fire hazard. The low-volatile, or so-called “safety,” fuels give an explosive mixture of fuel vapor and air above the fuel in the fuel tank under most operating conditions, whereas regular aviation fuels give a mixture of fuel vapor and air that is too rich to ignite. Figures 212 and 213 show the boiling temperature of the fuel

and the temperatures giving explosive fuel-air mixtures in the tank for regular fuel and for one of low volatility, and clearly demonstrate the greater hazard of the safety fuel in this respect. As a result of these objections, a change in the fuel used has not seemed the best solution to the problem of vapor lock.

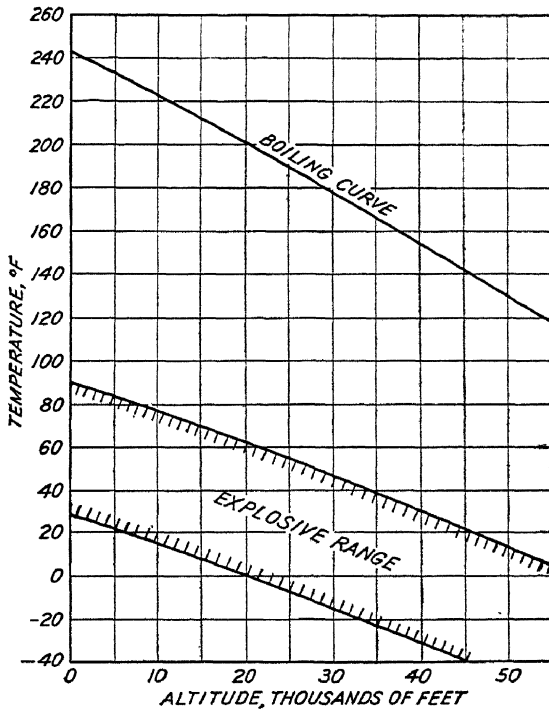

FIG. 213.—Boiling curve and explosive range for 1 psi vapor-pressure gasoline. (Brdgeman, *S.A.E. Trans.*, vol. 36, 1941.)

Tank Pressurization.—The use of a pressure relief valve in the fuel-tank vent has a number of attractive features. Not only is the boiling point raised by maintaining pressure on the fuel, but evaporation losses are greatly reduced. Since the latter may sometimes amount to as much as 10 per cent of the fuel load, this is an important consideration. Figure 212 shows the effect of a tank pressure of 4 psi above atmospheric on both the boiling point and the explosive range of a regular aviation fuel. This figure indicates that a system so equipped would be free of vapor lock even at an altitude of 40,000 ft.

The principal disadvantage of tank pressurization is increased fire hazard due to the greater tendency toward leakage. This is particularly true with respect to vulnerability to gunfire. Another objection to tank pressurization is that a sturdier and hence heavier type of tank construction is necessary.

Vapor Separators.—Vapor separators placed in the fuel line on the pressure side of the pump have proved to be effective in preventing large quantities of vapor and air from reaching the carburetor and upsetting its metering characteristics.² Separators of this sort are vented to the fuel tank, where the liquid and much of the gaseous fuel escaping from the separator vent may mix with that in the tank to keep the loss of fuel to a minimum.

Effect of Fuel-system Design.—If a fuel pump is located close to or actually in the bottom of the fuel tank, the pressure at the inlet to the fuel pump is the same as that in the tank so that boiling is scarcely more likely there than at other points in the tank. Any vapor bubbles that do form tend to float upward away from the pump, leaving the inlet continuously immersed in fuel. This arrangement has been found to be very satisfactory except that evaporation losses may be higher than if tank pressurization were used.

Careful attention to other elements in the detail design of fuel systems has been found to help greatly in reducing vapor-lock troubles. Anything that will reduce the pressure drop in the lines or keep them free of vapor will be helpful. These items will be considered in detail later.

FUEL PUMPS

Construction.—The fuel pump must supply the carburetor with the correct amount of fuel at the necessary pressure. The vane-type pump has been found to be the most satisfactory for this purpose. Figure 214 shows a typical pump in section. A pressure relief valve such as that shown is ordinarily employed to regulate the delivery pressure. It by-passes excess fuel to the inlet side of the pump. This is necessary because the vane-type pump has approximately a constant displacement. Since the engine demands for fuel vary more nearly as the cube of the rpm than linearly and since the requirements at any given rpm vary widely, the pump is built to have a capacity greater than the

maximum demand, and a relief valve is provided to by-pass the excess.

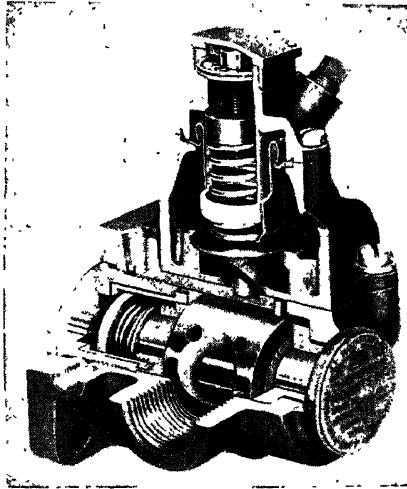

FIG. 214.—Vane-type engine-driven fuel pump. (*Thomson Products, Inc.*)

An auxiliary hand pump must be provided to prime the carburetor for starting. It will also serve as a stand-by pump for

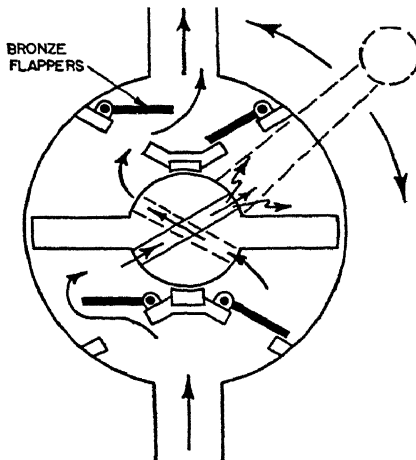

FIG. 215.—Schematic diagram of a wobble pump. (*Civil Aeronautics Administration.*)

emergency operation in the event of a fuel-pump failure. Wobble pumps such as that shown in Fig. 215 are generally used for this purpose.

Types of Drive.—For simplicity, light weight, and reliability, it is desirable to use a fuel pump driven by and mounted directly on the engine. The likelihood of vapor lock may be reduced by placing the fuel pump closer to the tank, in which case it may be driven by a flexible shaft. If the location of the pump is remote from the engine, it may be driven by an electric or a hydraulic motor.

An electrically driven fuel pump of the centrifugal type that may be located directly beneath or installed in the bottom of the fuel tank has many advantages.^{3,4} Although employed primarily as booster pumps to push fuel through the lines to the pressure pump and in that way prevent vapor lock, such units may also be capable of providing sufficient pressure at the carburetor to make a hand pump unnecessary either for starting or for standby operation. Since the starter throws such a heavy load on the battery, a wobble pump is usually provided with the booster pump to ensure an adequate fuel supply for starting.

FUEL TANKS

Fuel-tank location presents many debatable problems. In most cases, the final decision is determined by expediency—the most convenient location is used. However, it should be remembered that fuel tanks constitute the most serious fire hazard in the airplane. In transport airplanes, it has been considered best to place the tanks in the wings well away from the fuselage, pilot, and passengers. This has the additional advantage of giving more space in the fuselage and, in multiengine ships, places the tanks closer to the engines. Further, this location is near the center of lift so that the balance of the airplane is not seriously affected as the fuel is consumed on a long flight.

Construction.—In commercial and training airplanes and in peacetime military planes, gas tanks of sheet aluminum are light, corrosion resistant, durable, and relatively inexpensive. To ensure tightness, all seams are usually welded. Sometimes, to save weight, the tanks are made integral with the wing structure, in which case they are referred to as *integral fuel tanks*. In general, however, tanks having large flat bottoms are avoided because of the difficulty in using up the last portion of the gasoline, especially in maneuvers. Further, large flat surfaces respond readily to vibration, acting as diaphragms. The

government requires that representative specimens of all metal fuel tanks must pass an endurance test on a special vibrating test machine as part of the certification regulations.

Self-sealing, or "bulletproof," gas tanks were developed during the First World War; but since they were heavy and cumbersome, they were abandoned during the years of peace. Leakage and the fire hazard that accompanies it were prevented by the use of several layers of material, one of which swelled rapidly when contacted by gasoline and thus filled the bullet holes. This type was revived and further developed for the Second World War. A typical German example had an inner fiber tank, an intermediate layer of $\frac{1}{8}$ in. of buckskin, and an outer layer of natural rubber. The latter would swell when contacted by gasoline and fill any bullet holes. American rubber companies have worked on the problem and have developed good self-sealing tanks. One concern has developed a tank having five layers. An outer shell provides support and mechanical strength. A layer of steer hide or other material resistant to tearing comes next to keep the hole from becoming larger than the bullet (aluminum tends to tear and leave large, gaping holes). A layer of a synthetic rubber that swells slowly when contacted by gasoline acts as a permanent seal to fill any hole that may be formed. Since this substance is slow to act, a layer of sponge rubber in which the air cells are noncommunicating serves to give a temporary but very quick acting seal. A neoprene lining keeps the gasoline from coming in contact with the sealing materials. Since gasoline tends to dissolve in neoprene, the interior of the tank is coated with a special gasoline-resistant resin.

A third type of tank construction has been referred to as *crash proof*. Since gasoline fires accompany a large percentage of crashes, it is desirable to make use of a tank that will not rupture under the shock of a moderate crash. One make that has been used successfully employs a neoprene-impregnated fabric cell of light construction. A flexible, shockproof, yet reasonably light construction is obtained by allowing the airplane structure to carry all the loads due to the weight of the fuel. Cell compartments are built like integral fuel tanks, except that no sealing of the joints is necessary.

A comparison of the weight addition chargeable to the various types of fuel tank is interesting. The integral type can be built

into the airplane with the smallest increase in weight, *viz.*, about $\frac{1}{4}$ lb per gal. Conventional sheet-aluminum tanks generally weigh $\frac{3}{4}$ lb per gal for small tanks to $\frac{3}{8}$ lb per gal of capacity for 100-gal and larger tanks. Bullet-sealing tanks weigh between 0.7 and 1.5 lb per gal. The crash-proof tank described weighs about 1.0 lb per gal. The importance of the weight consideration in long-range airplanes may be seen from an estimate based on the above approximate values—a 35-ton long-range flying boat with a fuel-tank capacity of 4,000 gal would be able to carry about 4,000 lb less pay load if fitted with bullet-sealing instead of integral-type tanks. This would seriously reduce either the pay-load capacity or the cruising range.

Regardless of the outer construction, baffles are very often installed in the larger tanks to localize the movement of the fuel during maneuvers, etc. These may be constructed so that they will collapse and absorb the shock of a crash and prevent rupture of the tank. A sump, located at the lowest point in the tank when the airplane is at rest on the ground, is used to collect any water or sediment that may enter with the fuel. It is important that there be no other low spots in aluminum tanks in which water can collect, for corrosion is likely to occur. The drain plug in this sump in aluminum tanks is usually fitted with a corrosion-resisting cartridge to prevent water and acids in the fuel from attacking the aluminum. The filler pipe should be so constructed that it is impossible for fuel to be siphoned from the tank or for the tank to be filled to more than 97 per cent of its volume. That is, an expansion space of 3 per cent must be provided. A vent to permit air and vapor to pass from the tank must be installed to communicate with this expansion space. Such vents must have ample capacity for rapid climbs unless pressurization of the tank is used.

Considerably more expansion space is required with bullet-sealing tanks. One of the biggest problems in military-airplane tank design is surge pressure caused by the impact of bullets. There have been cases in which full fuel tanks surrounded by rigid walls that allowed no expansion have been completely disintegrated with one shot. Such instantaneous pressures are of course hard to evaluate, but indications are they may be as high as 800 psi. Expansion space in the tank and for the tank is vitally necessary.

LINES, FITTINGS, AND GAUGES

Line Size.—The plumbing used in a fuel system must be absolutely dependable. The fuel lines should be large enough in diameter to prevent serious pressure drops during high-power operation. A good rule is that the line velocities should not exceed 130 fpm. Similarly, all valves and fittings should have passage areas at least equal to those of the lines and should be free of sharp corners and abrupt changes in section which might cause turbulence and vapor formation, with the attendant vapor-lock possibilities. Some notion of the pressure loss occurring in fittings may be obtained from the fact that one type of standard elbow gives a loss equivalent to 40 in. of straight pipe. A 6-in.-radius 90-deg bend in the same pipe causes an increase in pressure drop equivalent to only 2.6 in. of straight pipe.¹ This shows how much more desirable a correctly made bend is as compared with a fitting.

Exact data on pressure drop in lines and fittings are available and makes accurate estimation of this item relatively simple. The C.F.R. committee on aviation vapor lock has conducted extensive investigations on the pressure drop through all types of elements used in fuel systems.¹ It was found that the pressure drop across any unit or collection of units can be expressed by the following equation:

$$\Delta P = CW^{1.75} \quad (50)$$

where ΔP = pressure drop, psi.

W = fuel flow, lb per hr.

C = a constant depending on the unit and on the characteristics of the fuel.

The experimental values for the constant C for tubing and sections of uniform bore were found to check closely with theoretically derived values. The equation used is

$$C = \frac{BL}{d^{4.75}} \quad (51)$$

where d = inside diameter, in.

L = length, in.

B = constant.

Experimental data indicated that discontinuities and restrictions gave a value for C of

$$C = B \quad (52)$$

Theory indicates that the constant B is directly proportional to the ratio $\mu^{0.25}/\delta$ where μ is the absolute viscosity of the fuel in poises and δ is its density in grams per cubic centimeter. A survey disclosed that aviation fuels all have a value within a few per cent of 0.350 for this constant.

The value of the constant B was determined for many types of fitting. Based on $\mu^{0.25}/\delta = 0.350$, some of the more important are as follows:

	$B \times 10^8$
Tubing and sections of uniform bore:	0.099
Bends of uniform radius R (in.)	
through the arc θ (deg):	$\frac{1.00 \times \theta}{R \times 90}$
Sharp 45-deg-angle disturbance:	1.05
Sharp 90-deg-angle disturbance:	4.29

Strainers.—Screens are ordinarily placed at all inlets and outlets of the fuel tank, and a strainer should be located at the lowest point in the fuel line between the tank and the carburetor. These should be easily accessible and removable for cleaning.

Gauges.—A fuel pressure gauge is required for most carburetors to give the fuel pressure at the carburetor inlet connection. A fuel quantity gauge should also be provided for each tank. Fuel flowmeters are desirable, but it has proved difficult to build one that is light in weight, not too complicated, and yet accurate in all normal flight attitudes.

Valves.—Selector valves are necessary to supply the engine from any one of the fuel tanks, as well as to make it possible to cut off the fuel completely. The most commonly used type of selector valve consists of a hollow plug that may be rotated in a cork seat so that an opening in one side of the plug may be indexed to any of several openings around the periphery of the valve. Fuel may flow in through one of the latter openings and out through one end of the plug into the line to the engine. Poppet-type fuel valves have also been used successfully and

have been found to possess a number of desirable features, including more positive seating and lower operating forces.

Fire-hazard Limitations.—Fire hazard is an important consideration. From this standpoint, it is desirable that a minimum amount of the fuel system should be under pressure so that, if a leak does occur, the highly inflammable fuel will not be sprayed out into the airplane. For the same reason, it is highly desirable that no fuel lines be run into the cockpit. Remote-reading electrical fuel pressure gauges, for example, are better from this standpoint than the conventional Bourdon tube gauge.

TYPICAL FUEL SYSTEMS

Single-engine Installations.—Although many arrangements are possible, single-engine airplanes generally have simple fuel

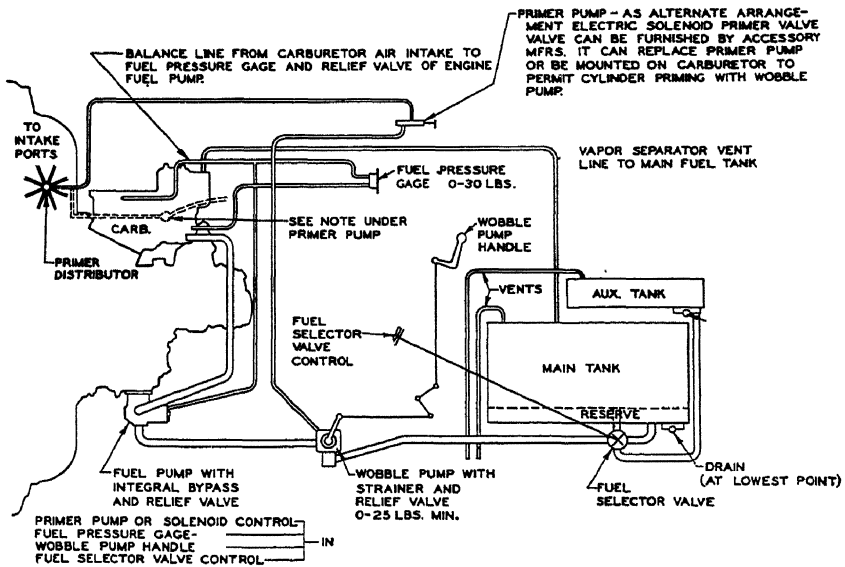

Fig. 216.—Schematic diagram of simple fuel system with direct engine-driven pump. (Pratt and Whitney Aircraft.)

systems such as that shown in Fig. 216. The double-outlet arrangement is not employed in all airplanes. A pipe extending up to the middle of the tank may be used with the double-outlet arrangement, in which case it serves to permit a continuous supply of fuel in all maneuvers if the tank is nearly full. In the figure shown the double outlet serves to provide a positive

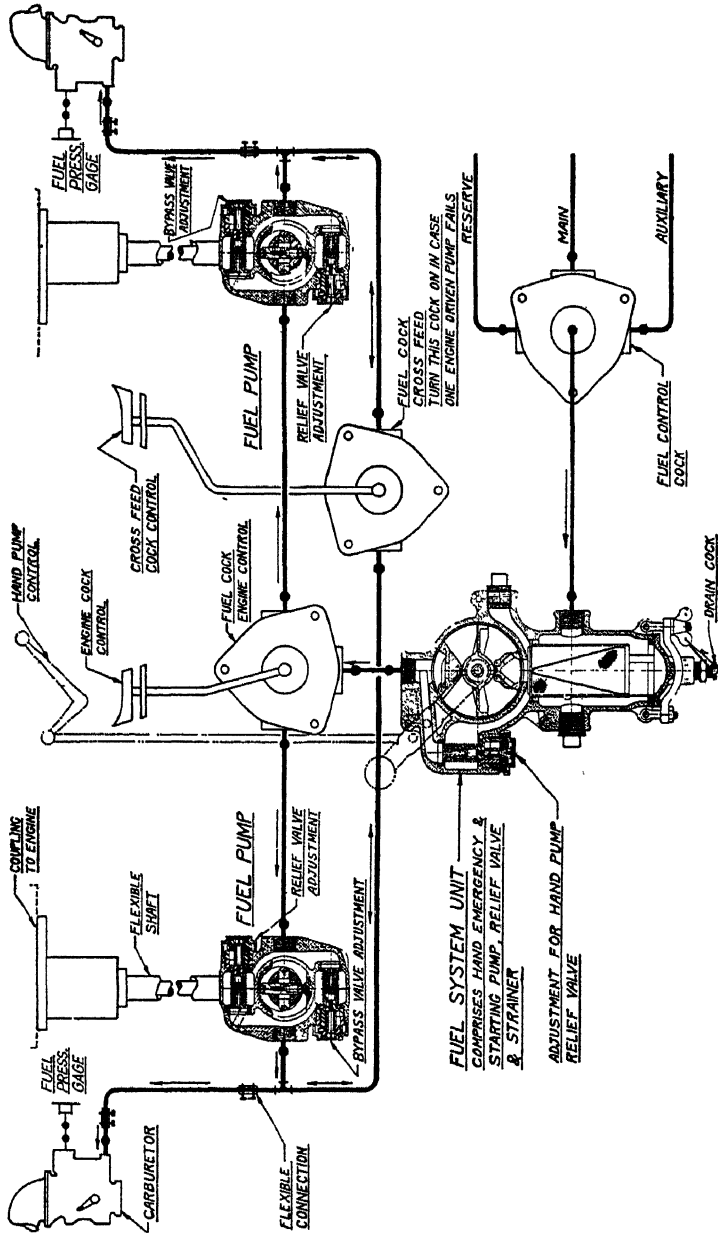

Fig. 217.—Twin-engine fuel-system with remote-driven pumps, cross-feed, and a single hand pump for starting and emergency operation. (Romec Pump Co.)

warning that only a limited amount of fuel remains in the tank. More than one tank may be connected to the selector valve. In all cases, the selector valve will have a "shutoff" position. If a selector valve is not used, a shutoff valve of some sort is provided. Note that the hand pump and strainer are combined in one unit, which is located at the lowest point in the system. This is common practice.

Multiengine Installations.—Multiengine installations with reserve supply tanks, cross-feed lines for emergency operation, etc., are considerably more complex than those described in the preceding section. To simplify matters for the pilot, the valve-control arrangement should be simple, positive, and quick acting. In the event of an engine failure, it is desirable that it be possible to feed any combination of engines from any of the fuel tanks in a multiengine airplane. Practical limitations and the need for simplicity together with excellent engine service records have permitted some modifications, and these ideal requirements are not always met. A relatively simple twin-engine fuel system with remote-driven pumps, cross-feed, and a single hand pump for starting and emergency operation is shown in Fig. 217. The requirements for different applications vary so widely that it would be confusing to try to cover them all. The Army, the Navy, the civil aviation authorities, the engine manufacturers, and the air lines have each established requirements and recommended practices for equipment with which they are concerned. Specific information should be obtained from the organization that will ultimately approve the installation.

References

1. BRIDGEMAN, O. C.: CFR Committee Report on Aviation Vapor Lock Investigation, *S.A.E. Trans.*, vol. 49, 1941.
2. SCUDDER, N. F.: Flight Test Research on the Problem of Vapor Lock, *I.A.S. Jour.*, vol. 6, No. 2, December, 1938.
3. CURTIS, W. H., and R. R. CURTIS: New High Altitude Fuel System for Aircraft, *S.A.E. Trans.*, vol. 49, 1941.
4. CURTIS, W. H., and R. R. CURTIS: Fuel Feed at High Altitude, *S.A.E. Trans.*, vol. 50, 1942.

CHAPTER XXII

OIL SYSTEMS

Although automobile and light-plane engines generally operate satisfactorily with oil systems completely enclosed in the engine, aircraft engines of 200 hp and more require external systems with provision for cooling the oil. Such oil cooling would benefit even the smaller engines but has been avoided in the interests of simplicity. Another reason for the use of an external system is that the quantity of oil that is burned or lost through leakage generally runs considerably higher for the larger engines than could be reasonably carried in the crankcase. It was shown in the chapter on Lubrication, Oil Flow, and Scavenging that the supply of oil to the engine bearing surfaces must not be interrupted under any circumstances, for complete failure of vital engine parts would certainly result in a matter of seconds. Thus the principal function of the oil system is to supply the engine at all times with the oil it needs, and to maintain that oil at the proper temperature. It is also desirable that the oil system contain special provisions to permit easy starting and quick warm up in cold weather. The character of these problems and the methods used to meet them in the design of oil systems are covered in this chapter.

ARRANGEMENT OF TANK, COOLER, AND LINES

Simple System.—The simplest type of oil system makes use of only a tank, an oil cooler, and the plumbing required to connect them. In the interests of simplicity, light weight, and low cost, as well as to keep the lines short and the pressure drop in them to a minimum, both the oil tank and the cooler are usually placed as close to the engine as possible. The oil level in the tank should be somewhat above the engine oil pump to avoid possible air locking of the pump on starting; but it should not be too high, or the resulting pressure may force oil through the check valve into the engine and flood the latter.

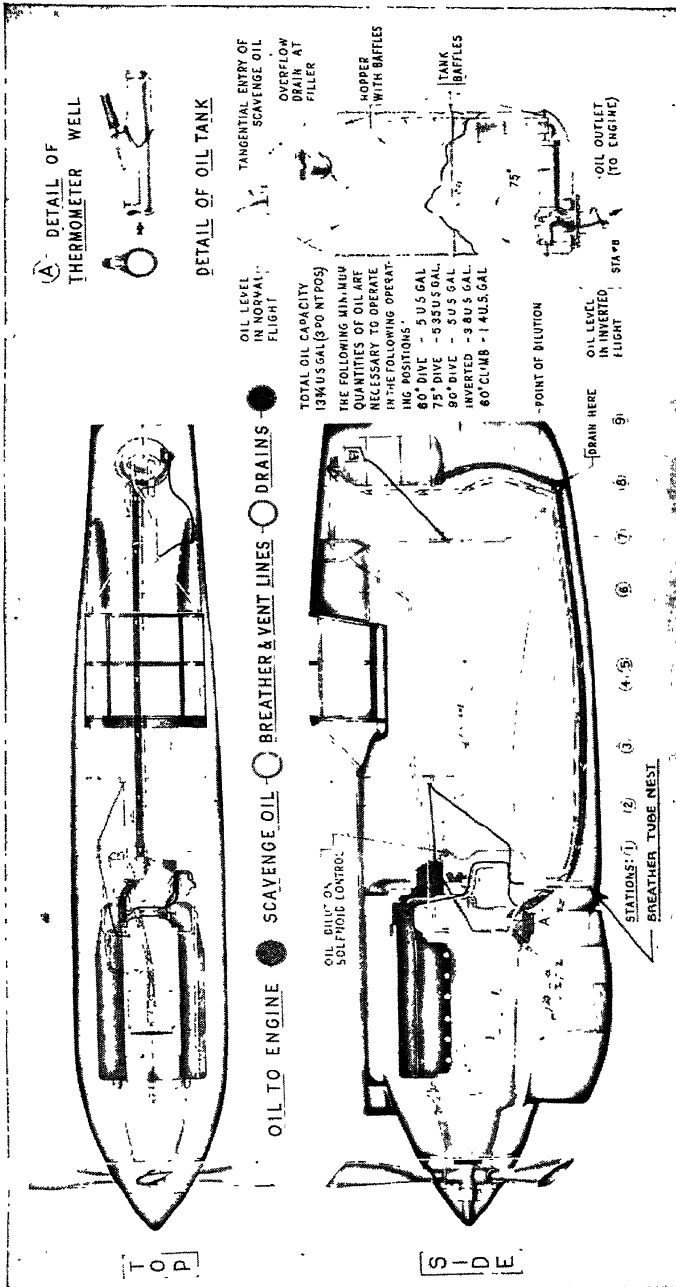

Fig. 218.—Oil system of a Curtiss P-40 fighter. (Allison Division, General Motors Corp.)

Systems for the Larger Engines.—Since the problems of lubrication, scavenging, and breathing are interrelated within the engine, it is not surprising to find them all involved in the oil system. The engine breather outlets from the crankcases are usually vented to the top of the oil tank. A common vent to the atmosphere serves both the tank and the engine. Figure 218 shows the oil system for a pursuit ship in which the oil tank has been placed much farther from the engine than is usual. Notice that it is much more complex than the simple system described above. The details of the special control equipment, etc., will be fully covered later in this chapter.

Cooler Location.—The principles developed in connection with ethylene glycol radiators apply equally well to oil coolers. A ducted radiator with its air inlet located in a region of high pressure presents the least drag and gives the best cooling. Some radiators are installed directly beneath the engine, as shown in Fig. 218, while others may be installed in the wings. These may tap the high-pressure region at the leading edge of the wing for cooling air (see Fig. 165). Other locations are possible and may be aerodynamically desirable in some cases.

OIL COOLERS

Construction.—Oil coolers of the “barrel” type similar to prestone radiators are most commonly used (see Fig. 219). These consist of short lengths of extruded copper tubing, the ends of which have been expanded and formed into a hexagonal shape to make possible “nesting” of the tubes and sealing at the ends. The air flows through the inside of the tubes to cool the oil flowing up over baffles between them. Shutters should be supplied in the cooling-air exit duct to control the air flow, both to reduce the cooling drag at high speed and to provide control over the oil temperature.

Cooler Size.—The oil-cooler size depends on both the engine oil flow and the heat rejection to the oil. In a given engine, the latter factor falls off with an increase in “oil-in” temperature, as was shown previously (see Fig. 137). The reduction in cooling-air flow requirements and drag obtainable by going to higher temperature differences between the cooling air and the heat-transfer surfaces have been demonstrated in previous chapters. To take advantage of these benefits, the maximum

normal oil-in temperature of the later types of engine has been raised to about 185°F instead of the 140°F common until about 1935. For take-off and climb, about 200°F is now considered allowable. This imposes much more severe conditions on the oil, but it has permitted reductions in oil-cooler weight and drag of the order of 50 per cent due both to the decrease in heat rejection from the engine to the oil (see Fig. 137) and to the greatly increased rate of heat transfer to the cooling air.

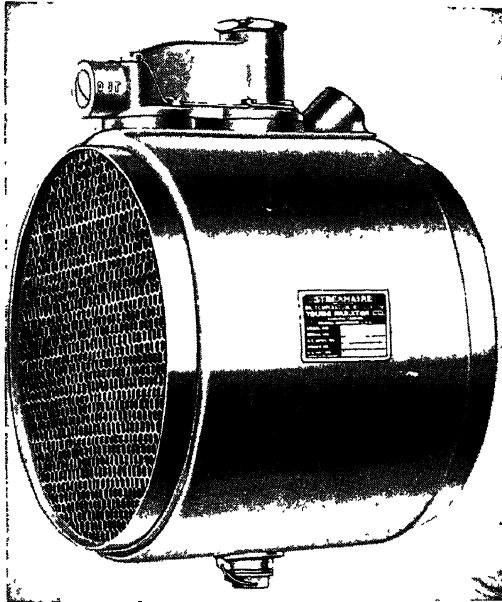

FIG. 219.—Tubular oil radiator. (*Young Radiator Co.*)

The heat rejection that must be provided for is given in the engine specifications. As was pointed out in the chapter on Lubrication, Oil Flow, and Scavenging, this is a difficult figure to arrive at because it depends so much upon the flow conditions and the temperature of the cooling air passing over the engine; the condition of the engine so far as wear, oil flow, etc., is concerned; and on other less tangible factors. As a result, it may be desirable in some cases to provide greater oil-radiator capacity than would be required by the engine manufacturer's specifications. As in the cooling of the engine cylinders, rated-power climb usually represents the critical design condition. That is, maximum heat rejection with a minimum available cooling-air

pressure drop across the radiator occurs under the low-air-speed high-engine-power-output conditions prevailing in a climb. On the basis of data (see Table XI, page 455) and curves obtainable from oil-cooler manufacturers, it is possible to select a unit that will take care of the heat rejection anticipated with the highest cooling air temperatures and with the cooling-air pressure drop available. These charts are similar to those used for ethylene glycol radiators and for intercoolers.

Temperature Regulation.—The problem of oil temperature control may really be divided into two phases. The first occurs during the engine warm up and involves a control that will permit the oil to by-pass the cooler until the desired oil-in temperature has been reached. The second phase centers on maintaining the oil-in temperature constant after the engine and oil have been warmed up.

Automatic temperature control is practically essential for the warm-up period. This may be provided in the form of a thermostatically operated valve that allows the oil to by-pass the cooler when too cold, or it may be in the form of an orifice and pressure control system that responds to changes in oil viscosity, operating a by-pass valve in the same manner as the thermostatically controlled system. The latter arrangement may also be used for the second phase of control by providing automatic shutter operation to control the cooling air flow. If a viscosity type of control is used, the pressure differential across the viscosity-sensitive restriction may be used directly to actuate a servo piston, which will operate the cooling air shutters.

A pressure relief valve by-passing the cooler should be provided in the oil scavenge line to prevent the high scavenge pressure following starts in cold weather from bursting the cooler. Provision of this sort can be easily incorporated in the viscosity-type control system, for the scavenge pressure is the only element affecting its operation.

Certain unusual difficulties have arisen in connection with oil temperature control when the air flow through the cooler has been regulated by the pilot. In very cold weather, the oil in the cooler tends to congeal. This forces the bulk of the oil to by-pass the cooler and results in higher oil-in temperatures. The first reaction of the pilot, of course, is to allow more cooling air to flow, which makes the oil congeal still more in the core. The

only way to clear up such a condition is to shut off the cooling air flow to allow the core to thaw out. An automatic shutter control operating on the basis of the pressure drop across the cooler would eliminate this difficulty.

OIL TANKS

Construction.—The requirements for oil tanks are similar to those for fuel tanks from the standpoint of strength, vibration, and fatigue resistance, and they must pass similar vibration tests. Aluminum, stainless steel, and copper alloys have been used, aluminum having a distinct weight advantage. Torch-welded tanks of 3S or of 52S aluminum alloy have been favored because the weldability and corrosion resistance are good, the weight and fabrication cost low, and their service record is excellent. Since the synthetic rubbers used in self-sealing fuel tanks are adversely affected by long exposures to hot oil, self-sealing oil tanks are generally made by placing the layers of sealing material on the outside of the regular aluminum tank. ↷

Tanks are usually rounded—often oval—in shape. Their longest dimension should be placed vertically if possible, to help keep the outlet from the tank to the engine submerged in oil in all probable attitudes of flight, including climbs, dives, and sideslips. Wide, shallow tanks obviously permit “sloshing” of the oil under part-full conditions and allow air to enter the engine oil supply line. The filler pipe should be so located that it is impossible to fill the tank completely with the airplane resting in its normal position on the ground, for an air space for expansion is essential. This provides for the effects of heating as well as the inflating effect of air and gas bubbles in the oil returned to the tank from the oil pump. Water in the oil will bring about an excessive formation of such bubbles, causing foaming, and possibly overflow from the tank after the expansion space has been filled.

Capacity.—The usual practice has been to provide a single oil tank of sufficient capacity to meet all combinations of conditions. The necessary capacity of this tank depends on four factors. (1) Enough oil must be provided to keep the outlet covered in all specified flight altitudes. (2) An additional amount, sufficient to provide for oil consumption on the basis that the engine will burn 1 lb of oil for every 20 to 30 lb of fuel, is evidently

essential. In the large engines on long-range bombers, the oil consumption may be as much as 400 lb, or over 50 gal per engine, on a single flight. (3) Room for a quantity of oil sufficient to fill the system should be provided. This oil is called "residual oil." (4) An expansion space equal to about 10 per cent of the capacity of the system is also necessary. This space need not exceed 5 gal, nor should it be less than 1 gal.

Thus, the required tank capacity is the sum of four items, *viz.*, the minimum amount for safe operation, the maximum oil consumption to be expected on long-range flights, the residual oil, and provision for expansion amounting to 10 per cent of the total of the other three. If a hydromatic propeller is used, the space left for expansion should be increased by 1 gal, plus the capacity of the "feathering oil" tank. The exact values for the various items may be determined from the engine manufacturer's recommendations or from the customer's specifications.

Warm-up Compartments.—To aid in starting and quick warm ups, it is possible to make use of a *warm-up compartment*, or *hopper*, in the oil tank. This hopper is generally in the form of a long cylinder extending vertically from the outlet at the bottom of the tank to the inlet at the top. Depending on the amount of engine oil flow, the capacity of the hopper runs from 1 to 3 gal. Small passages sufficient to provide for overflow at the top and for addition of oil from the tank proper at the bottom are provided to permit flow from the tank to the hopper when necessary. There is no flow from the one to the other except to supply new oil to the hopper for replacement of that consumed. In cold weather in particular, this is advantageous because the oil in the hopper becomes warm in a fraction of the time that would otherwise be required for the entire tank. The design details are such that sludge tends to be deposited in a sump at the base of the hopper. This sump can be easily removed for cleaning.

Figure 218 shows a hopper-type oil tank. As indicated at the top of the tank, the oil return line from the engine should enter the tank in such a manner that the oil is discharged tangentially against the wall of the hopper. If the latter arrangement is used, the spiral path of the oil stream down the wall of the hopper results in a centrifuging action. This helps greatly to separate the air and vapor bubbles from the oil and prevents

foaming. It also gives a smooth entrance of the return oil into the pool in the hopper well. If it were simply dumped into the tank, air would be entrained by the dumping action and bubbles would be carried right on down through to the outlet and thence into the oil inlet line.

The hopper-type oil tank has a number of disadvantages, the most important of which is that the oil flowing to the engine becomes "dirty" much faster than would otherwise be the case. All the sludge and asphaltenes formed as the engine operates are concentrated in a small amount of oil and kept circulating through the system. Much of this material is deposited in the sump provided for that purpose in the bottom of the tank. A considerable amount is also deposited in the engine, the cooler, and the lines. The engine is thus supplied with oil in the worst possible condition during practically all the time between overhauls. However, the many advantages of the hopper-type system have been such that the oil refiners have developed oils that give satisfactory service even under these adverse conditions.

OIL LINES, VENTS, AND DRAINS

Line Materials and Connections.—Oil lines have been made of brass and copper, but anodized 52S aluminum or flexible synthetic materials have been more commonly used since 1935. Joints in metal lines may be soldered, brazed, or made with neoprene or other synthetic rubber hose that is relatively unaffected by oil. The latter type is particularly desirable because of its flexibility, which helps to isolate vibration, and is widely used. When this type of connection is used, the hose may be firmly held in place by one, or sometimes two, hose clamps on each side of the gap between the pipes (see Fig. 160). A bead formed near the end of each pipe may be used to help hold the connection together. Flexible lines of synthetic materials are somewhat heavier than metal lines of the same size, but their flexibility simplifies the installation. Such lines make use of metal fittings swaged in place at the ends to give a permanent assembly. Bullet-sealing oil lines of synthetic materials are also available and are in use in military aircraft.

It is of the utmost importance that there be no air leaks in the oil line from the tank to the inlet side of the engine oil pump; for any such leaks cause both a considerable loss in pump capacity

and the delivery of air instead of oil to the engine oil passages and bearings, which gives a very dangerous condition. A symptom of such leaks is irregularly fluctuating oil pressure. The fluctuations may be 2 or 3 to 30 or 40 psi. Air leakage of this sort may occur only under certain conditions in which the suction in the oil-in line is particularly great. For this reason, the oil lines should be of adequate diameter and should employ a minimum number of fittings.

The pressure drop in the oil-in line may be sufficient to cause partial "air locking" of the oil pump. That is, air leakage back through the pump clearances may become so great with high suctions at the pump inlet that the gears will simply spin and will pump little or no oil. This condition will arise whenever the inlet suction becomes large compared with atmospheric pressure. It may occur during flight at high altitudes or before the oil has been adequately warmed after a start in cold weather.

The pressure drop through the oil lines may be calculated on the basis of viscous-flow conditions. The ideal formula of classic hydrodynamics holds very closely, *viz.*,

$$\Delta P = \frac{18.8}{\delta d^4} \quad (53)$$

where ΔP = pressure drop, psi.

μ = viscosity, lb sec/sq in.

l = line length, in.

W = oil flow, lb per min.

d = internal diameter of line, in.

δ = specific weight, lb/cu in.

Values for the viscosity of a typical aircraft-engine oil can be obtained from Fig. 250.

An approximate formula which holds with little error for aircraft-engine oils is given by

$$\Delta P = \frac{0.58 \times 10^{-6} Wl}{\delta d^4} \text{ (S.U.S.)}$$

where the notation is as in Eq. (53) except that the oil viscosity is in Saybolt universal seconds (S.U.S.), replacing the term μ/δ .

Oil lines should be so inclined and located that they may be easily drained through fittings provided for the purpose. This

is particularly necessary for cold-weather operation. Unless the oil is drained from the lines, it may congeal there and stop all flow.

Vents.—Oil tanks are usually open to the atmosphere through two vents so that one is always clear. Sometimes the tank is vented to the rear section of the engine so that vapor and gases may flow out through the regular crankcase breather. In other cases, the engine may be vented to the tank, and a common vent made to the atmosphere. The latter should be so placed that water cannot collect and freeze in it. Its exit should be clearly visible from the cockpit in order that engine breathing difficulties, as evidenced by considerable amounts of oil or vapor leaving the vent, can be easily noticed.

Drains.—A cup, usually called a “scupper,” may be provided around the tank filler opening to catch any oil spilled in the filling process. A drain line should be provided from this cup to carry off the oil caught in this manner.

Valves.—If the engine were started with a valve in the supply line closed, it would be ruined if allowed to run for more than a minute or so. Since they are really not needed, valves other than drain cocks should never be used.

PROVISIONS FOR QUICK STARTING AND SHORT WARM-UP

Warm-up Stoves.—A hopper in the oil tank and a cooler bypass valve help to expedite starting and warm up, but they are inadequate in cold weather. Since aircraft engines must use heavy oil because of high bearing loads and since the pour point of this oil runs between 10 and 15°F, it is evident that the oil will congeal in the engine at temperatures below 10°F. When this occurs, it becomes so difficult to turn the engine over that starting is practically out of the question. The whole engine may be covered with a hood and warmed with a stove. The oil drained from the engine sump, the tank, the cooler, and the lines immediately after the preceding flight can be warmed separately in such cases and poured hot into the tank.

Oil-dilution Systems.—The considerable time required to warm an engine as outlined above may be avoided by injecting gasoline into the oil-in line just before stopping.¹ The gasoline dissolves in the oil and considerably lowers both the viscosity and the pour point of the oil. By this means, it is possible in an emergency to start an engine at temperatures near 0°F and take

off immediately. Although this practice is hard on the engine, it may be followed in military work. Its value in an airplane such as an interceptor fighter is inestimable and needs no explanation.

Figure 218 shows a typical oil-dilution system including the electric solenoid-operated valve, which permits fuel to flow from the pressure line ahead of the carburetor into the oil-in line. The solenoid valve is controlled by a button in the cockpit that may be pushed for the proper number of seconds just before stopping the engine. As the engine warms up when next started, most of the gasoline then vaporizes out of the oil and leaves it at its original viscosity.

Immersion Heaters.—For certain types of service in which quick starting and short warm-up periods are essential, the oil in the tank may be preheated with an electric immersion-type heater. The electric current may be supplied from some convenient source other than the airplane itself to avoid running down its already heavily loaded* batteries. Immersion heaters may also be used to expedite the warm up, in which case the current is supplied from the generator on the engine while the engine idles.

MISCELLANEOUS DEVICES AND FEATURES

Gauges.—An oil temperature thermometer and an oil pressure gauge are necessary as standard equipment in all engine installations. The former is usually located in the oil supply line near the inlet to the engine. The latter is connected to the pressure tap provided on the engine. In a few cases, additional pressure gauges may be necessary. These include the pressure gauges needed for torque meters and two-speed supercharger-clutch control pressures. Oil quantity gauges are required in the tanks of the larger multiengine airplanes.

Filters.—Various oil filters, centrifuges, and other devices have been used in an effort to keep the oil clean. The rate at which sludge forms, however, is so rapid that filters clog quickly—often in as little as 8 hr of operation. The penalties attached to failure of the engine oil supply due to an obstruction in the system are so much greater than the benefits to be derived from cleaner oil that filters have not been favored. The added weight and complication to the system have been other objections to

their use. Generally, no strainers or filters except those incorporated in the engine itself are used.

Special Devices for Maneuvers.—The engine oil system will not, as a rule, permit operation in an upside-down position because the inlet to the oil supply line from the tank to the engine will be left uncovered and the oil pump will be air-locked. This can be prevented by incorporating a device in the oil tank so that the tank outlet is always immersed. One such device is shown in the detail at the right of Fig. 218. The clogging effects of sludge as well as the peculiar inertia forces in certain maneuvers have caused difficulty with sticking in these arrangements, and therefore none of them has come to be widely accepted as being entirely satisfactory.

Oil Separators.—Since oil is mixed with the air in the exhaust from an engine-driven vacuum pump, an oil separator is usually installed in this line. The oil is returned directly to the tank or to the "oil-out" line. This feature is necessary for airplanes using de-icers, for the oil in the air is very harmful to the rubber de-icer boots. Such ships generally have two separators, one of especially high efficiency. Other ships generally use separators too, for the oil loss is appreciable, although some commercial ships simply exhaust the vacuum pump overboard.

References

1. WORTH, W.: Lubrication and Cooling Problems of Aircraft Engines, *S.A.E. Trans.*, vol. 32, 1937.
2. MOERMAN, H. E.: Aircraft Oil System High Altitude Problems, S.A.E. National Aeronautical Meeting, April, 1943.

CHAPTER XXIII

ACCESSORIES AND SPECIAL EQUIPMENT

A considerable number of special instruments and controls as well as accessories must be mounted on the engine. The exact nature and extent of this equipment depend on the installation. All types of airplane, however, from light planes to heavy bombers, have come to require increasingly large numbers of complicated devices both to improve some phase of engine operation and to supply power to other mechanisms in the airplane, such as de-icers, gun turrets, and landing flaps. The resulting complications to the engine installation have been considerable; yet they are necessary, and the best possible provision must be made.

ACCESSORIES

In addition to the magnetos and carburetors, a fuel pump and starter are almost always provided in engines of more than 100 hp. A generator, vacuum pump, hydraulic pump, and possibly an air compressor are commonly needed for 400 hp and larger engine installations.

Starters.—The hand-cranked inertia starter was the first type of aircraft starter to be widely used. It consists of a flywheel at the rear, driven through a gear system from a shaft at the side arranged to be cranked by hand. A three-jaw clutch at the front is also geared into the system. Operation of a small lever at the side will permit the clutch to move forward and engage the jaws on the starter shaft in the engine. The gear ratio between the flywheel and the hand crank is about 40 : 1 so that a considerable amount of kinetic energy can be stored in the flywheel when it is cranked to a high speed. The control lever can then be operated to permit the clutch to engage and thus motor the engine over a few revolutions.

A more convenient unit to operate is the electric inertia starter. Its construction is similar to the hand-cranked inertia starter

except that an electric motor at the rear drives the flywheel. *Direct-cranking* electric starters are even more convenient. No control is needed except a button, which may be pushed to close the starter switch. The construction of the front portion is similar to that of the other two types, but the rear part makes use of a strong d-c electric motor, which develops sufficient torque to crank the engine (see Fig. 220). It should not be operated

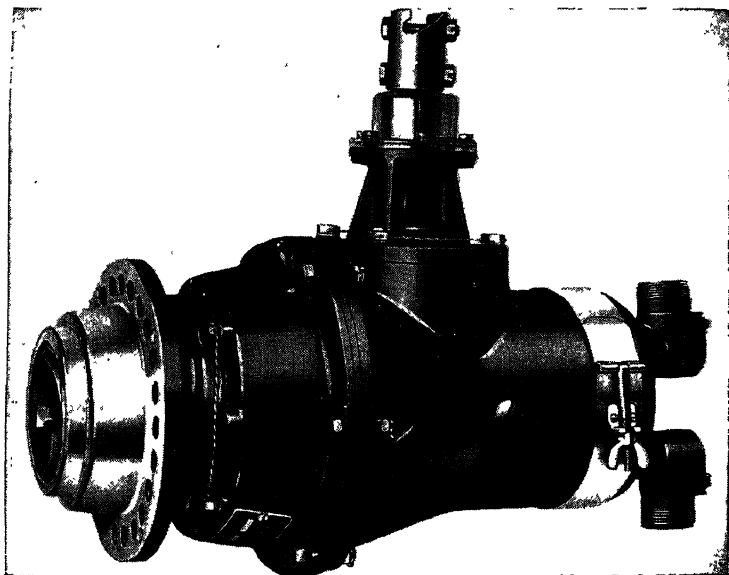

FIG. 220.—Direct-cranking electric starter with provision for hand cranking.
(Bendix Aviation Corp.)

continuously for more than about 1 min., or it will overheat. An engine should start after only a few revolutions.

A number of *combustion, or shotgun*, starters are available. The pressure developed by the combustion of a slow-burning powder in a shotgun-type cartridge is transmitted to a cylinder and piston. The piston drives a helical spline to turn the engine over. A starter of this type will “whip” the crankshaft over very rapidly for somewhat less than a revolution, after which it will “coast” for another revolution or two.

Combustion starters are light and quite effective for some applications. They have the disadvantage that the breech in which the cartridge is loaded may not be located more than about 2 ft from the starter. This means that the engine cannot be

started entirely from the cockpit except in a few small single-engine airplanes in which the pilot is placed just behind the engine.

Shock-cord starters are sometimes used in emergencies or under special conditions in which a starter cannot be employed. These make use of one or more heavy rubber shock cords connected to a propeller blade by means of rope. The rope is attached to a boot placed over the end of the blade. The shock cords are stretched by means of a block and tackle at the other end. When the propeller is released, it is accelerated very rapidly through about one-third of a revolution and then continues to spin for as much as another revolution. The arrangement is obviously bulky, awkward, and less desirable than the other starters mentioned.

Generators.—Both d-c generators and a-c alternators are in use. The former are much more common, for they lend themselves well to control and are easily fitted into a storage-battery electrical system. They require voltage regulation equipment as well as automatic cutouts.

Hydraulic and Vacuum Pumps and Air Compressors.—A number of different types of both hydraulic and vacuum pump are in use. While most air compressors make use of a simple cylinder and piston, all these are built to fit standard four-stud square pads, which may be located on the rear of the engine or on an accessory drive gearbox. Both an inlet and an outlet line must be connected to all hydraulic and to most vacuum pumps, though only a single pressure line need be connected to an air compressor.

Accessory-drive Gear Boxes.—If a larger number of accessories are needed than the number of accessory-drive pads on the engine will accommodate, an accessory-drive gearbox such as that shown in Fig. 6 may be used. Such an arrangement makes it possible to place most of the accessories behind the fire wall where they may be serviced easily.

Auxiliary Power Plants.—The heavy demands for electrical power in large airplanes have led to the development of small power plants designed specifically for this purpose. These are self-contained units with their own engines, governors, and automatic temperature-control equipment. They may be equipped with either d-c or a-c generators, which in some units may also be used for starting the engine. Voltage regulation and reverse

current cutout equipment is also included. They may be mounted in any convenient spot in the airplane. They are designed to operate on aviation gasoline, which may be supplied from the main fuel tanks.

Gun Synchronizers.—All the larger engines are provided with pads on which gun synchronizers may be mounted. These ordinarily are electrical devices that render a gun inoperative for the correct intervals during each revolution to permit the propeller blades to pass the gun muzzles. One is used for each gun.

SPECIAL INSTRUMENTS

Torque Meters.—The torque meter has proved a valuable instrument in flight test work. It makes possible the determina-

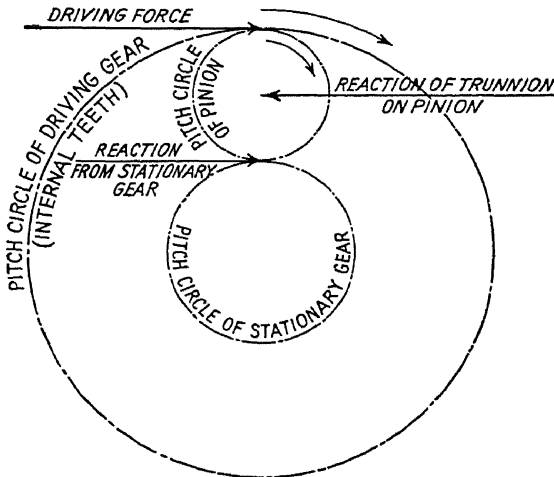

FIG. 221.—Diagram showing the forces acting on a pinion of a straight planetary spur-type reduction gear.

tion of engine power output with an error of less than 1 per cent. When an airplane is being flight tested to determine its flight characteristics, it is absolutely essential to know the brake-horsepower output to evaluate the rest of the data properly. If an airplane did not meet take-off specifications, for example, the airplane manufacturer might ascribe this to the fact that the engine was not delivering the power it was supposed to. With the torque meter installed, there can be no question as to the engine power output. Even more important, the torque meter

makes it possible to determine the effects of relatively small changes in the drag of the airplane. Another valuable application of the torque meter is in long-range multiengine airplanes in which close control of engine power output and fuel consumption is essential if the maximum pay load is to be carried.

The torque meter depends on the reaction force on the stationary member of the reduction-gear system. Figure 221 shows the forces acting on a pinion in a planetary spur-type reduction gear. The vector at the top represents the driving force from the large internal driving gear on the crankshaft. The reaction force from the propeller shaft acts on the trunnion at the center of the pinion. The pinion is restrained from spinning freely by the reaction force imposed at the bottom by the stationary gear. The stationary gear in a torque meter is mounted so that it is free to rotate except insofar as it is restrained by a piston. Figure 222 shows the elements of the system. A small gear pump delivers oil to the cylinder above the piston. When the pressure in the cylinder rises to a value great enough to overcome the reaction force from the stationary gear, the piston is driven to the right. Only a small amount of movement is necessary to uncover ports in the walls of the cylinder and relieve the pressure. A pressure gauge tapped into the top of the cylinder will register a pressure that is directly proportional to the torque reaction on the stationary gear. This, in turn, is directly proportional to the torque acting on the propeller shaft, as can be seen from Fig. 221. The proportionality constants can be computed from the dimensions of the various elements of the system and can be easily checked by static tests or by full-scale engine testing on a dynamometer. It is interesting to note that tests of the latter type indicate that the torque meter is more accurate than most dynamometers. This is probably due to the fact that the dimensions of all the parts in a torque meter are held within a few thousandths of an inch, whereas the distances between the knife-edges on the various members of the dynamometer scale linkage cannot be held to such close limits. If desired, the torque-meter pressure gauge may be calibrated on the basis of this constant to read in terms of bmep to give a conveniently used engine parameter.

Exhaust-gas Analyzers.—A number of different types of exhaust analyzers have been built. Those used on aircraft

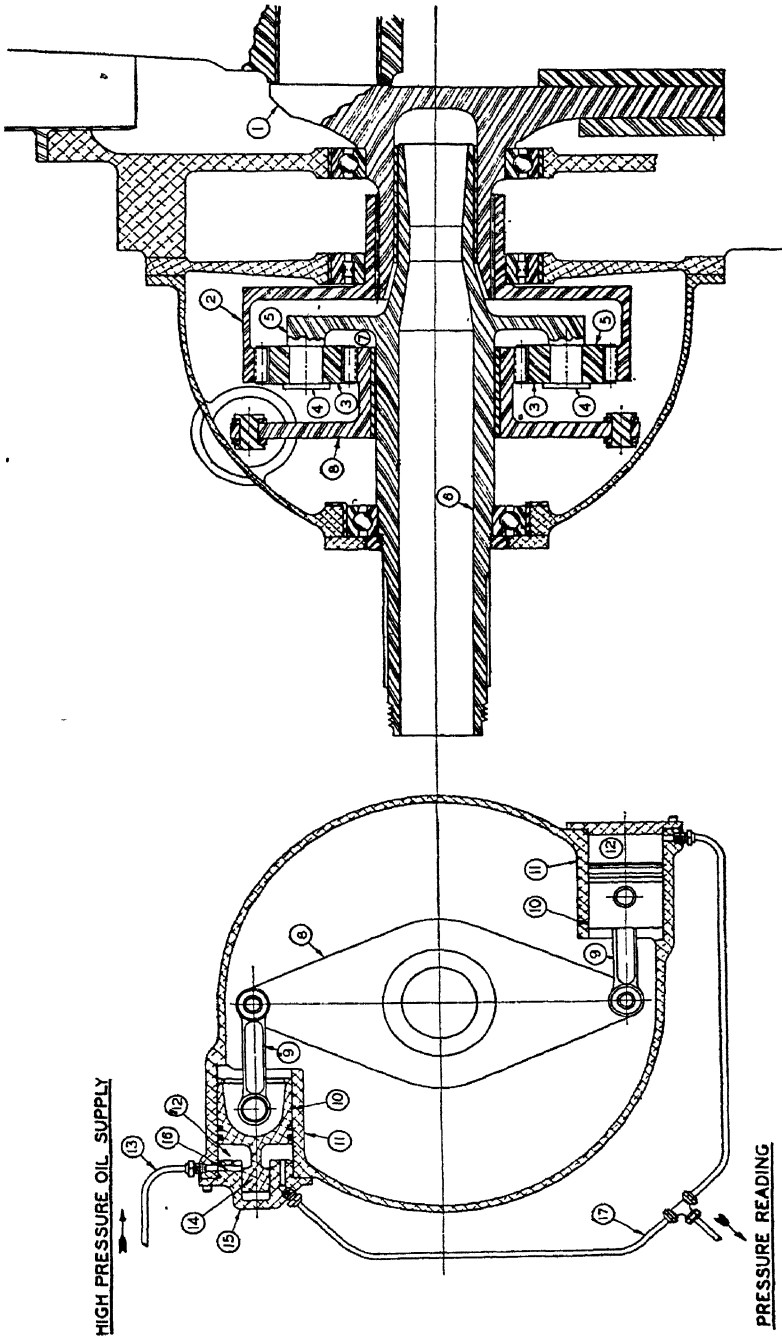

Fig. 222.—Diagrammatic sketch of a torque meter. (*Buck and MacClain, S.A.E. Trans., vol. 32, 1937.*)

engines depend on the variation in the composition of the exhaust gas to indicate the fuel-air ratio of the mixture supplied to the engine. Figure 35 shows the variation in the composition of the exhaust gas with the fuel-air ratio. Note that the carbon dioxide content increases rapidly as the mixture is leaned out to a fuel-air ratio of 0.067, after which it again falls off, while the

RELATION BETWEEN THERMAL CONDUCTIVITY OF EXHAUST GAS AND FUEL-AIR RATIO

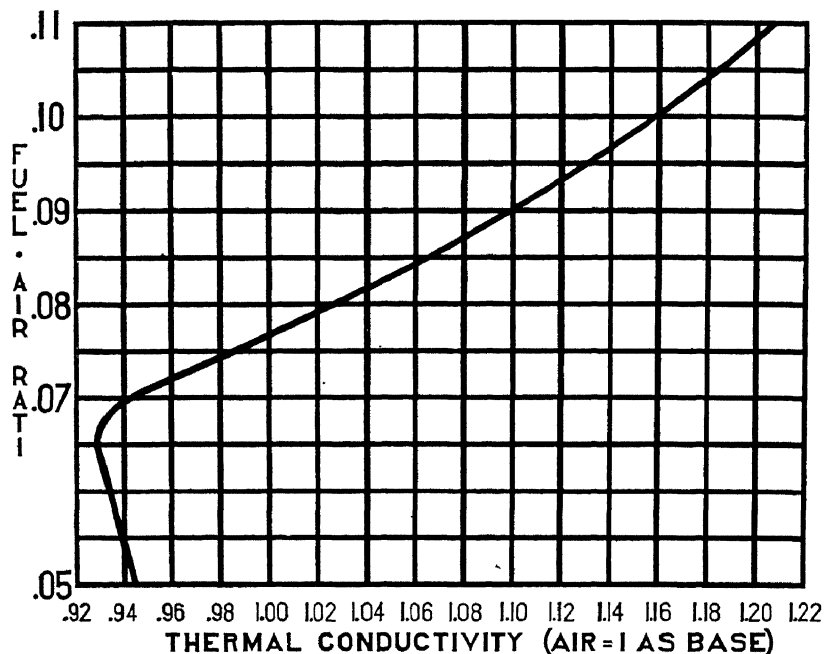

FIG. 223.—Thermal conductivity of exhaust gas as a function of the fuel-air ratio of the mixture supplied to the cylinders. (Cambridge Instrument Co., Inc.)

hydrogen and carbon monoxide contents fall off very rapidly to become zero at fuel-air ratios equal to, or leaner than, that for the chemically correct mixture, *viz.*, 0.067. Figure 223 shows the variation in the thermal conductivity of the exhaust gas due to these changes in its composition. Since operation is normally carried out with mixtures that are richer than the chemically correct value, the change in thermal conductivity of the exhaust gas can be used to indicate the fuel-air ratio.

The type of instrument most commonly employed makes use of two resistances placed in adjacent cells in a brass block. Exhaust gas is allowed to pass through one cell while the other cell is filled with air saturated with water vapor. Since both cells must be at the same temperature because they are in the same brass block, the amount of water vapor present will be the same in both. These two resistances can be connected in series and heated by an electric current. Variation in the composition of the exhaust gas surrounding one of these resistances will cause

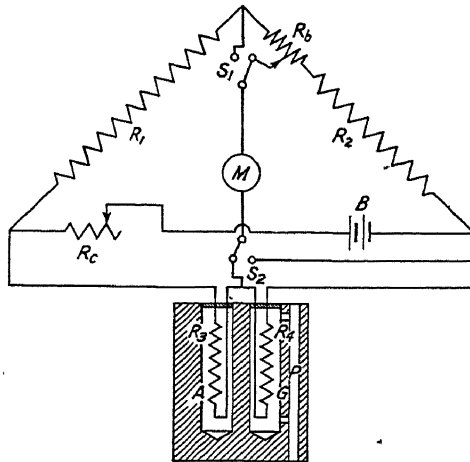
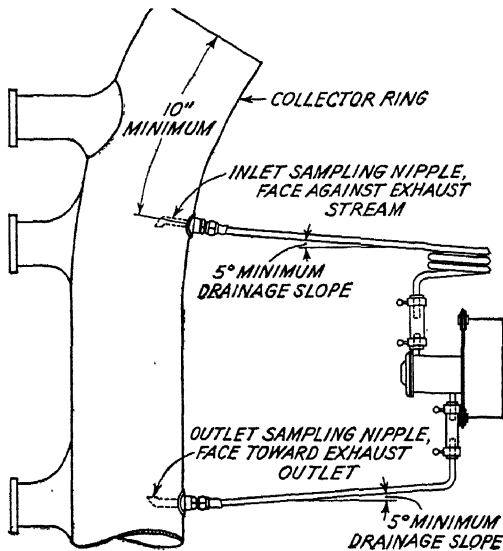

FIG. 224.—Diagram showing the principles of operation of an exhaust-gas analyzer. (Dilworth, *S.A.E. Trans.*, vol. 49, 1941.)

heat to be conducted from it at varying rates. This will cause its temperature, and hence its resistance, to change. The change in its resistance relative to that of the element in the air cell can be measured with a Wheatstone bridge. Figure 224 is a wiring diagram illustrating the principle of operation. The galvanometer M can be calibrated in terms of fuel-air ratio. The resistance R_c can be adjusted to give the proper flow of current, while the resistance R_b can be adjusted to balance the bridge when both cells are filled with saturated air.

In some instruments the resistances in the cell are made of platinum and operate at a red heat. A small amount of air is mixed in the exhaust gas before it is passed through the analyzer cell. The red-hot platinum wire acts as a catalyst to bring about combustion of the hydrogen and carbon monoxide in the exhaust gas. Since this combustion takes place on the surface of the wire,

it causes a pronounced increase in the temperature and a corresponding change in resistance. The effect of changes in the exhaust-gas conductivity are small as compared with the effect of the gases burned, so that a somewhat more sensitive instrument can be built. A characteristic common to all types of exhaust analyzers is that they are inaccurate at fuel-air ratios leaner than 0.067.² If used in the rich range, they give a satisfactory means of determining the fuel-air ratio, but they have



1.—Installation of an exhaust-gas-analyzer sampling cell. (Cambridge Instrument Co., Inc.)

been unsatisfactory for very lean mixtures. This is as one would expect from an examination of Fig. 223. Since normal operation is at fuel-air ratios richer than 0.067, these types are satisfactory.

The installation of exhaust-gas analyzers in the airplane varies somewhat with the unit employed. Care must always be taken to ensure cooling of the exhaust gas by means of a cooling coil. This should be so arranged that water that condenses out of the exhaust gas will drain off easily. Figure 225 shows a recommended installation of the analyzer cell. The pressure drop across the analyzer cell should be sufficient to ensure an adequate flow of exhaust gas, but it should not be greater than the value specified by the analyzer manufacturer. The analyzer cell should be located at a point where its operating temperature will not be more than 125°F.

AUTOMATIC CONTROLS

Propeller Governors.—Engine crankshaft rpm may be maintained constant with an automatic propeller-pitch control, which will cause the propeller pitch to increase if the rpm increases and thus tend to slow the engine down. If the engine rpm drops below the value for which the governor was set, the pitch will be automatically reduced and the load on the engine will be decreased. The mechanics of propeller governors and pitch-changing mechanisms is discussed in Chap. XXVI.

The propeller governor is usually mounted on a special pad provided for this purpose on the nose of the engine. A separate control in the pilot's cockpit is connected to the governor. This control may be set to any desired position to maintain engine speed within about 10 rpm of the value desired, thus greatly simplifying the task of engine control.

In multiengine ships, it is desirable to synchronize the engines to the same speed. This requires rather complex instrumentation and control equipment, but may be justified by improved passenger comfort and decreased maintenance cost.

Manifold-pressure Regulators.—A number of "supercharger regulators," or "boost controls," have been developed. These, when used in conjunction with propeller governors, will automatically maintain an essentially constant power output. Since it is difficult to make a unit that will operate on the basis of power output, the most widely used devices depend on engine manifold pressure. Units built to operate on this basis can be quite simple in construction. Since the operating force available from the manifold pressure is rather small, the units ordinarily employ evacuated capsules, which operate a valve that controls a servo piston. A linkage is used to connect the servo piston to the carburetor throttle. The unit operates to maintain a constant manifold pressure. At a constant rpm, this gives an essentially constant power (see Fig. 58). In most cases the throttle control is connected directly to the automatic-control unit, and the carburetor throttle is operated through that device.

References

1. BUCK, R. S., and A. L. MACCLAIN: Flight Testing with a Torque Indicator, *S.A.E. Trans.*, vol. 32, 1937.
2. DILWORTH, J. L.: Characteristics of Exhaust Gas Analyzers, *S.A.E. Trans.*, vol. 49, 1941.

CHAPTER XXIV

INSTALLATION TESTING

It would be difficult to exaggerate the importance of the part that testing plays in the development of an engine installation. The wide range of requirements imposed on high-performance airplanes makes it difficult to meet them all. Their complexity is such that it is impossible to predict in advance just how well any one element will work. The only practicable solution is testing. Until about 1940, testing usually meant that the prototype airplane was built with the arrangement and parts thought best by the designers. After one or more ground and flight tests on the airplane, the more serious troubles would become evident. New parts intended to remedy the difficulty would then be designed, fabricated, and tested. If they were not satisfactory, a different solution would have to be tried.

Flight testing has the disadvantage that flight testing of the whole airplane may have to be delayed while, for example, the cooling air shutter on the oil cooler is being reworked to give improved cooling. Of the mechanical equipment in an airplane, a large part—at least 75 per cent—is a part of or directly connected with the engine. Because of this, a large part of the airplane manufacturer's flight-testing program has had to be devoted to the development of the engine installation. Serious delays have resulted. They have usually been followed by a number of postponements in production schedules, for airplanes cannot be built in production if they cannot meet their specifications. Sometimes more than a year of flight testing has been necessary. This has often meant that an airplane has become obsolete before the many troublesome and seemingly small defects have been corrected.

Aside from the inestimable loss due to delays in the production schedule, the direct cost of flight testing is quite high. Figure 226 shows a curve giving the approximate cost of flight-test time in terms of dollars per hour. It is evident from this that,

particularly in multiengine ships, it should be well worth while to build and test units of the installation while the prototype

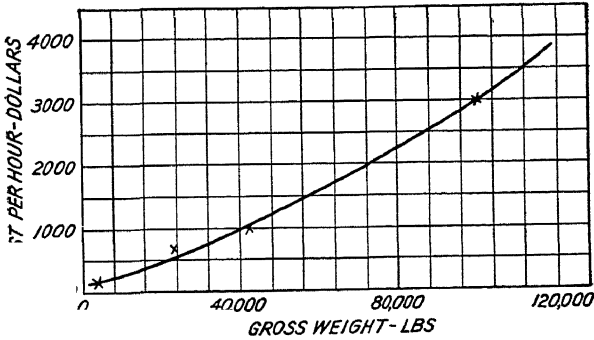

FIG. 226.—Flight-testing cost as a function of airplane gross weight. (Kendrick, S.A.E. Trans., vol. 50, 1942.)

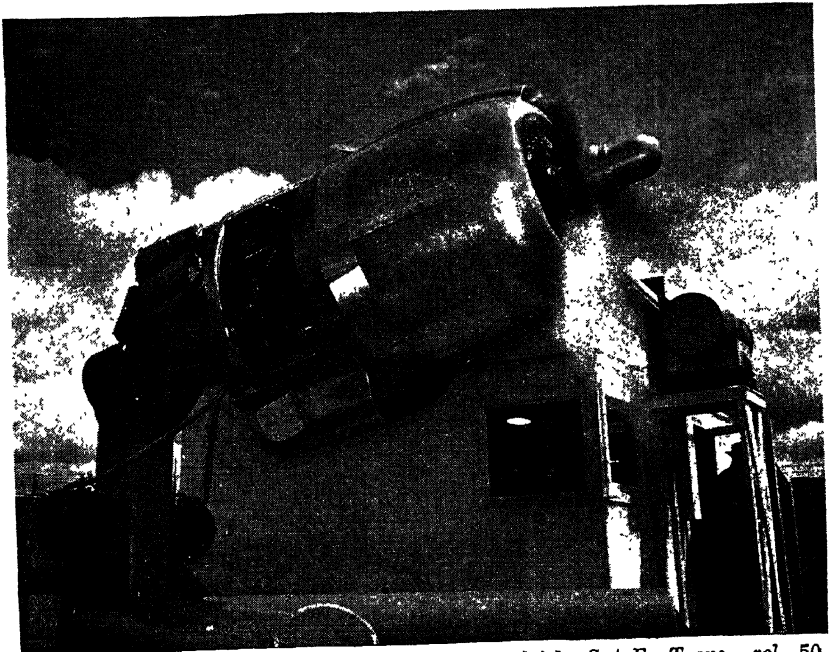

FIG. 227.—Engine-installation test unit. (Kendrick, S.A.E. Trans., vol. 50, 1942.)

airplane is being built. The carburetor air scoop can be tested in an air box, while the plumbing for the fuel system can be set up and flow tested. Similarly, other elements such as the oil

cooler with its cooling air duct and controls may be tested as units. A complete installation like that shown in Fig. 227 may then be built. A large part of the test work that would otherwise be necessary in flight can be carried out on a unit of this sort. If a wind tunnel of sufficient size and a sufficiently high air speed is available, a fairly complete set of tests may be carried out. The cost of full-scale wind-tunnel testing of this sort is very high but may be justified for large airplanes. Such testing has the additional advantage that the effect of small changes in drag due to such items as the cowling or the air scoop may be evaluated.

NATURE OF TESTS

Irrespective of the methods employed to develop the installation, the complete airplane must be tested to make certain that temperatures and pressures fall within the prescribed limits for the various critical operating conditions. These conditions are usually idling on the ground, taxiing, take-off, rated-power climb at the best climbing speed, high-speed level flight, level flight at the maximum cruising power with mixtures giving the guaranteed minimum specific fuel consumption, rated-power operation at each of the critical altitudes, and, in multiengine ships, climb with the maximum number of engines inoperative.

Cylinder Cooling.—Perhaps the greatest problem in the development of an installation is adequate cooling. Cowl shape, exit-flap shape, size, and location, and other factors must be varied until satisfactory cooling is obtained. The pressure drop across the cylinder baffles is the best indication of cooling air flow and should be measured. Since cooling may not be uniform for all cylinders, the head and base temperature of each cylinder should be checked. The temperature of the spark-plug elbows should be watched, particularly at high altitudes; for if they exceed about 250°F, charring of the insulation and ignition failure may be expected.

Oil Cooling.—It was pointed out in Chap. XII that the heat rejection to the oil varies with the amount of oil cooling done by the crankcases. This is a function of the installation. The oil inlet and outlet temperatures to both the engine and the cooler should be measured so that both the heat rejection of the engine and the capacity of the cooler may be checked. The pressure

drop in the cooling air stream through the cooler should be measured to indicate the cooling air flow. Proper functioning of all automatic-control devices should be checked, but they should be disconnected during those parts of the test where they might interfere with the data, as would be the case with a thermostatically controlled cooler by-pass valve, for example.

Accessory-compartment Temperatures.—The temperature of many points in the accessory compartment may become dangerously high if ventilation is not adequate. The magnetos, the generator, and the other electrical equipment must be kept below the temperatures specified by the manufacturer. The rubber mounting bushings should operate at temperatures of not more than about 160°F. The fuel temperature at the inlet to the carburetor should not be much greater than that in the fuel tanks, or vapor lock will be likely.

Induction System.—The arrangement for a heated air supply to the carburetor should provide the temperature rise required by the specifications. For nonicing carburetors, this is indicated by Fig. 195. On the other hand, multistage supercharger installations must be tested to ensure adequate cooling of the carburetor air. Such installations also require a considerable amount of testing near and above the highest critical altitude to determine their characteristics, especially from the standpoint of the superchargers, intercoolers, and ductwork. The operation of the control valves for both the cooling and the engine air as well as the automatic-control equipment must be checked. The pressure at the carburetor inlet is important for all types of installation under all critical-performance conditions, for it has a direct effect on the engine power output available. It must be measured to evaluate the effectiveness of the air scoop.

Carburetor metering is important especially in long-range airplanes. The effects of the induction system under the more important flight conditions should be investigated carefully, for wide variations have often occurred. Tests should also be made on the effects of operation with the hot-air valve both partly and fully open. Carburetion work of this sort requires accurate measurement of both fuel flow and horsepower. The latter may be measured with a torque meter, while the former may be found by taking weight flows or from an accurate flowmeter. The displacement-type flowmeters have been found to be especially

suited to flight work, for they are unaffected by flight attitude or maneuvers. Of course, air or vapor bubbles in the fuel will cause inaccurate readings with any type of instrument. The flowmeter should be installed where trouble from this source is least likely.

Fuel System.—The extent of the tests to be conducted on the fuel system depends largely on the altitude at which it is to operate. Flow tests must be run on the ground to ensure the delivery of adequate quantities of fuel for take-off power at sea level, while special flight testing at high altitudes may be necessary to ensure freedom from vapor lock. Of course, fluctuation of fuel pressure or irregularities in engine operation during take-off or any phase of flight must be watched for, as they indicate that large bubbles of air and vapor are reaching the carburetor.

Oil System.—In addition to the special work carried out on the cooler, the oil system should be watched and possibly tested. Oil-pressure fluctuations indicate that air bubbles are being pumped into the engine with the oil. An air leak in the oil inlet line may be responsible. Such an air leak often occurs if the suction at the oil inlet connection is made too great by restrictions in the line. Air bubbles in the oil returned to the tank may also cause the difficulty if they are not being properly separated out but are recirculated with the oil. Scavenging difficulties at high altitudes are likely to give trouble and require test work.

Exhaust System.—The exhaust back pressure should be checked at a number of points to make certain that it is uniform for all cylinders and that it is not excessive. The exit opening from the manifold may require a change in location, size, shape, or inclination to make the discharge clear the airplane and prevent its impingement on any surfaces.

Vibration.—Vibration tests on the propeller blades and on the airplane structure must be conducted to make certain that vibratory stresses and amplitudes are acceptable. Aerodynamic interferences often give an entirely different set of blade-vibration characteristics from those obtained on an engine test stand. Engine movement and possibly engine vibration may require investigation.

Endurance Testing.—The ruggedness and durability of parts may be determined to some extent during the course of the

flight-test program. Such tests are not economical except as a by-product of the regular test work. The flying time of the various parts should be logged and the service difficulties carefully investigated. If power-plant units are tested as shown in Fig. 227, it is often worth while to run endurance, or "shake-down," tests. Long hours of vibration are surprisingly hard on all parts. Actual test work is the only practicable check on their durability before the airplane is put into service. Difficulties that occur after the airplane is delivered to the customer are expensive not only in terms of the cost of the replacement parts that must be made, but even more so in terms of the poor impression made on personnel outside the airplane manufacturer's plant. It is a well-known but not always recognized fact that, when the time comes to order more equipment, past service difficulties have a greater effect on a customer's decision than airplane performance. A good endurance-test program will greatly reduce service difficulties.

CONDUCT OF THE TESTS

Test Program.—A complete test program is laid out for each new model airplane. It includes test work to be carried out with units on the ground as well as ground and flight testing of the airplane. Flight test work is carefully scheduled to obtain the maximum results from a given amount of flying time. The more important elements such as engine cooling and carburetion are checked first so that they will not interfere with later steps in the tests. Each flight is carefully planned, and all phases of engine operation are observed for signs of trouble.

Recording of Data.—One or more observers may go on each flight to read and record data. At altitudes above about 10,000 ft the physiological effects of the reduced oxygen supply are such that the accuracy of observed data begins to be affected. Even with oxygen masks, it is generally impossible to do a rapid yet accurate job of reading and recording data at altitudes above 28,000 ft. One convenient solution has been to mount the instruments in a close group and then take pictures of them. Two or three frames may be taken for each reading. Instruments included to identify the frame are a clock, an altimeter, and an air-speed indicator. The rest of the instruments give oil pressure, oil-in temperature, manifold pressure, bmep, and other

pertinent engine data. The pictures can be analyzed on the ground; the instruments read, and the data transferred to log sheets. An arrangement of this sort is especially convenient in pursuit ships, for the pilot can take data simply by pressing a

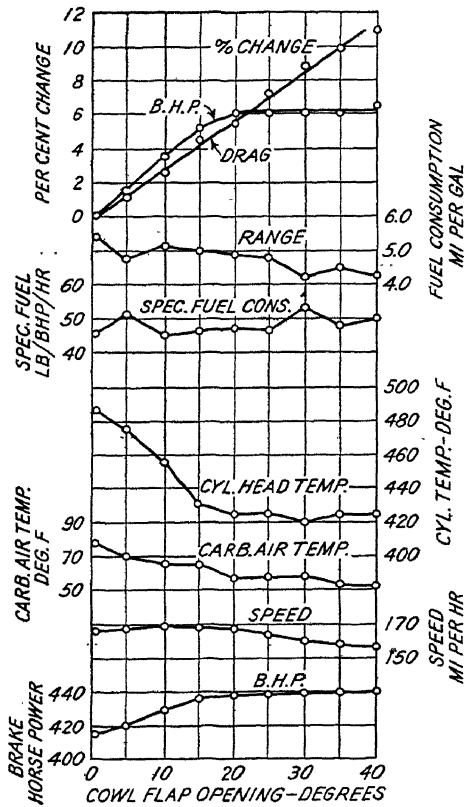

FIG. 228.—Effect of cowl-flap opening on airplane speed, cylinder-head temperatures, and other important factors. Data from flight tests at full throttle, 2,100 rpm, and 10,000 ft. (*MacClain and Buck, S.A.E. Trans., vol. 33, 1938.*)

button. Electrical relays and equipment may be arranged to take the pictures.

Correction of Data.—Weather conditions usually afford temperatures differing considerably from both standard and the standard "hot day." Temperature data must often be corrected to one or the other of these, depending on the character of the test. Where the only factor is the atmospheric temperature, the correction is simply equal to the difference between

the standard temperature and the prevailing atmospheric temperature. Carburetor air and cylinder-head temperature at particular flap openings, for example, may be corrected in this way. Other temperatures such as those of rubber mounting bushings and of the magnetos are partly dependent on engine temperatures, and thus empirical factors must be used to correct for cooling air temperature. The engine manufacturer can usually supply approximate values for these factors.

Figure 251 shows both standard air temperature and one typical of the several hot-day standards based on 100°F ground air

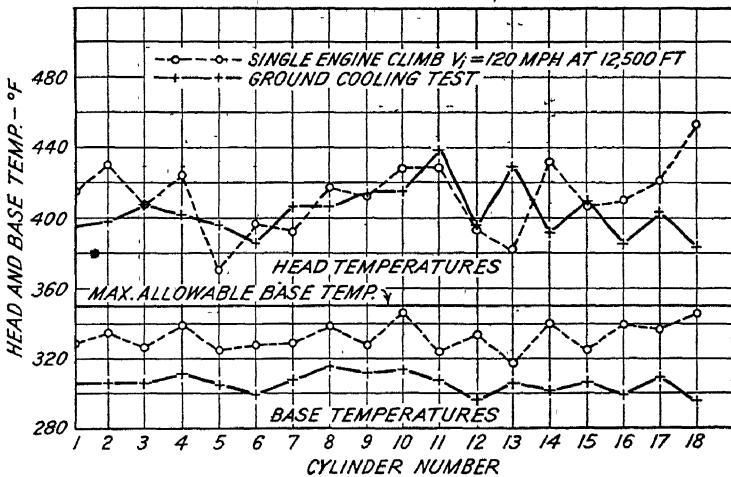

FIG. 229.—Cylinder-head and -base temperatures. (*Kendrick, S.A.E. Trans., vol. 50, 1942.*)

temperature. The temperature of all elements in the installation should still be satisfactory under any flight condition when corrected to the standard hot-day temperature.

Test Results.—The character of the results from a number of actual tests may be of interest. Figure 228 shows the effect of cowl-flap opening on cylinder-head temperature and air speed for full-throttle altitude operation in level flight. Carburetor air temperature, engine power output, specific fuel consumption, and airplane range are also shown as functions of cowl-flap opening. This test clearly indicated that opening the cowl flaps beyond the 15-deg position gives little improvement in cooling but a considerable increase in drag.

An interesting comparison between the test results obtained on the test unit shown in Fig. 227 and the flight tests on the completed airplane has been made.¹ Figure 229 shows a plot of cylinder-head and -base temperatures for both ground tests on the installation test stand and flight tests. The correlation between the cylinder-head temperatures was generally good both for the average temperatures and for the temperature of individual cylinders. The discrepancy between the base tempera-

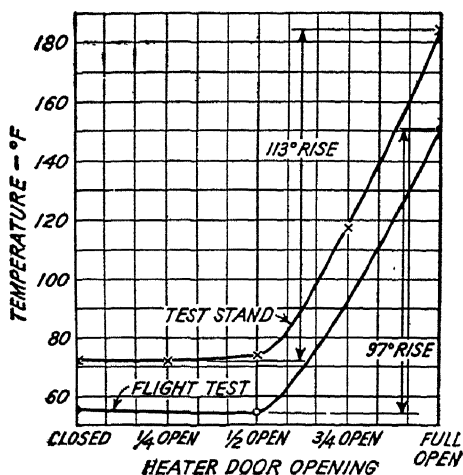

FIG. 230.—Carburetor air temperature rise. (*Kendrick, S.A.E. Trans.*, vol. 50, 1942.)

tures for the two tests is rather large and might have been serious. Figure 230 shows the effect of heater-door position on carburetor inlet air temperature for both test stand and flight tests, while Fig. 231 shows the variation in exhaust back pressure at two points in the exhaust manifold for operation along a propeller-load curve. Table VIII shows the observed temperatures in the accessory compartment for the various test conditions. In all these cases, fairly good correlation was found between the two types of test. However, cooling under level flight conditions presents problems that cannot be solved on a simple test stand because conditions are not sufficiently similar.

Summary.—The results of installation tests must be studied carefully before a decision on a change is made. Test conditions have a profound effect on test results and must be allowed for properly. The method by which the test was conducted may

also be open to question. In any case, a new installation must pass a satisfactory test program before it goes into service. The more nearly such a program approaches critical service

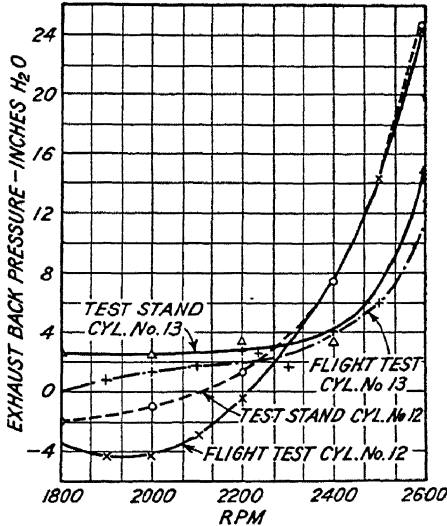

FIG. 231.—Exhaust back pressure. (*Kendrick, S.A.E. Trans., vol. 50, 1942.*)

conditions, the less the difficulty the airplane operator experience.

TABLE VIII.—CORRECTED ENGINE COMPARTMENT AND ACCESSORY TEMPERATURES, °F.

Test condition	Maximum accessory compartment temperature	Maximum flexible pedestal temperature	Maximum fuel-line temperature	Maximum spark-plug temperature
Test stand	155	219	128	247
Ground cooling on airplane.	142	229	124	258
Maximum observed temperature during flight.	161	201	112	108

References

1. KENDRIC, J. B.: Ground Versus Flight Tests of Airplane Engine Installations, *S.A.E. Trans.*, vol. 50, 1942.
2. MILLER, L. C.: Determination of Airplane Critical Altitude by Flight Tests, *Jour. I.A.S.*, vol. 9, No. 13, 1942.

PART III

Propellers

CHAPTER XXV

PROPELLER THEORY AND PERFORMANCE

The power plant of an airplane differs from that of the automobile or the railroad locomotive in that its output is not directly applied to produce forward motion. In vehicles propelled by the wheels on which they ride, one revolution of the power-plant drive shaft results in a definite amount of forward motion. No such explicit relation exists between the propeller shaft of an aircraft engine and the forward motion of the airplane. In the airplane engine, shaft horsepower must be converted into thrust horsepower through the medium of a propeller, or airscrew. Thus the efficiency and other characteristics of the aircraft propeller are of vital importance, for they determine the amount of the engine power output that produces useful thrust on the airplane. Since it is perfectly possible for a propeller to absorb the entire output of an engine and yet do little or no useful work, it is apparent that the problem of the propeller deserves much attention. Further, the characteristics of the propeller impose requirements that the engine must be designed to meet. There are a number of theoretical approaches to the subject; but, before discussing these, let us consider the actual propeller and its appearance.

Nomenclature.—Propellers are comparatively simple in construction. The outer end of the propeller blades is referred to as the *tip*, while the inner end is spoken of as the *shank* in metal propellers. The center section in which the blades are mounted is called the *hub*. The diameter of the circle swept by the propeller while revolving is usually called the *diameter* of the propeller.

A readily apparent characteristic of the propeller is the variation in the angle of the blade from the shank at the hub to the tip. This blade angle at each point is usually such that, if the propeller were screwing itself forward in a solid medium, the advance per revolution would be the same for every portion of the blade. That is, the product of the tangent of the blade

angle at any particular point and the circumference of the circle along which that point on the blade moved would be approximately constant for all points along the blade. This property of the propeller, *i.e.*, its advance per revolution, is called its *geometric pitch*. Since in flight a certain amount of slippage occurs, its actual advance per revolution may be spoken of as the *effective pitch*.

A second important characteristic of a propeller is the cross-sectional shape of the blades. This is normally in the form of an airfoil, the section being thick and heavy near the blade shank and quite thin at the tip. The number of blades is also a distinguishing feature. Two-, three-, and four-bladed propellers constitute by far the greater portion of the propellers in use.

PROPELLER THEORY

Propeller Efficiency.—The term *propeller efficiency* is used extensively and needs explanation. While another criterion might be evolved, the engineer is primarily interested in knowing how well a propeller converts the horsepower output of the engine into useful work as evidenced by forward motion of the airplane. Thus, the propeller efficiency may be defined as the product of the thrust produced by the propeller and the forward velocity of the airplane divided by the power input, *i.e.*, the power output divided by the power input. This means that, if an airplane is stationary on the ground, the efficiency of the propeller is zero no matter how much force it may exert on the airplane, for it does no useful work in producing forward motion.

Propeller Thrust.—It is evident from the above that the propeller efficiency is of little or no value for determining the thrust, or forward-acting force, available for the initial part of the take-off run. It happens that the thrust is also a very convenient quantity for use in airplane-performance calculations.

Momentum Theory.—One of the first logical theoretical approaches to the problem of propeller thrust and efficiency was based upon the forward thrust obtained by the propeller as a result of the axial momentum imparted to the air flowing through it. According to Newton's law, for every action there is an equal and opposite reaction. To make use of this approach,

one can assume a propeller disk that is perfectly efficient in accelerating the column of air that flows through it. On this basis, it is possible to develop formulas for the thrust and the efficiency for a propeller operating under various conditions. The forward motion of the airplane, the velocity of the air stream which flows through the propeller, the power input to the propeller, the propeller diameter, and the density of the air in which the propeller is operating are all important factors which must be included.

For convenience, the problem may be idealized. The propeller may be assumed to give a uniform acceleration to all parts of the air stream passing through the propeller disk. The air may be assumed to be incompressible and frictionless. On this basis it can be shown that

$$\eta = \frac{2}{1 + \sqrt{1 + \frac{T}{A \frac{\rho V^2}{2}}}} \quad (54)$$

where η = propeller efficiency.

T = thrust, lb.

A = propeller-disk area, sq ft.

V = airplane speed, fps.

ρ = air density, slugs per cu ft.

From this it is evident that an increase in airplane speed or in propeller diameter should give an increase in efficiency, while an increase in the thrust obtained from a given propeller or a decrease in air density will result in a decrease in the efficiency. While these results are subject to the serious limitations imposed by the assumptions made, they represent the ideal condition which we may hope to approach, but cannot exceed.

The momentum theory is evidently not accurate enough for practical purposes of propeller-performance and -efficiency analysis because it is based on an incompressible frictionless fluid that is accelerated uniformly over the entire area of the propeller disk when flowing through it. It does not take into consideration the effects of blade shape, airfoil section, and changes in geometric pitch, nor does it give any expression for the torque input. A method showing these effects would be more useful.

By treating the airfoil just as one would a wing having the lift coefficient C_L , an expression for the thrust can be obtained. The lift force acting on the element of length dr and width b becomes

$$dL = \frac{1}{9} \rho \left[\frac{V}{\sin \phi} \right]^2 C_L b dr \tag{56}$$

Airfoil characteristics are often given in terms of the parameter γ , which is convenient to use. To obtain the thrust, let us first obtain the resultant air force on the element.

$$dR = \frac{dL}{\cos \gamma} = \frac{\rho V^2 C_L b dr}{2 \sin^2 \phi \cos \gamma} \tag{57}$$

The thrust obtained is then

$$dT = dR \cos (\gamma + \phi) = \frac{\cos (\gamma + \phi)}{2 \sin^2 \phi \cos \gamma} \tag{58}$$

To simplify manipulation, let us use a thrust coefficient T_c , defined as

$$T_c = \frac{C_L \cos (\gamma + \phi) b}{\sin^2 \phi \cos \gamma} \tag{59}$$

This coefficient depends only on the geometry of the blade and the helix angle θ . The thrust for the element becomes

$$dT = \frac{1}{2} \rho V^2 T_c dr \tag{60}$$

The thrust acting on each blade of the propeller becomes

$$T = \frac{1}{2} \rho V^2 \int_{r=0}^{r=\frac{D}{2}} T_c dr \tag{61}$$

where D is the propeller diameter.

The torque required to drive the blade element, where Q is the torque in pound-feet, is

$$\begin{aligned} dQ &= dR \sin (\gamma + \phi) r \\ &= \frac{\rho V^2 C_L \sin (\gamma + \phi) b r dr}{2 \sin^2 \phi \cos \gamma} \end{aligned} \tag{62}$$

To simplify the expression, let us introduce the torque coefficient Q_c similar to the thrust coefficient T_c .

$$Q_c = \frac{C_L \sin (\gamma + \phi) b r}{\sin^2 \phi \cos \gamma} \tag{63}$$

The total torque acting on the single-bladed propeller thus becomes

$$Q = \frac{1}{2} \rho V^2 \int_{r=0}^{r=\frac{D}{2}} Q_c dr \quad (64)$$

The efficiency of a propeller-blade element may be readily found. Since by definition the efficiency is the ratio of the thrust horsepower to the horsepower input, the efficiency becomes

$$\begin{aligned} \eta &= \frac{V dT}{2\pi n dQ} \\ &= \frac{V dR \cos(\gamma + \phi)}{2\pi n dR \sin(\gamma + \phi)r} \end{aligned} \quad (65)$$

But

$$\frac{V}{2\pi r n} = \tan \phi$$

And

$$\frac{\sin(\gamma + \phi)}{\cos(\gamma + \phi)} = \tan(\gamma + \phi)$$

Hence,

$$\eta = \frac{\tan \phi}{\tan(\gamma + \phi)} \quad (66)$$

This indicates that the efficiency of a blade element depends only upon the helix angle of the path along which it travels and the lift-drag ratio of the airfoil section. The propeller might be compared to a jackscrew in which the helix angle of the blade path is that of the thread, and the L/D ratio of the airfoil is equivalent to the coefficient of friction of the jackscrew. The expression for efficiency on this basis is identical for both. From inspection of the above formula, it is evident that since γ is small, the efficiency will be greatest for blade angles near 45 deg.

The simple blade-element theory as developed above is not very accurate. One important consideration neglected is the interference effect of each blade on the air flow over the following blades. Tip losses, the accuracy of the airfoil data upon which any numerical calculations might be based, as well as the magnitude of the scale effect involved in the use of airfoil data taken at one Reynolds number for a propeller blade operated at another are some of the other factors that have considerable effect.

PROPELLER PERFORMANCE

Propeller theory is an excellent guide to propeller testing. Several dimensionless coefficients can be obtained from the results of the blade-element theory. While their derivation may seem arbitrary, it has been found from much test work that they are indispensable for the synthesis and analysis of test data. It is on the basis of these coefficients that propeller-performance charts and calculations are made.

Progression Factor.—The most important of the dimensionless coefficients is V/nD , *i.e.*, the airplane velocity divided by the propeller rpm and the diameter. It is evident that this is proportional to the actual pitch, or advance per revolution, and hence to the tangent of the angle ϕ used in the blade-element theory. That is,

$$V = (\tan \phi) \times (\text{a constant}) \quad (67)$$

This is often called J , *i.e.*,

$$J = \frac{V}{nD}$$

This coefficient is much more convenient to use than blade angle because it is expressed in terms applying to the whole propeller instead of just an element. It is sometimes called the *effective pitch ratio* or the *progression factor*.

Thrust and Power Coefficients.—Referring back to the expression for the thrust in the blade-element theory, it is evident that some assumptions are necessary before it can be made usable. The fact that propeller tests are usually run with geometrically similar propellers should be helpful in this respect.

In a given fixed-pitch propeller, both ϕ and γ are a function of V/nD . That is, $\tan \phi$ is proportional to V/nD and γ is a function of $(\beta - \phi)$, *i.e.*, the angle of attack of the blade element relative to the air stream. In a series of geometrically similar propellers β , b , and γ are functions of D . Making use of these relations and substituting them in the expression for thrust, we obtain

$$dT \propto \rho V^2 D^2 f\left(\frac{V}{nD}\right) \quad (68)$$

Letting T_c be a function of V/nD , this becomes

$$T = T_{c\rho}V^2D^2 \quad (69)$$

Similarly, an expression for the torque Q can be obtained, where Q_c is also a function of V/nD .

$$Q = Q_{c\rho}V^2D^3 \quad (70)$$

It happens that these coefficients are more usable if multiplied by $(V/nD)^2$. That is, we may define a new thrust coefficient C_T as

$$C_T = \quad (71)$$

for which

$$T = \overline{(V/nD)^2} \quad (72)$$

or

This can be rearranged to define C_T , which is the thrust coefficient in general use.

$$C_T = \frac{T}{\rho n^2 D^4} \quad (73)$$

Similarly,

$$C_Q = Q_c \left(\frac{V}{n} \right) \quad (74)$$

and

$$\frac{C_Q}{(V/nD)^2} \quad (75)$$

We are usually more interested in using a power coefficient instead of one for torque. Since P , the power absorbed by the propeller, is

$$P = 2\pi nQ \quad (76)$$

we may say that

$$Q \propto \frac{P}{n}$$

Substituting in our last expression for torque and using C_P as a power coefficient, we obtain

$$\frac{P}{n} = C_P \rho n^2 D^5$$

This can be rearranged to give the important definition for the power coefficient, C_P :

$$C_P = \frac{P}{\rho n^3 D^5} \tag{77}$$

Efficiency.—It is sometimes more convenient to use an expression for efficiency instead of that for thrust. Since we have defined efficiency as

$$\eta = \frac{TV}{P} \tag{78}$$

we may substitute and obtain

$$\begin{aligned} \eta &= \frac{C_T \rho n^2 D^4 V}{C_P \rho n^3 D^5} \\ \eta &= \frac{C_T}{C_P} \left(\frac{V}{nD} \right) \end{aligned} \tag{79}$$

Thus the efficiency is dependent only on V/nD , C_P , and C_T .

Speed-Power Coefficient.—It is often convenient to make use of a coefficient that does not involve the diameter. Since these coefficients are dimensionless, they may be combined to define another coefficient. By dividing V/nD raised to the fifth power by the power coefficient, we can obtain an expression in which the diameter cancels out. This is defined as

$$\text{Coefficient} = \frac{(V/nD)^5}{C_P} = \left(\frac{V^5}{n^5 D^5} \right) \left(\frac{\rho n^3 D^5}{P} \right) = \frac{\rho V^5}{n^2 P} \tag{80}$$

The fifth root of this coefficient is more easily handled. Called the speed-power coefficient, it is defined as

$$C_s = \sqrt[5]{\frac{\rho V^5}{n^2 P}} = V \sqrt[5]{\frac{\rho}{n^2 P}} \tag{81}$$

Propeller Tests.—On the basis of this analysis, it is possible to conduct propeller tests with some notion as to what should be varied and how the results should be organized and plotted. The efficiency, the speed-power coefficient, and the progression factor, or the thrust coefficient, the power coefficient, and the progression factor may be used to define completely the aerodynamic characteristics of the propeller. As mentioned before, tests are ordinarily run on one of a series of geometrically similar propellers, so that the coefficients apply to all propellers in the series.

Propeller tests are sometimes made in flight with an actual airplane provided with a hub dynamometer or other means for measuring propeller thrust and power input. Such tests are expensive to run and are subject to many limitations. A more convenient method has been to run tests on either model or full-scale propellers in the wind tunnel. For a given propeller the most important data to be taken are the thrust, air velocity, rpm, torque input, and air density. From these, the various

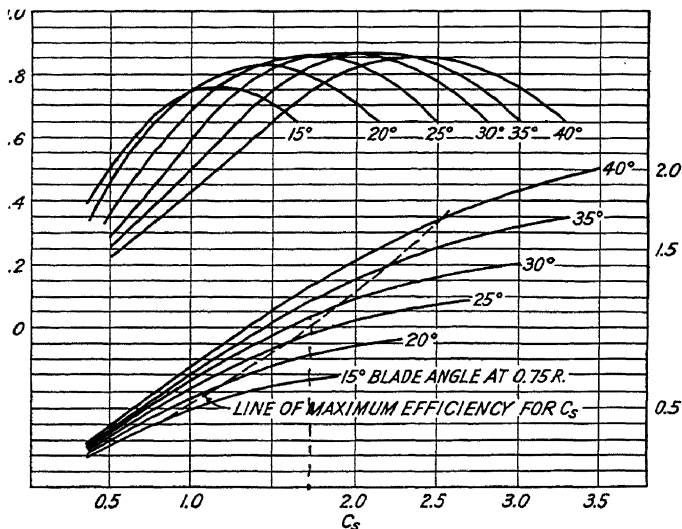

FIG. 234.—Speed-power coefficient and efficiency as a function of V/nD for a three-bladed propeller in a radial engine installation. (*N.A.C.A. Tech. Rept. 642.*)

coefficients can be obtained and plotted. The coefficients then apply over the entire operating range of the propeller.

Propeller-performance Curves.—Curves of J and the efficiency plotted against C_s are shown in Fig. 234. They were obtained with a three-bladed adjustable-pitch 9-ft metal propeller, the blades being set at six different blade angles. The tests were run with the propeller on a radial aircraft engine installed in an actual airplane mounted in the working section of the 20-ft N.A.C.A. propeller research tunnel. A set of curves such as this makes possible the selection of the optimum propeller diameter for a given set of conditions.

Another way of presenting propeller characteristics is to plot curves for the power coefficient C_P against J at constant blade

angles. A second set of curves for the power coefficient C_P can be plotted against J for constant values of the thrust coefficient C_T . A set of these curves for a three-bladed propeller mounted on a cowled liquid-cooled engine is shown in Fig. 235.

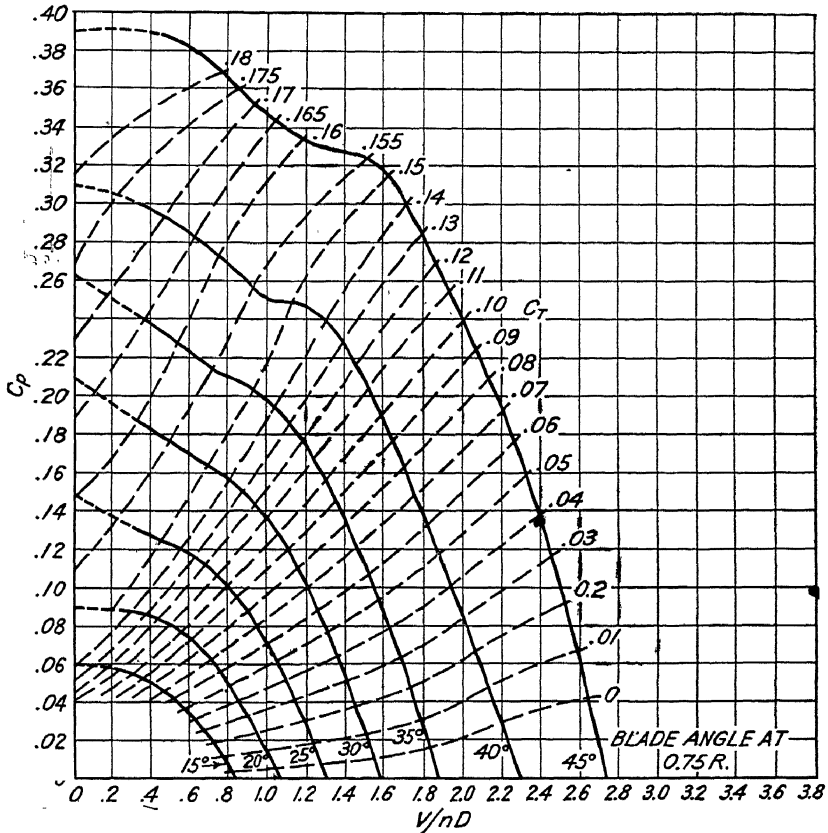

FIG. 235.—Curves for the power coefficient of a three-bladed propeller in a liquid-cooled engine installation. (N.A.C.A. Tech. Rept. 642.)

Curves of this sort are convenient to use for performance calculations.

Effect of Blade Angle.—Figure 236 shows a set of curves run with an adjustable-pitch propeller, each curve representing a different pitch or blade angle. Notice that the higher the pitch of the propeller, the greater its maximum efficiency and the greater the value of J at which it occurs. Note also that the efficiency for each blade setting finally drops to zero as J is increased. That is, at a point where the air speed gives an

advance per revolution approximately equal to the geometric pitch of the propeller, the thrust becomes zero. A further increase in the air velocity would cause it to drive the propeller, and the efficiency would become negative.

These curves clearly show the desirability of a variable-pitch propeller. A fixed-pitch propeller gives good efficiency for only one set of flight conditions, while a variable-pitch propeller can be adjusted to give good efficiency under all flight conditions.

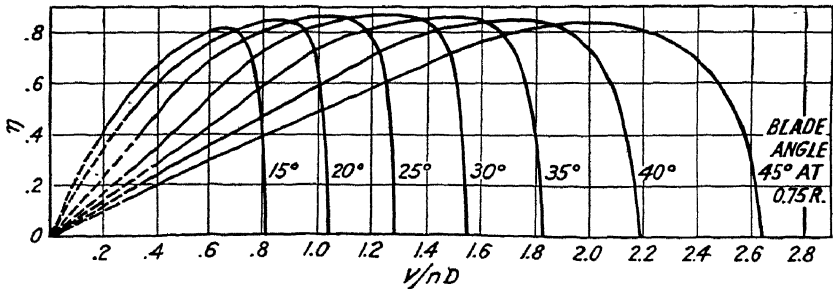

FIG. 236.—Efficiency as a function of V/nD for each of many blade-angle settings. (N.A.C.A. Tech. Rept. 642.)

Effect of Pitch Distribution.—All variable-pitch propellers in service obtain their pitch variation by turning the blades in the hub to give a different blade angle. It is evident that, if a blade which has been designed so that the angle at any point along the blade gives an advance per revolution which is constant for the propeller, this relation will be disturbed by a rotation of the blade shank in the hub. An increase in the angle of a blade from a setting giving a uniform pitch distribution will result in a pitch that increases progressively from the hub to the tip.

The effects of such a pitch variation along the blade have been investigated. Figure 237 shows two curves run with geometrically similar propellers having adjustable blades. One was run with a propeller having a pitch/diameter ratio of 0.7 for a uniform pitch distribution but with the blades set at an increased angle to give a pitch of 1.5 at a point 75 per cent of the way out from the hub. The other curve was run with a propeller designed to give a uniform pitch of 1.5 for the entire length of the blade. Note that the former propeller gave a higher efficiency up to the value of V/nD for which both curves peaked.

Thus we see that a propeller with a pitch increasing somewhat from the hub to the tip gives a higher efficiency than is obtain-

able with a propeller having a uniform pitch distribution. Test work indicates that, owing to the interference effects of the nacelle behind the engine and the resulting low air velocities near the propeller hub, the pitch gradient along the blade should be low for low blade angles and should increase with increasing blade angle. This is exactly what is obtained with blades that

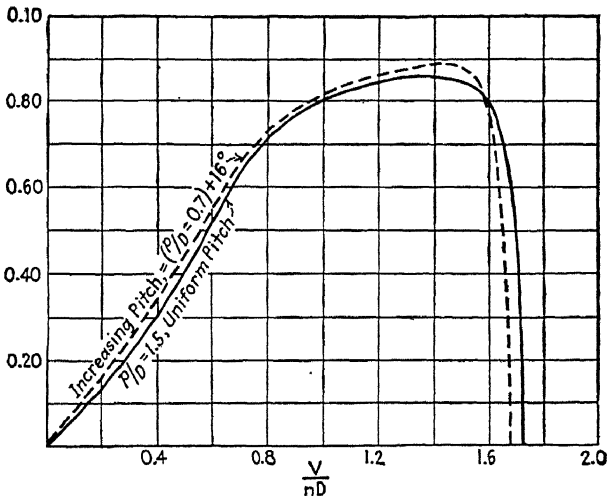

FIG. 237.—Effect of pitch distribution on the efficiency curves for two propellers, one having a uniform pitch from blade shank to tip and the other having a pitch increasing outward from the hub. (Weick, *Aircraft Propeller Design*, 1930.)

can be rotated in the hubs such as we find in all large propellers today. Therefore, the variable-pitch propellers in use give very nearly the same efficiency at any point as a similar fixed-pitch propeller designed specifically for operation at that point.

Effect of Tip Speed.—The velocity of the blade tips along the helical path in which they travel has little effect on the propeller efficiency until velocities approaching the speed of sound are reached. The compressibility effects that then arise greatly increase the power required to drive the propeller and thus reduce the efficiency. Since the propeller tip speed is limited to 1,000 fps and since the propeller diameter must increase with the engine power output, it is evident that the propeller rpm must be decreased as the power output of an engine is raised. This is the reason for the higher reduction-gear ratios used in the larger engines.

Effect of Altitude.—Altitude has two important effects on propeller performance. As indicated by the momentum theory, the decreased air density at altitude results in a loss in propeller efficiency due to the greater velocity that must be imparted to the air stream passing through the propeller to give it the same momentum and hence obtain the same thrust. Air temperature also falls off with increase in altitude. This results in a reduction in the velocity of sound, which in turn causes a decrease in the tip speed at which compressibility losses become serious.

Effect of Blade Thickness.—Blade thickness does not become important until tip speeds of 800 fps or more are reached. In this region, the thicker airfoils begin to lose efficiency at lower tip speeds than the thinner ones because of the fact that the local air velocities at the tip are higher for thick than thin airfoils, other factors being constant. As a result, the tips of a propeller blade are usually made as thin as possible. This is a point in favor of the metal propeller, for metal blade tips can be made thinner than wooden blade tips.

Effect of Body Interference.—In the actual airplane, the propeller generally operates in front of a fuselage or an engine nacelle, which disturbs and slows down the air stream passing through the central portion of the propeller disk. While this may seem undesirable, the actual losses are not so great as they may at first appear. In any actual propeller the hub section is ineffective and offers considerable resistance to the air stream. As a result, although the diameter of the cowling or nacelle behind the propeller is usually nearly half the diameter of the propeller, the losses are much less than the ratio of the two areas would indicate. There are many ways of obtaining the efficiency of a propeller operating in the presence of a body. Perhaps the most logical is to measure the efficiency of the propeller alone and the drag of the body alone and then run the two together, adding the drag of the body when tested alone to the net thrust obtained from the two combined. This is called the *propulsive efficiency*. The efficiency of the whole engine-nacelle unit is called the *net efficiency*. Figure 238 shows a set of curves giving typical values for each of the three efficiencies.

The effect of body interference may be taken into consideration by testing the propeller installed on the fuselage or nacelle. Performance curves may then be drawn up for the installation

on the basis of the test data. Body interference may also be taken into consideration by applying a correction factor. This

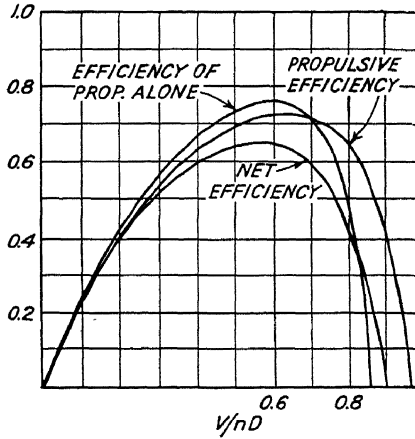

FIG. 238.—Curves for propeller efficiency, net efficiency, and propulsive efficiency for a conventional propeller-nacelle combination. (Weick, *Aircraft Propeller Design*, 1930.)

can be obtained from a curve for the correction factor plotted against the ratio of the body diameter to the propeller diameter.

Effect of the Number of Blades.

Increasing the number of blades increases the amount of power that a propeller of a given diameter can absorb. Figure 239 shows the propeller diameter required for three, four, and six blades plotted against engine power output. The larger number of blades, however, results in interference between the air streams flowing over the blades and causes some loss in propeller efficiency. This loss is small for large propellers.

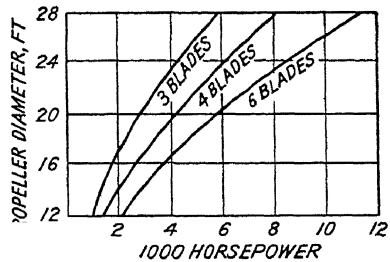

FIG. 239.—Effect of engine power output and number of blades on the propeller diameter required for good efficiency for sea-level operation at 250 mph. (G. T. Lampton, *S.A.E. Trans.*, vol. 33, 1938.)

References

1. WEICK, F. E.: "Aircraft Propeller Design," McGraw-Hill Book Company, Inc., New York, 1930.
2. BAKER, C. F.: Propeller Problems Imposed by Substratosphere Flight, *S.A.E. Trans.*, vol. 33, 1938.

CHAPTER XXVI

PROPELLER CONSTRUCTION AND INSTALLATION

The problems of the testing, manufacture, installation, and maintenance of engines and propellers are closely related throughout the aircraft industry. The basic requirements for the two are similar in many respects. Both must be as light in weight as possible and yet be sufficiently simple and rugged to operate with complete dependability for long periods without attention. As was shown in the chapter on Vibration, the two are so closely coupled that their vibration characteristics must be investigated while they are operating together. Therefore, those working with aircraft engines must be familiar with the construction of aircraft propellers.

PROPELLER BLADES

Wooden Propeller Blades.—All the earlier propellers and most of those now in use in the smaller airplanes have been made of wood. The conventional form of construction is to build the propellers up of laminations about 1 in. thick, with a good glue binding them together. The propeller-blade profile is roughed out and finished according to conventional woodworking practice. The surface is covered with a high-grade fabric partly for protection and partly to carry the torsional loads on the blade. A metal strip is usually riveted to the leading edge. This simple construction results in a relatively inexpensive propeller, especially in cases where only one or two of a given design are desired. But weather imposes severe requirements on propeller blades. When one realizes that the tips of propellers may travel faster than the bullets from most revolvers, it is little wonder that rain, snow, sleet, or hail may reduce a wooden propeller to splinters. Moisture in the atmosphere is another serious factor to be reckoned with, both in connection with the glued joints and in the wood itself.

In addition to the battering that inclement weather may give a propeller, the blades must withstand abrasion, especially near

the tips where the action of dust, sand, and pebbles while the airplane is moving along the ground in take-off or landing is injurious. Routine handling and servicing also result in a certain amount of bumping and nicking. Although inexpensive, light in weight, and having a high vibration-damping factor, the wooden propeller has passed from use on first-line airplanes, largely because of its inability to withstand extreme weather conditions.

Dural Blades.—As larger engines were built and bigger propellers required for them, aluminum, generally in the form of dural forgings, began to be used. Propellers were at first forged in one piece, but die expense was very great. A construction embodying separate blades with round shanks fixed in a steel hub proved to be much more practical. These blades could be adjusted to any desired pitch, and thus a single propeller-blade design could be used for many different airplanes. As a material for large propellers, dural is very desirable. Its uniform strength in all directions, moisture and abrasion resistance, durability, strength-weight ratio, high machinability, and uniformity of material in production make it excellent for the purpose.

Hollow Steel Blades.—Hollow-bladed steel propellers have been made and used for some time. The construction usually followed is to form and machine steel plate to the shape desired for one face of a propeller blade. The upper and lower halves of a blade can be welded or brazed together after forming. Since propeller-blade stresses are high and vibration is severe, it is evident that a virtually perfect weld is necessary, for any slight inclusion or defect in the weld would form the nucleus for a fatigue crack. Such a weld is difficult to obtain in routine production, but it is being done.

As a material, steel is even better than dural if a good weld can be obtained and a hollow-blade construction used, except that the vibration-damping factor is low. This factor makes blade vibration more of a problem. Steel blades are especially resistant to abrasion from sand, small stones, and dust, which is important for military operation from improvised fields. Hollow steel blades have the further advantage that they are somewhat lighter than dural blades in the larger sizes.

Cooling Cuffs.—Short airfoil sections may be placed around the ineffective round shank sections of metal propeller blades to give

improved engine cooling or to increase propeller efficiency in high-speed airplanes. Figure 246 shows a *cooling cuff* installed on a steel propeller blade.

Composition Wood and Plastic Blades.—The Schwarz propeller blade represents a patented type of construction that was originally developed in Europe. The blades are made of thin sheets of veneer that have been impregnated with synthetic resin and bonded together under high pressure.¹ One feature of this construction is that laminations of light soft wood may be used toward the blade tips, while harder and stronger wood can be used in the laminations in the blade shanks. A further strength increase can be obtained by compressing the wood during the molding operation to about one-fourth its normal volume. A metal sleeve is screwed and bonded on the shank of the blade so that it may be mounted in a hub in the same manner as a metal blade. A plastic covering applied to the blade surface and a narrow metal strip placed over the leading edge will increase the durability. This type of blade construction gives a blade of desirable characteristics. The strength-weight ratio is higher than that for dural or steel, and the damping factor of the material is high. According to the manufacturer, the blades are able to withstand snow and rain and even hail and are unaffected by atmospheric-moisture conditions. This type of blade has not come into widespread use at the time of writing, probably owing in part to its relatively recent development.

PROPELLER HUBS

Attachment to Engine.—The problem of the attachment of the propeller to the propeller shaft of the engine has been solved in a number of different ways. A common device used on light-plane engines is a flange made integral with the propeller shaft. A wooden propeller may be bolted directly to this flange. All metal propellers employ splined steel hubs, which engage splines on the propeller shaft.

Propeller-shaft spline dimensions have been standardized, and a number has been assigned to each size by the S.A.E. A No. 20 propeller-shaft spline is generally used on engines of less than 250 hp, a No. 30 spline on engines of 250 to 500 hp, a No. 40 spline on engines of 500 to 1,000 hp, and a No. 50 spline on engines of 1,000 to 1,700 hp. All these have square splines.

Later standards established for shafts suitable for engines of more than 1,800 hp cover the No. 60 spline shaft. This employs involute splines, which have the advantage that they are stronger and less expensive and can be machined to closer tolerances than square splines.

Since splines, especially the square type, do not accurately center a propeller on the shaft, a front and a rear centering cone are normally used. A propeller nut that screws onto the engine

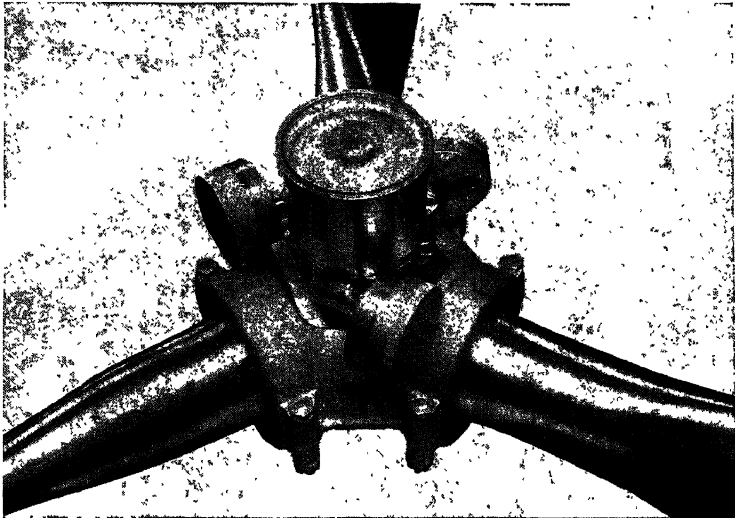

Fig. 240.—The Hamilton Standard constant-speed propeller. (*United Aircraft Corp.*)

propeller shaft is used to draw the propeller up tight on these centering cones. The propeller nut transmits the axial load of the thrust from the propeller to the shaft, while the splines carry the torsional loads. The cones transmit the radial and the bending loads.

PITCH-CHANGING MECHANISMS

Hamilton Standard Constant-speed Propellers.—To meet the demand for a variable-pitch propeller that would give good efficiency for all flight conditions, Hamilton Standard Propellers developed a hydraulically operated propeller that makes use of engine lubricating oil as the hydraulic fluid. The inherent simplicity and reliability of the hydraulic mechanism together

with the ease with which it lent itself to use with a governor helped to make this the first variable-pitch propeller to be widely used.

A Hamilton Standard constant-speed propeller is shown in Fig. 240. The blades are solid dural forgings drilled out at the shanks to fit over a steel *spider* in the hub. Figure 241 shows a spider

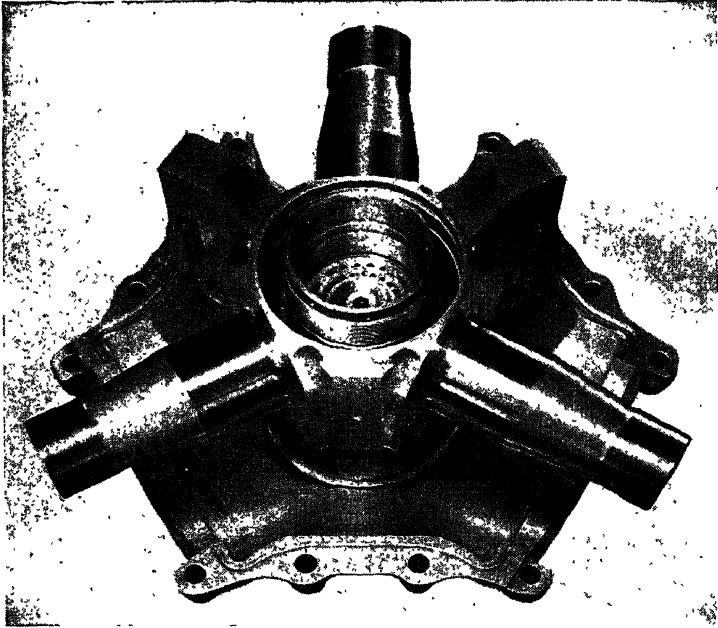

FIG. 241.—Spider and rear half of the barrel of a Hamilton Standard hydromatic propeller. (*United Aircraft Corp.*)

of this type placed inside the rear half of the steel *barrel*, which forms the outer casing for the hub. Two bearings on each arm of the spider carry the bending and most of the thrust loads from the blades, while the radial loads due to the centrifugal force acting on the blades are transmitted into the barrel through a roller thrust bearing. The two halves of the barrel are bolted together to give a simple, rugged assembly. A hole bored through the center of the spider is splined to fit the propeller shaft. Conical seats at either end are provided for the front and rear centering cones.

Brackets attached to the shanks of the blades make it possible to vary the pitch by turning the blades in the hub. Cam slots

are provided in the end of each of these brackets, as shown in Fig. 242. These cam slots are engaged by small bearings and shafts attached to the cylinder, as can be seen in Fig. 240. The action of the bearing on the cam as the cylinder is moved away from the hub causes the ends of the brackets to be displaced, thus turning the blades in the hub. The cylinder is prevented from rotating by the flat surfaces on its sides, which bear against the brackets.

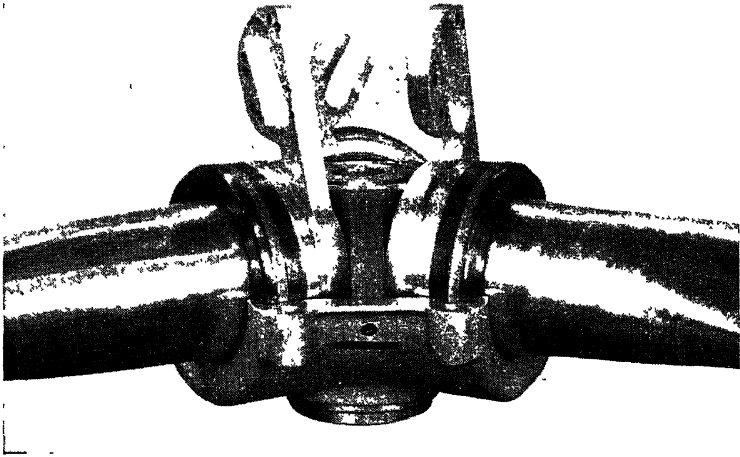

FIG. 242.—Partly assembled Hamilton Standard constant-speed propeller
(United Aircraft Corp.)

A piston contained within the cylinder is made to screw directly onto the propeller shaft. It carries the front centering cones and serves as the propeller nut. A gasket at the front end of the piston seals the clearance between the piston and the cylinder when the latter is installed. A cylinder head closes off the front end of the cylinder.

Oil under pressure may be admitted through the center of the propeller shaft and through the piston to the front of the cylinder, where it acts on the latter to force it forward. The cylinder, in turn, acts on the cam slots to turn the blades toward the low-pitch position. Cylindrical counterweights attached to the outer ends of the brackets on the propeller blades are located somewhat off center so that the centrifugal force acting on them tends to throw the blades into high pitch.

A flyball governor geared to the propeller shaft may be used to control the oil pressure to the propeller piston. If the engine speed drops below that for which the governor is set, the flyballs drop inward. A valve operated by the flyballs opens so that oil will flow to the propeller and cause the blades to turn to a lower pitch. Conversely, if the engine speed becomes greater than that for which the governor is set, the outward movement of the

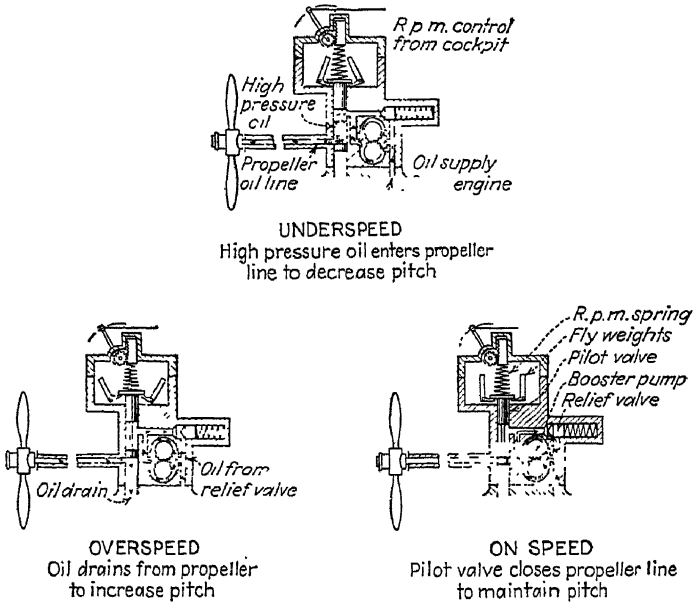

FIG. 243.—Schematic diagrams showing the operation of a Hamilton Standard governor and constant-speed propeller. (United Aircraft Corp.)

flyballs shifts the valve to port oil away from the propeller so that the inertia force acting on the counterweights may turn the blades to a higher pitch. Figure 243 shows a set of schematic diagrams indicating the action of a constant-speed propeller governor. Note that the governor receives its oil from the engine. A small gear pump in the base of the governor boosts the pressure to the value required to operate the propeller.

Hamilton Standard Hydromatic Propellers.—The constant-speed propeller has an inherently small pitch range; *i.e.*, the blades can be turned only 10 or 20 deg. High-performance airplanes have demanded a considerably greater range of blade angles. Further, the safety advantage of a multiengine airplane

in the event of an engine failure is greatly reduced both by the drag of a windmilling propeller and by the severe vibration that might occur if a badly damaged engine were forced by the propeller to continue to rotate. Provision for about 90 deg of blade rotation would permit feathering the blades so that they may be turned edgewise into the air stream. In the feathered position the propeller no longer forces the engine to rotate and

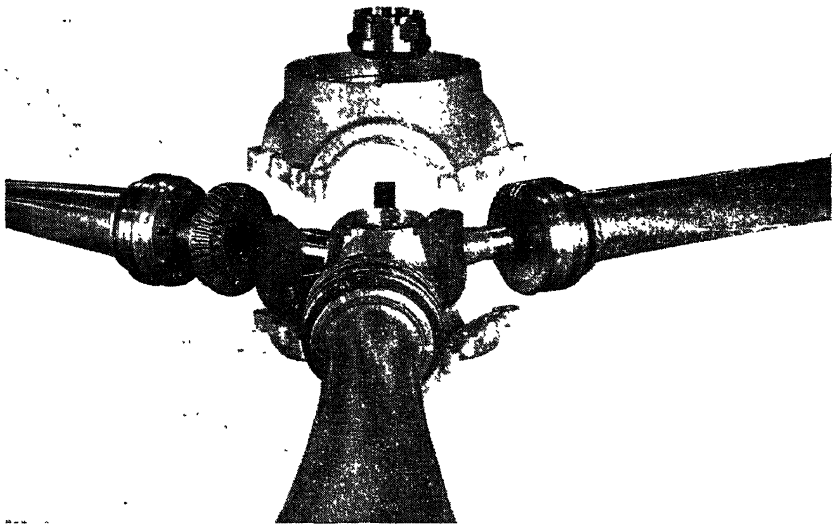

FIG. 244.—Exploded view of the parts in the hub of a hydromatic propeller. (United Aircraft Corp.)

causes negligible drag. The hydromatic propeller was developed to give a greater range of blade angles as well as full feathering operation.

The spider, barrel, and blades of the hydromatic propeller are similar to those for the constant-speed propeller except that blade gears replace the counterweight brackets as a means of turning the blades to a different pitch. Figure 244 is an exploded view of the hub portion and shows the blade gears.

The gear segments on each blade are engaged by a large bevel gear at the inner end of the dome assembly. The pitch-changing mechanism contained in this dome is shown in the exploded view in Fig. 245. The dome is attached to the barrel of the hub by a large ring nut, which is screwed into the threads seen in Fig. 244.

The dome serves as a cylinder in which a piston may move axially under the action of oil pressure. The axial motion of the piston is converted into rotary motion through cam rollers, which act on a cam made integral with the large bevel gear. A stationary cam is also provided to carry the reaction torque from the moving cam. The cam tracks are made with a steep slope at the inner end to give a high mechanical advantage for the blade-angle range of about 35 deg in which the propeller ordinarily operates. The outer ends of the cam tracks have a flatter slope so that much higher oil pressures on the piston are required to move the blades the 45 deg from the normal high-pitch position into the fully feathered position.

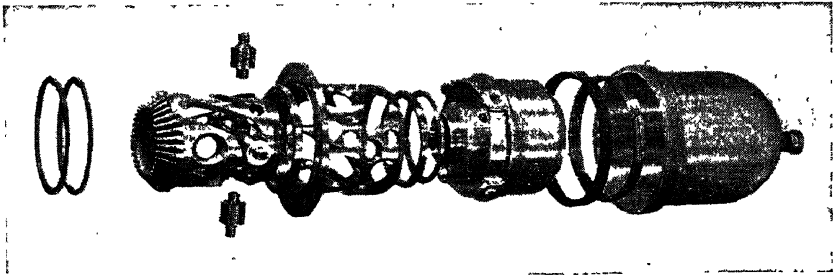

FIG. 245.—Exploded view of the dome assembly from a hydromatic propeller.
(United Aircraft Corp.)

Propeller operation in the normal flight range is with a governor that acts in the manner described for the constant-speed propeller, except that governor oil pressure is supplied to the rear of the piston to turn the blades toward high pitch while the twisting component of the centrifugal forces acting on each blade is used to turn the blades toward low pitch. Since the latter force is not always great enough to provide positive operation, it is supplemented by engine oil pressure acting on the front face of the piston. Feathering operation is obtained by supplying high-pressure oil from an electrically driven auxiliary pump. The pressure from this source should be about 400 psi. The operating force thus made available is sufficient to increase the pitch over the low mechanical-advantage portion of the cam. When the piston has moved forward to the feathered position, the oil supplied from the auxiliary pump cannot escape so that the pressure tends to increase. The increased pressure acts on an automatic switch to shut off the pump. Unfeathering the

propeller may be accomplished by manipulation of a manual control to override the automatic relay. The high pressure that results acts on a distributor valve, which is screwed into the front of the propeller shaft and through which the oil to the propeller flows. Moved by the high oil pressure, the distributor valve shifts to reverse the flow of oil through the passages to the dome and sends the high-pressure oil to the outer

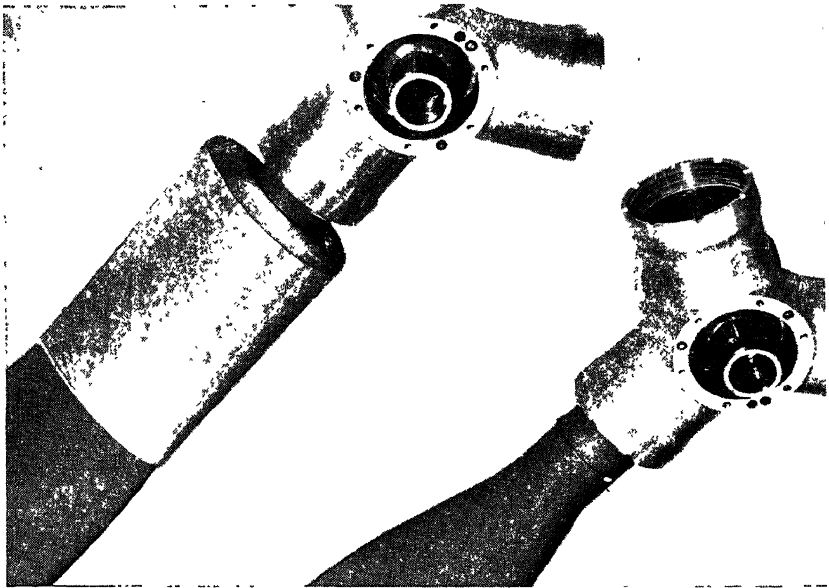

FIG. 246.—Curtiss propeller hubs and blades with and without cooling cuffs installed on the propeller-blade shanks. (*Curtiss Propeller Division, Curtiss-Wright Corp.*)

end of the piston. Driven back by the high oil pressure, the piston unfeathers the blades. When the blades have been unfeathered, the manual control switch on the feathering pump may be released. Release of the oil pressure in the distributor valve allows it to return to its normal position.

Curtiss Electric Propellers.—An electric motor mounted on the propeller hub offers another means of varying the pitch of propeller blades in flight. A Curtiss electric propeller may be seen in Fig. 1. The power unit at the front contains an electric motor which drives a large bevel gear through a planetary-gear system and gives a speed reduction of the order of 10,000 to 1.

This bevel gear drives blade gears in much the same manner as in the hydromatic propeller.

The blades are inserted into sockets in the one-piece steel hub and are held in place by ring nuts with external threads that screw into internal threads in the hub (see Fig. 246). The thrust, bending, and radial loads on each blade are transmitted to the hub through a stack of ball bearings on the blade shank. The ring nut that retains the blade in the hub bears against the outer bearing of this stack (see Fig. 247).

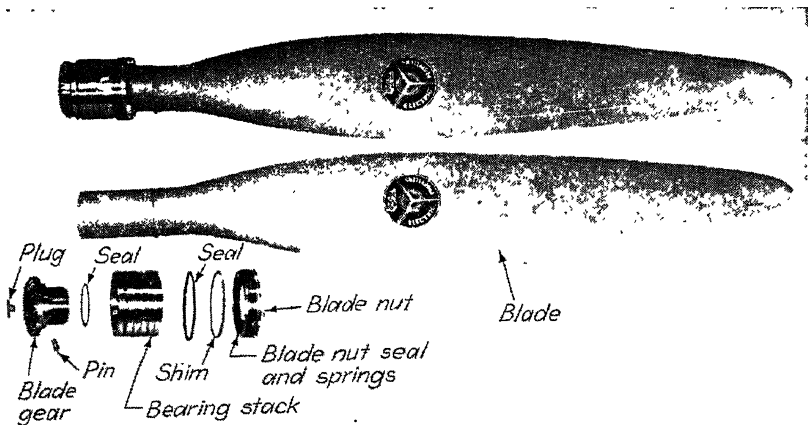

FIG. 247.—Blade assembly for a Curtiss electric propeller. (*Curtiss Propeller Division, Curtiss-Wright Corp.*)

Electric current for the power unit is supplied through four slip rings at the rear of the propeller hub. The front slip ring is for feathering, the second provides a common return, the third is for decreasing the pitch, and the fourth ring is for increasing the pitch. The change in direction of motor rotation is accomplished by using two sets of field coils, each set in series with one of the two rear slip rings. A spring-loaded brake is provided on the motor to lock the armature shaft in position. When current is supplied to the propeller, this brake is pulled back by a solenoid in series with the armature so that it does not interfere with operation of the motor.

The electric propeller has the advantage of greater flexibility of control. It may be controlled by a governor, which will maintain a constant speed at the value set, or a switch may be thrown to permit manual control so that the blades may be set

to any pitch desired. Feathering may be accomplished by tripping a feathering switch. Unfeathering may be accomplished by simply throwing this switch back to the position for normal operation. Figure 248 gives a wiring diagram illustrating the method of operation. Limit switches in the power unit are operated by cams, which move with the power gear. They

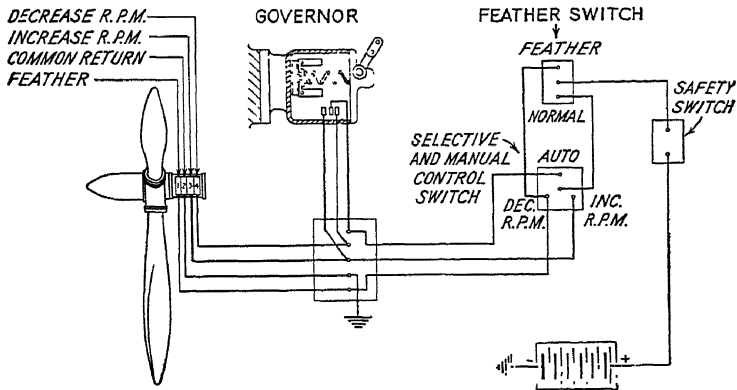

FIG. 248.—Wiring diagram for a Curtiss electric propeller. (Curtiss Propeller Division, Curtiss-Wright Corp.)

act to open the appropriate circuit so that they serve as feathering, high-pitch, and low-pitch stops.

Other Variable-pitch Mechanisms.—A number of other hydraulic, electric, and mechanical mechanisms for varying the pitch of propellers are in use. For information on their operation the student is referred to the service manuals prepared by their manufacturers.

SERVICE PROBLEMS

Icing.—One of the most serious of the service problems that arise in the course of routine operation is icing. If an airplane strikes an air stratum supersaturated with water vapor at a temperature below the freezing point, ice will form rapidly on much of the airplane, including the propeller. Other atmospheric conditions such as sleet storms will also cause icing. The mass of the ice formed on each of the blades will, in general, not be the same and will set up an unbalance, which may cause severe vibration. The condition is greatly aggravated when pieces of ice occasionally break off one of the blades and cause

serious unbalance until the resulting vibration shakes off the ice on the other blades. Theory indicates that centrifugal force and normal blade vibration make it impossible for ice to adhere to the blade beyond a certain radius. Experiments conducted with full-feathering propellers in the field support this and indicate that the ice tends to form almost entirely on the leading edge of the blade.²

The most effective method devised thus far for de-icing propellers has been the use of anti-icing fluid, usually a mixture of alcohol and glycerin. This is discharged through small nozzles at the hub so that the fluid flows out along the leading edge of the blade and spreads over its surface to loosen or prevent any ice formation. Most propellers on airplanes that are to be used in all kinds of weather are fitted with such de-icing equipment.

Nicks and Abrasions.—A certain amount of abrasion of propeller blades caused by sand, pebbles, or other hard particles drawn into the propeller stream during the take-off and struck by the blades is to be expected. Aluminum-alloy and steel blades should be inspected at frequent intervals to guard against the formation of fatigue cracks caused by stress concentrations at these nicks.

In dural propellers, such nicks should be smoothed out with a file and then polished with fine emery paper. An absolute minimum amount of material should be removed, *i.e.*, no more than enough to eliminate sharp corners. The area around the nick may be etched after the repair work to make certain that a fatigue crack has not already begun to form. To do this, a 20 per cent solution of sodium hydroxide should be swabbed on the area in question, allowed to etch the surface for a short time, and then cleaned off with a 10 to 20 per cent solution of nitric acid. During the etching, cracks will be characterized by a collection of fine bubbles, while after etching they will appear as dark lines. Nicks in the outer portion of the blade are by far the most common and ordinarily may be repaired as above. Nicks in the shank are a different matter and should be repaired only by the manufacturer or a qualified agency.

Bent Blades.—Bent metal blades may generally be straightened. This requires special equipment and technique and should be done only by a qualified agency. Steel blades must usually be straightened by the manufacturer. Dural blades with

bends not exceeding 20 deg at 0.15 in. blade thickness to 0 deg at 1.1 in. blade thickness may be cold-straightened by a duly authorized agency. Blades with bends in excess of this amount require heat treatment and should be returned to the manufacturer for repair. Blades bent in edge alignment should not be repaired by anyone except the manufacturer.

Wood Blades.—The covering of wood and composition propellers should be watched for breaks, for such openings may permit the entrance of moisture, with resultant deterioration. In wood propellers in particular, a break in the fabric causes a serious loss in torsional strength, which may be followed by splitting of the wood. Wood propellers should be watched for any indications of such splitting. Though splits progress slowly at first, operation at critical conditions may cause them to progress very rapidly so that a failure may occur in a few hours of operation.

Hub Parts.—The hub parts should be inspected at each overhaul (normally the engine and propeller are overhauled at the same time every 300 to 900 hr). In wooden propellers, the hub bolts should be examined carefully for cracks in the threaded portion and at the fillet beneath the head.

The hub and pitch-changing mechanism of variable-pitch propellers should be inspected for wear and fatigue cracks. Steel parts should be magnafluxed where possible. The races of the ball or roller bearings carrying the blades in the hub should be inspected for pitting or brinelling. The balls or rollers should be examined for cracks. Other parts should be examined for corrosion, wear, etc. If a corrosion-resistant plating such as cadmium is on the parts, it should be inspected. The blades themselves should be inspected for fatigue cracks in the shank. Dural blades may be etched all over to aid inspection. Cracks are particularly likely to occur at the fillet or fillets imposing radial restraint on the blade when in the hub.

Balancing.—After overhaul and reassembly, propellers should be checked for balance. A static-balance test has usually been found to be sufficient. The propeller is mounted on an arbor and placed on a stand so that it is supported by the arbor, which rests on a pair of knife-edges. Any tendency of the propeller to rotate when tested in several different positions should be corrected by the addition of weight according to the manufacturer's directions.

Governor Overhaul.—Propeller governors also require overhaul and inspection. Each part should be examined minutely. After the parts have been inspected, serviced, and reassembled, the whole unit can be adjusted and tested on a special test bench designed for this purpose. The limit stops can be set for the particular application for which the governor is to be used in order to save time in the routine flight test which follows the installation of the overhauled unit in the airplane.

References

1. WEICK, F. E.: Composite Wood and Plastic Propeller Blades, *S.A.E. Trans.*, vol. 34, 1939.
2. BEARD, M. G. and E. W. FULLER: Feathering Propellers in Airline Transportation, *S.A.E. Trans.*, vol. 34, 1939.
3. COLVIN, F. H.: "Aircraft Handbook," 5th ed., McGraw-Hill Book Company, Inc., New York, 1942.

APPENDIX I

TABLES AND CURVE SHEETS FOR INSTALLATION
DESIGN AND TESTING

TABLE IX.—STANDARD ATMOSPHERE DATA*

Altitude, ft	Temperature, °F	Pressure, in. Hg	Specific weight, lb per cu ft	Altitude- density ratio ρ/ρ_0
0	59.00	29.92	0.07651	1.0000
1,000	55.43	28.86	0.07430	0.9710
2,000	51.87	27.82	0.07213	0.9428
3,000	48.30	26.81	0.07001	0.9151
4,000	44.74	25.84	0.06794	0.8881
5,000	41.17	24.89	0.06592	0.8616
6,000	37.60	23.98	0.06395	0.8358
7,000	34.04	23.09	0.06202	0.8016
8,000	30.47	22.22	0.06013	0.7859
9,000	26.90	21.38	0.05829	0.7619
10,000	23.34	20.58	0.05649	0.7384
11,000	19.77	19.79	0.05474	0.7154
12,000	16.21	19.03	0.05303	0.6931
13,000	12.64	18.29	0.05136	0.6712
14,000	9.07	17.57	0.04973	0.6499
15,000	5.51	16.88	0.04814	0.6291
16,000	1.94	16.21	0.04658	0.6088
17,000	-1.63	15.56	0.04507	0.5891
18,000	-5.19	14.94	0.04359	0.5698
19,000	-8.76	14.33	0.04216	0.5509
20,000	-12.32	13.75	0.04075	0.5327
21,000	-15.89	13.18	0.03938	0.5148
22,000	-19.46	12.63	0.03806	0.4974
23,000	-23.02	12.10	0.03676	0.4805
24,000	-26.59	11.59	0.03550	0.4640

*From N.A.C.A. Rept. 216.

TABLE IX.—STANDARD ATMOSPHERE DATA.*—(Continued)

Altitude, ft	Temperature, °F	Pressure, in. Hg	Specific weight, lb per cu ft	Altitude- density ratio ρ/ρ_0
25,000	-30.15	11.10	0.03427	0.4480
26,000	-33.72	10.62	0.03308	0.4323
27,000	-37.29	10.16	0.03192	0.4171
28,000	-40.85	9.72	0.03078	0.4023
29,000	-44.42	9.29	0.02968	0.3869
30,000	-47.99	8.88	0.02861	0.3740
31,000	-51.55	8.48	0.02757	0.3603
32,000	-55.12	8.10	0.02656	0.3472
33,000	-58.68	7.73	0.02558	0.3343
34,000	-62.25	7.38	0.02463	0.3218
35,000	-65.82	7.04	0.02369	0.3098
36,000	-67.00	6.71	0.02265	0.2962
37,000	-67.00	6.39	0.02160	0.2824
38,000	-67.00	6.10	0.02059	0.2692
39,000	-67.00	5.81	0.01963	0.2566
40,000	-67.00	5.54	0.01872	0.2447
41,000	-67.00	5.28	0.01785	0.2332
42,000	-67.00	5.04	0.01701	0.2224
43,000	-67.00	4.80	0.01622	0.2120
44,000	-67.00	4.58	0.01546	0.2021
45,000	-67.00	4.36	0.01474	0.1926
46,000	-67.00	4.16	0.01405	0.1837
47,000	-67.00	3.97	0.01339	0.1751
48,000	-67.00	3.781	0.01277	0.1669
49,000	-67.00	3.60	0.01217	0.1591
50,000	-67.00	3.44	0.01161	0.1517

* From N. A. C. A. Rept. 216.

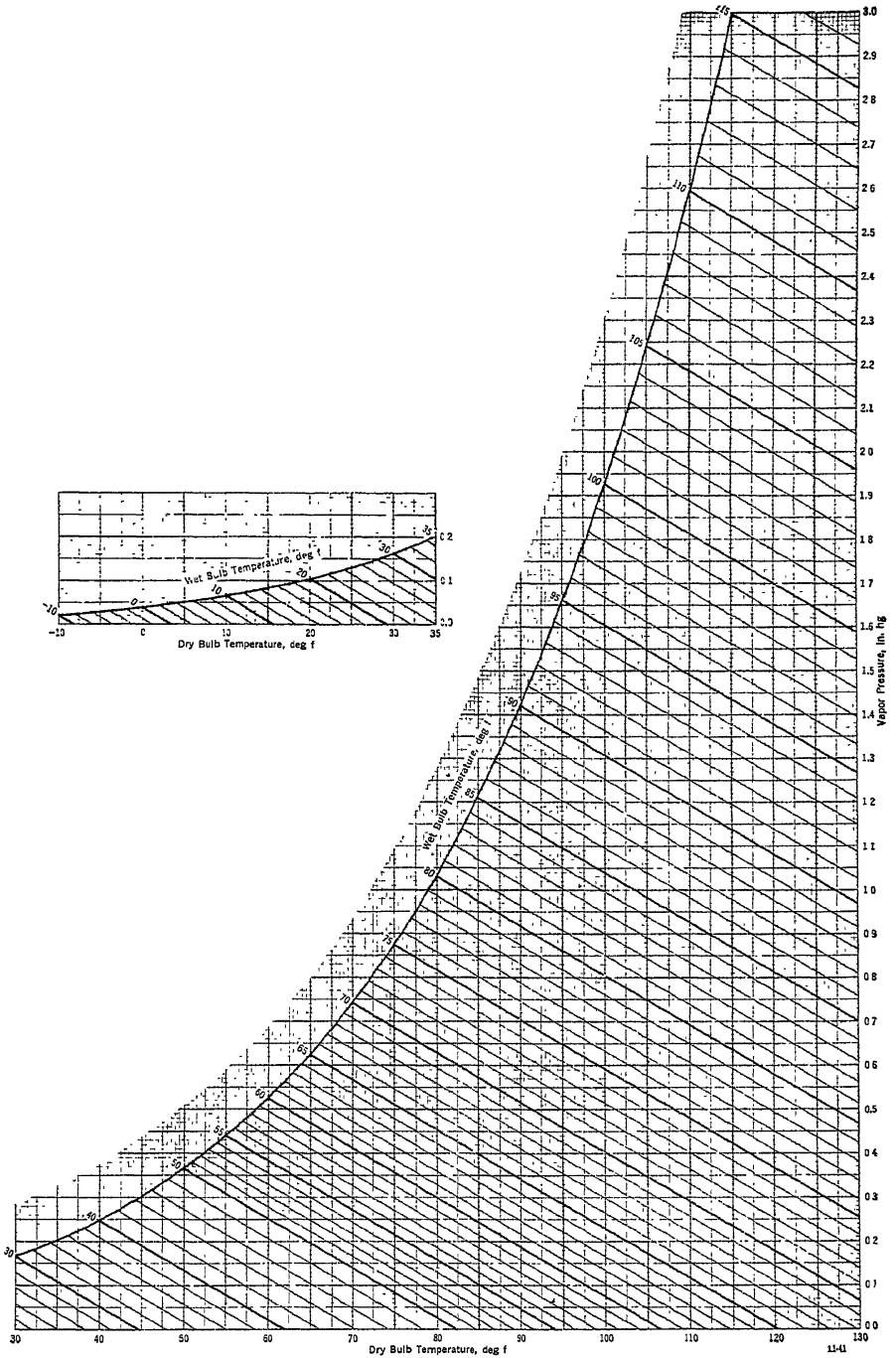

FIG. 249.—Vapor-pressure chart. (S.A.E. Aircraft Engine Test Code.)

TABLE X.—TEMPERATURE CORRECTIONS FOR MERCURY COLUMNS*

Tem- perature of col- umn, °F	Observed reading of column, in. Hg												
	8	10	12	14	16	18	20	22	24	26	28	30	32
	Add												
-20	0.03	0.04	0.05	0.06	0.07	0.08	0.09	0.10	0.11	0.11	0.12	0.13	0.14
-10	0.03	0.04	0.04	0.05	0.06	0.06	0.07	0.08	0.08	0.09	0.10	0.11	0.11
0	0.02	0.03	0.03	0.04	0.04	0.05	0.05	0.06	0.06	0.07	0.07	0.08	0.08
10	0.01	0.02	0.02	0.02	0.03	0.03	0.03	0.04	0.04	0.04	0.05	0.05	0.05
20	0.01	0.01	0.01	0.01	0.01	0.01	0.02	0.02	0.02	0.02	0.02	0.02	0.02
30	0.00	0.00	0.00	0.00	0.00	0.00	0.00	0.00	0.00	0.00	0.00	0.00	0.00
	Subtract												
35	0.00	0.00	0.01	0.01	0.01	0.01	0.01	0.01	0.01	0.01	0.02	0.02	0.02
40	0.01	0.01	0.01	0.01	0.02	0.02	0.02	0.02	0.02	0.03	0.03	0.03	0.03
45	0.01	0.02	0.02	0.02	0.02	0.03	0.03	0.03	0.04	0.04	0.04	0.04	0.05
50	0.01	0.02	0.02	0.03	0.03	0.03	0.04	0.04	0.05	0.05	0.05	0.06	0.06
55	0.02	0.02	0.03	0.03	0.04	0.04	0.05	0.05	0.06	0.06	0.07	0.07	0.08
60	0.02	0.03	0.03	0.04	0.05	0.05	0.06	0.06	0.07	0.07	0.08	0.08	0.09
65	0.03	0.03	0.04	0.05	0.05	0.06	0.07	0.07	0.08	0.09	0.09	0.10	0.10
70	0.03	0.04	0.04	0.05	0.06	0.07	0.07	0.08	0.09	0.10	0.10	0.11	0.12
75	0.03	0.04	0.05	0.06	0.07	0.07	0.08	0.09	0.10	0.11	0.12	0.13	0.13
80	0.04	0.05	0.06	0.07	0.07	0.08	0.09	0.10	0.11	0.12	0.13	0.14	0.15
85	0.04	0.05	0.06	0.07	0.08	0.09	0.10	0.11	0.12	0.13	0.14	0.15	0.16
90	0.05	0.06	0.07	0.08	0.09	0.10	0.11	0.12	0.13	0.14	0.15	0.17	0.18
95	0.05	0.06	0.07	0.09	0.10	0.11	0.12	0.13	0.14	0.16	0.17	0.18	0.19
100	0.06	0.07	0.08	0.09	0.11	0.12	0.13	0.14	0.15	0.17	0.18	0.19	0.20

* From S.A.E. Aircraft Engine Test Code.

This table is computed for columns measured with a brass scale but is applicable with negligible error to measurements with scales of other materials.

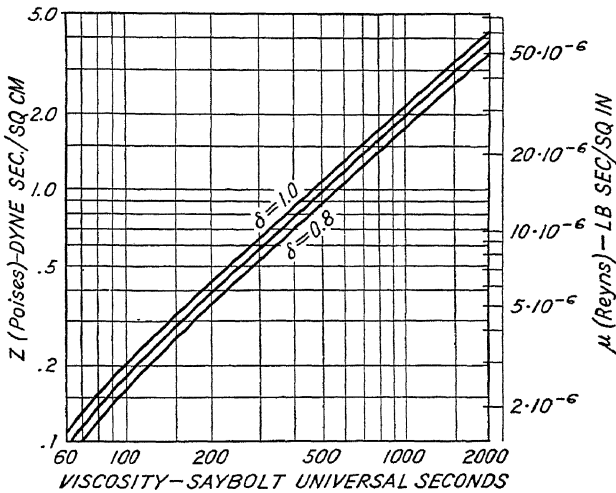

FIG. 250.—Relation between oil viscosity in Saybolt seconds and absolute viscosity. (The Texas Company.)

TABLE XI.—OIL-COOLER DATA*

Core diameter, in.	Frontal area, sq in.	Heat dissipated, Btu per sec	Air flow, lb per sec	Oil flow, lb per sec	Net weight, lb
4	12.57	2.91	.38	.5	8.65
5	19.63	4.70	.58	.5	10.75
6	28.27	6.70	.84	.5	13.30
7	38.48	9.00	1.14	.5	17.10
8	50.26	11.40	1.46	1.0	20.75
9	63.61	15.30	1.89	1.0	24.00
10	78.54	18.50	2.34	1.0	28.25
11	95.03	22.00	2.78	1.0	34.50
12	113.10	26.10	3.31	1.0	38.25
13	132.73	30.60	3.89	1.0	44.75
14	153.94	35.20	4.51	1.0	50.20

* From Young Radiator Co.

NOTE: Heat dissipation based on 100°F temperature difference between average oil temperature and entering air temperature, using U.S. Army A.C. Specification 2-91, Grade 120 oil at 210°F, and a cooling-air pressure drop of 4 in. H₂O.

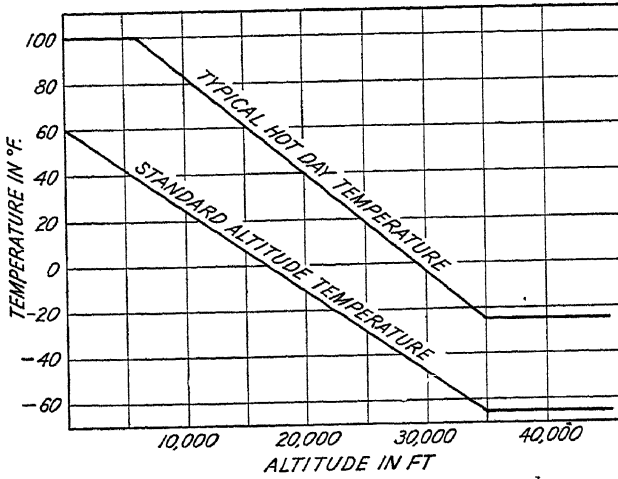

FIG. 251.—Curve showing standard altitude temperature and a curve typical of the several "hot-day" standards in use.

APPENDIX II

LABORATORY INSTRUCTIONS

OPERATION OF A D-C ELECTRIC DYNAMOMETER

The d-c electric dynamometer is an expensive and complex piece of test equipment. It should be handled carefully to prevent expensive damage. The student should be thoroughly familiar with the machine and switch equipment before attempting to operate it. Figure 252 shows a wiring diagram for a typical control panel. To save space at the control bench and to reduce the hazard of accidental contact with the switches, the field rheostat and the push buttons controlling the solenoid-operated switches are usually placed in the control bench and the balance of the panel is removed to a convenient spot in the control room. This makes it possible to start or stop the machine and control the load and speed from the control bench.

The d-c dynamometer may be started and run as a d-c motor. A strong field should be provided for starting; *i.e.*, the field rheostats should be set to the "resistance-out" position. To avoid excessive armature currents, the armature resistance should be set all the way "in."

In changing over from motor to generator operation after the engine has been started, the field resistance should be set all the way "in" after the motor switch has been opened and before the load switch is closed (see Fig. 252). This must be done to prevent stalling the engine and blowing the armature circuit breaker. (Sudden closing of the armature circuit in this way with the armature rotating in a strong field gives an extremely heavy surge of current.)

Owing to the large amounts of inductance in the circuits, the armature and field switches should never be opened unless the respective rheostats are set to the "resistance-in" position, or severe arcing and burning of the switches will occur.

The large torque reactions of the start cause the dynamometer housing to swing through a large arc and are likely to damage

either the dynamometer or the scale linkage. To prevent this, both the dynamometer and the scale should be securely locked in a fixed position before a start is attempted. Detailed instructions follow for the handling of the d-c dynamometer control panel of Fig. 252.

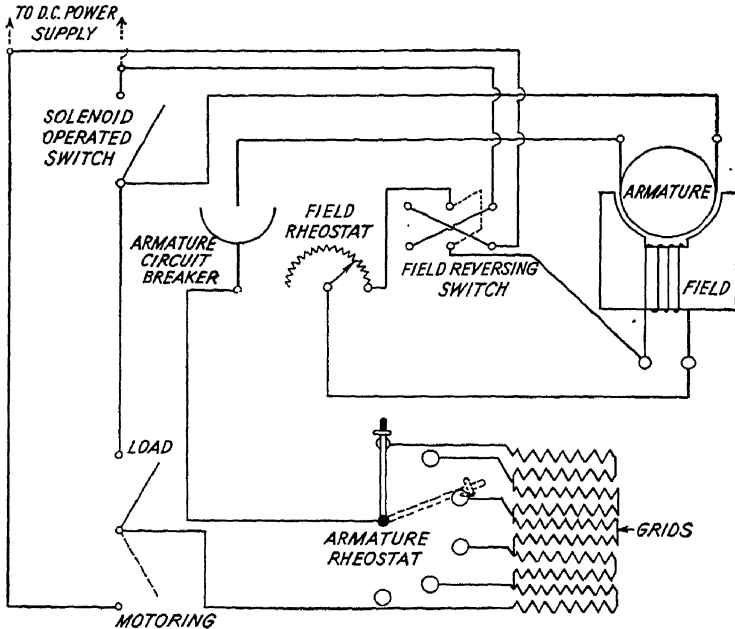

FIG. 252.—Control panel for a d-c electric dynamometer.

If the dynamometer is to be started up and run as a motor, follow the procedure below:

1. Start the M-G set which provides power for starting the dynamometer and adjust the voltage. Make sure that the dynamometer and scale are locked.
2. Set the armature resistance all the way "in" and the field resistance all the way "out."
3. Close the field switches to give the desired direction of rotation.
4. Close the armature circuit breaker.
5. Close the main switch to the motoring position.
6. Press start button to close solenoid-operated motor switch.
7. When the dynamometer has come up to speed and has stabilized, cut out the armature resistance; *i.e.*, turn the armature

rheostat to the resistance-out position. This will cause some increase in speed. The speed can then be controlled with the field rheostat.

8. The dynamometer can be stopped by pressing the stop button. It should be idled down first except in emergencies.

9. If the dynamometer is to be operated as a generator, the first six steps given above can be used to start motoring the engine. Then proceed as follows:

- a. When the engine has come up to speed after starting the dynamometer, turn on the fuel. Then turn on the engine ignition switch.
- b. When the engine is idling smoothly, press the stop button to open the motor switch. Turn the field resistance to full "in" position. Open the main switch from motoring position, and close the load switch. Set the armature resistance to the full "out" position.
- c. Unlock the dynamometer and scale. Control the speed and load with the field resistance.
- d. The engine can be stopped at any time by moving the mixture control to the cutoff position or by turning off the ignition.
- e. When the engine has been stopped, lock the dynamometer and the scale.

ENGINE TEST LOG SHEETS

Log sheets such as that shown in Fig. 253 are taken to provide a chronological record of all aircraft-engine tests. These original log sheets are then bound in books to provide a source of information which may be used later for many different purposes other than that for which they were primarily intended. Partly because of this, it is important that a complete set of test data be included on the log sheet.

1. Before starting, fill in all engine and test data in spaces at the top of the data sheet, including the type of test being run. Additional information can be added at the bottom of the sheet if necessary.

2. The time, rpm, and oil pressure should always be recorded on a separate line each time the engine is started. Any changes made in the engine or test setup since the last stop should be noted on the same or previous lines.

9. The various columns of data should be grouped as logically as possible. If a number of manometers are to be read, they should be grouped together. This also applies to thermocouples, etc.

10. All data should be taken as nearly simultaneously as possible. Where fluctuation in a manometer or scale makes reading

TEST CODE - LOG SHEET - AC De:

LABORATORY **GUGGENHEIM SCHOOL OF AERONAUTICS, N.Y.U.** TEST STAND & EQUIPMENT ENGINE

NATURE OF TEST **CALIBRATION** Stand No. 1 Model 15

SAE Vis. 60 Engine Mount R16D Weight (with acc.) 1.261

Oct No. 82 Cooling System BLOWER Model

Prop. Mfr. Blade Design No.

Serial Dyn Const. 3000

Hub Design No. Torque Meter Const.

Orific Diam. No.	Flow Lb./ hr.	Temp. °F.	Temp. °F.	Temp. °F.	Temp. °F.	Temp. °F.	Flow GPM	Circ. In.	Circ. In.	Temp. In deg. F.	Temp. Out deg. F.	Drain Cup In. H ₂ O	MANIFOLD PRESSURE											
													CYLINDER BEARS											
													1	2	3	4	5	6	7	8	9	#7 Cyl Bkck	#7 Cyl Bkck	
	58						24			91			+30 263	272	282	313	238	309	186	264	288	188	157	+17
	60	100	107	7			22			91			+30 244	256	262	298	228	296	192	260	272	184	170	+17
	60	108	113	5			22			91			+30 245	268	276	301	236	310	201	276	292	187	174	+17
	60	114	119	5			22			91			+30 280	292	298	328	257	348	224	299	328	198	179	+17
	60	116	121	5			22			91			+30 286	298	306	338	260	352	230	298	324	208		+22
	60	118	122	4			22			91			+40 296	308	314	347	269	363	270	304	338	203		+22
	60	119	123	4			22			91														
	50						22																	
	61	119	124	5			21.75			91			+20 254	260	276	307	252	288	242	280	294	190	188	+13
	61	121	128	7			21.75			92			+20 312	320	337	383	292	377	308	322	351	216	216	+13
	61	124	130	6			21.75			93			+25 346	359	363	395	324	424	352	364	378	230		+17
	60	126	132	6			21.75			94			+50 374	366	400	370	436	356		360	230			+23
	62	130	139	9			21.50			95			+50 266	314	308	325	260	334	302	290	298	212		+33
	61	133	142	9			21.50			94			+50 242	308	303	318	253	338	314	294	302	206		+33
	61	134	143	9			21.25			94			+50 273	324	314	339	271	362	338	322	350	210		+34
	60	135	144	9			21.00			95			+50 282	350	344	378	307	416	367	350	360	225		+34

Representatives [Navy]

TAYLOR, FORD,
FASELER, ALLE

an aircraft-engine test.

difficult, a mean value should be taken unless experience dictates otherwise.

11. All manometer readings should be recorded as plus or minus with respect to atmospheric pressure.

12. Log sheets should be neat, complete, and accurate. The man recording data should be alert at all times to catch inconsistencies. Erratic behavior of the manifold-pressure manometer, impossible specific fuel consumptions, etc., should be investigated immediately and the cause determined.

PREPARATION OF CURVE SHEETS

1. Each curve sheet should have a title block giving the essential information peculiar to the curve. The title of the curve should be in large-size capital letters, the balance in smaller size letters, either capital or lower case. It may often be desirable to segregate engine data and test data, separating those peculiar to the engine from those belonging to the test.

2. Scales should be so selected that the independent variable is read along the abscissa (horizontally) and the dependent variable on the ordinate (vertically).

3. Title blocks, legends, and other tabulated information should never be placed between a curve and the coordinate scales to which the person using the curve must refer.

4. Where a number of dependent variables are plotted against a single independent variable, the scales should not be placed so that the various curves fall on top of each other. Instead, each curve should have its own region on the graph sheet, as was done in Fig. 63, for example.

5. The range covered on the scale should not be larger than is required by the values of the data and should always give sufficient "spread" to the points to give prominence to the characteristics desired. In some cases, care must be taken to avoid the use of a scale that will magnify the inherent experimental error to give an unreasonable "scatter" of the points.

6. Scale divisions should always be even decimal parts of 10 to facilitate reading, except in unusual cases where special considerations dictate otherwise.

7. Where curves are based on experimental data, points should be plotted so that they show up clearly. Small circles or other symbols should be used for this purpose.

8. If more than one curve is plotted on any given set of coordinates, different symbols should be used for each curve. A legend indicating the significance of each symbol should be provided.

9. It is desirable to plot curves on paper suitable for making blueprints so that copies may be made easily and quickly.

INDEX

A

Accelerating pump, 119
Acceleration, piston, 182
Accessories, 398
Accessory-drive gear box, 15, 400
Accessory-drive shaft, 31
Afterfiring, 59, 153
Air bleed, 120
Air box, 137
Air consumption, 352
Air flow, relation to horsepower, 86, 352
Air scoop, drag, 339
 effect of, on carburetor, 342
Alkylation, 204
Allison engine, 16, 37, 71, 232
Altitude, critical, 98
 density ratio, 92, 451
 effect of, on carburetion, 118
 on cylinder-head temperature, 169
 on fuel system, 371
 on ignition system, 148, 410
 on oil system, 242, 394
 on power output, 92
 on propeller efficiency, 423, 434
Analyzer, exhaust gas, 404
Antiknock, 202
 (See also Detonation)
A.P.I. degrees, 220
Aromatics, 197, 201
Articulating rod, 21
Atmosphere, standard, 101
 correction to, 101
 table for, 451

B

Backfiring, 46, 87, 352
Baffle pressure drop, 165, 312

Baffle pressure drop, available, 315
 effect of, on cylinder-head temperature, 168
 required, 168, 314
Baffles, cooling air, 162, 323
Balance, 179
 aerodynamic, 188
 dynamic, 179
 engine, 181
 inertia, 180
 propeller, 188, 449
 static, 179
Balancer, harmonic, 24, 186
Barrel engine, 10
Basic metering head, 117
Battery-coil ignition system, 140
Bearing, friction, 225, 238
 journal, 24
 lubrication, 226
 main, 24
 master rod, 24, 225
Bellmouthing, 254
Benzene, 201
Best economy mixture, 109
Best power mixture, 109
Blast tubes, 325
Blowdown, exhaust, 363
Blower (see Supercharger)
Blower cooling, 323
Blower ratio, 96
Boost, 56
 (See also Manifold pressure)
Booster coil, 146
Booster magneto, 146
Booster pump, 442
Breather, 237, 388
Breathing, 236
Brinelling, 252, 449

- C
- Cable stands, 263
- Cam, 30
- Campini propulsion system, 334
- Capacity, power, 85
- Carbon deposits, 250
- Carbon residue, 222
- Carburetion, effect of air scoop, 342
 effect of altitude, 118
 requirements, 115
- Carburetor, 116
 air box, 137
 air-duct design, 345
 air filter, 348
 air heat, 346
 air-heater valve, 347
 altitude compensation, 129
 float type, 120
 Holley, 124
 icing, 123
 idle systems, 122, 126, 131, 134
 load compensation, 129
 master, 136
 metering head, 117
 simple, 116
 Stromberg, 120, 131
- Chafing, 246
- Combustion, 57
 detonation, 60
 normal, 57
 photographs, 61
 preignition, 56
 pressure, 54
 pressure development, 58
 products of, 52
 temperature, 54, 158
 time, 52, 57, 60
- Compression ratio, 50
 effects, 51, 64
 measurement, 55
 variation in knock testing, 64
- Connecting rod, articulated, 21
 fork and blade, 39
 master, 21
 true motion, 182
- Constant bmep curve, 277
- Constant-power mixture-control
 curve, 107, 277
- Controls, 288
 automatic, 407
- Coolant, 7, 334
 air, flow of, 164
 liquid, flow of, 165
 systems, liquid, 170, 327
 temperature, effect, 170
- Cooling, 156
 air flow, 164
 available, 314
 baffles, 162, 323
 basic heat transfer, 156
 blower, 323
 cuffs, 317, 438
 drag, 308, 311, 318
 effect of spinner, 317
 effectiveness, intercooler, 356
 evaporative, 329
 fins, 161
 ground, 316
 liquid, 165, 170, 327
 power loss, 318
 required, 312
- Corrosion, 246
 exhaust valve, 248
 fretting, 248
- Counterweight, 22, 183
- Cowling, 307
 air flow around, 307
 attachment, 324
 drag, 308
 exit slots, 319¹
 in-line engines, 322
 inner, 325
 N.A.C.A., 307
 pressure distribution, 314, 316
- Cracking, 203
 catalytic, 204
- Crankcase, 20, 38
 front section, 20
 main, 20
 rear section, 31
- Crankcheek, 22
- Crankpin, 22
- Crankshaft, 22, 39
 torque variation, 184

- Crankshaft, vibration, 175
 Critical altitude, 4, 98
 Cuno oil strainer, 232
 Curve sheets, preparation of, 461
 Cycle, 47
 actual, 50
 air, 48
 four stroke, 45
 fuel-air, 49
 ideal, 48
 two stroke, 47
 Cycloparaffins, 201
 Cylinder, 25
 arrangement, 8
 blocks, 37
 construction, 25, 37
 deck, 20
 numbering of, 19
 size, effect of, on detonation, 68
 on power output, 55
 Cylinder-head temperature, 170
 allowable, 156, 312
 effect of altitude, 169
 effect of baffle pressure drop, 166
 effect of detonation, 170
 effect of fuel-air ratio, 167
 effect of power output, 167
 effect on heat rejection, 159
- D
- Damper, dynamic, 186
 friction, 186
 Damping, vibration, 172, 437
 Deflection unbalance, 183
 Degrees A.P.I., 220
 Demulsibility, 220
 Deposits, combustion chamber, 253
 engine, 253
 Detergent, 205
 Detonation, 60
 effect of, on exhaust flames, 279
 effect of, on head temperature, 170
 effect of combustion-chamber deposits, 69
 effect of combustion-chamber size, 68
 effect of compression ratio, 64
 effect of fuel, 68, 202
 effect of head temperature, 67
 effect of manifold air temperature, 67
 effect of rpm, 66
 effect of spark advance, 65
 effect of test methods, 205
 effect of tetraethyl lead, 210
 effects, 62, 170
 limitations imposed, 63, 212
 suppressants, 209
 Dewaxing, 204
 Diesel, 6, 16
 Diffuser, 32, 34, 74, 79
 Dilution, oil, 395
 Distillation, 203
 test, 214
 Distribution, 213
 effect of supercharger, 72
 Distributor, 141
 Dive test, 261
 Doctor test, 217
 Drag, cooling, 308, 311
 cowling, 308
 form, 308
 internal, 308
 Dry air pressure, 102
 Dry lubricants, 224
 Dynamic balance, 179
 Dynamic damper, 186
 Dynamic suspension, 305
 Dynamometer, construction, 272
 operation, 272, 457
 stands, 264
 types, 272
- E
- Efficiency, mechanical, 56
 propeller, 422, 426, 429
 supercharger, 77
 thermal, 56
 volumetric, 56
 End float, 44
 Engines, in-line, 8, 42
 opposed cylinder, 13, 15, 40
 opposed piston, 17

- Engines, radial, 9, 11, 19
 sleeve valve, 12, 29
 types, 6, 18
 Vee, 9, 16, 37
 X, 9
- Evaporative cooling, 329
- Exhaust back pressure, effects of, 361
- Exhaust blowdown, 363
- Exhaust collector ring, 361
 support, 366
- Exhaust flames, 279
 significance, 279
- Exhaust gas, analyzer, 404
 composition, 53
 residual, 50
 temperature, 158
- Exhaust stacks, 268, 279, 360
- Exhaust systems, 360
 clearance requirements, 369
 exit openings, 369
 materials, 370
 size requirements, 368
 test stand, 268
- Exhaust turbosuperchargers, 99, 362
 installation, 363
- Exit slot, cowling, design, 319
 nose, 321
- Expansion tank, 327, 336
- F
- Failures, part, 248
- Fatigue cracks, 249
- Feathering, piston ring, 244
- Feathering propellers, 442, 445
- Feathering pump, 444
- Filter, carburetor air, 348
 dry, 349
 viscous impingement, 349
- Filter, fuel (*see* Fuel strainer)
- Filter, oil, 232, 396
- Fins, cooling, 161
- Fire-extinguishing system, 287
- Fire hazard, 374, 383
- Fire point, 222
- Flame front, 58
- Flash point, 222
- Floating power, 301
- Foaming, oil, 220, 393
- Fractionation, 203
- Friction, 225
 boundary, 225
 dry, 225
 fluid, 225
 horsepower, 111
- Front end, 19
- Fuel, 195
 antiknock characteristics, 202
 aromatic, 197
 boiling point, 214, 216, 372, 374
 knock rating, 170, 205
 low-volatile, 223, 375
 minimum starting temperature, 215
 naphthenic, 197
 octane rating, 170, 205
 olefinic, 197
 paraffinic, 197
 physical properties, 196, 216
 safety, 223, 375
 specifications, 217
 structure, 200
 volatility, 213
- Fuel-air ratio, 53
 best power, 108
 best economy, 108
 chemically correct, 53, 108
 effect of, on cooling, 161, 312
 on engine operation, 107
 on fuel consumption, 108
 on peak pressure, 53
 on peak temperature, 53
 on power output, 104, 108
- Fuel consumption, 56
 brake specific, 56, 113
 indicated specific, 56, 110
 propeller load, 111
 specific, 56, 113
- Fuel gauges, 382
- Fuel injection, 36
- Fuel lines, 381
 pressure drop, 381
- Fuel pumps, 376
 booster, 378
- Fuel strainers, 382

Fuel systems, 371
 layout, 383
 Fuel tanks, 378
 bullet-sealing, 379
 construction, 378
 integral, 378
 location, 378
 pressurized, 375
 weight, 380
 Full-throttle curve, 89

G

Galling, 246
 Gas, exhaust (*see* Exhaust gas)
 Gasoline, cracked, 203
 straight run, 203
 (*See also* Fuel)
 Gear, reduction, 33
 Gear box, accessory drive, 15, 400
 Gears, lubrication of, 230
 Generators, 400
 Glycol, 327, 334
 boiling point, 328
 freezing point, 328
 (*See also* Coolant systems;
 Cooling)
 Governor, propeller, 407, 442
 Greases, 223
 Green run, 259
 Guides, valve, 26
 Gum, 204, 215
 Gun synchronizers, 401
 Gyroscopic forces, propeller, 188

H

Heat rejection, to coolant, 158
 effect of cylinder-head temperature, 159
 effect of fuel-air ratio, 161
 effect of power output, 159
 liquid, 165
 to oil, 239
 effect of crankcase cooling, 240, 288
 effect of oil inlet temperature, 240
 effect of power output, 240

Heat transfer, basic, 156
 effect of air velocity, 164
 Heat-transfer coefficient, 157
 Heater valve, 347
 Heptane, 205
 Horizontally opposed engine, 15, 40
 Horsepower, brake, 55
 correction of, 101
 friction, 55, 111
 indicated, 55
 (*See also* Power output)

Housing, 20
 Hydrocarbons, 197
 Hydrogenation, 200

I

Icing, carburetor, 123
 conditions causing, 340
 induction system, 340
 propeller, 447
 Idle cut-off, 120
 Idle enrichment, 119
 Idle systems, 122, 126, 131, 134
 Ignition, 139
 battery coil, 140
 harness, 147
 magneto, 141
 shielding, 147
 spark effectiveness, 139
 switch, 141
 trouble shooting, 154
 wire, 147
 Immersion heaters, 396
 Impulse coupling, 147
 Induction systems, 338
 standard symbols for pressures
 and temperatures, 351
 Installation, airplane, 282
 accessibility requirements, 290
 components, 285
 weight, 289
 layout, 286, 288
 submerged, 296
 test stand, 275
 Intake pipes, 21, 30
 Intensifier tube, 346

- Intercooler, 352
 cooling effectiveness, 356
 effect of mass-flow ratio, 355
 effect of size, 359
 effect of tube length, 354
 performance chart, 357
 selection, 356
- Isomer, 199
- Iso-octane, 200
- J
- Jet propulsion, exhaust, 364
- Journal, 22, 24
- Junk head, 29
- Junk rings, 30
- K
- Knock (*see* Detonation)
- Knuckle pin, 21
- L
- Lead, tetraethyl, 209
- Lead corrosion, 247
- Lead susceptibility, 211
- Link rod, 21
- Liquid-coolant systems, 327
- Liquid-cooled engines, 37
 cooling characteristics, 170
- Load compensation, 129
- Log sheets, test, 459
- Lubricants, 195
 dry, 224
 greases, 223
 testing of, 217
- Lubricating systems, 231, 237, 386
- Lubrication, 225
 ball and roller bearing, 231
 effect of surface roughness, 228, 230
 effect of viscosity, 228, 229
 gear, 230
 hydrodynamic theory, 227
 sleeve bearing, 226
- M
- Magneto check, 153
- Magneto construction, 142
- Magneto ignition system, 141
- Main bearings, 25
- Manifold, exhaust, 367
 inlet, 40
- Manifold absolute pressure, 56
- Manifold pressure, 56
 effect on power, 54, 72, 90
 regulators, 407
- Master rod, 21, 22
- Mean gas temperature, 157
- Mechanical efficiency, 56
- Metering head, 117
- Michelled washer, 229
- Mixture, best economy, 108
 best power, 108
 chemically correct, 108
- Mixture control, 120
- Mixture-control curves, 107
 constant power, 109, 277
 constant throttle, 108
- Mounting lugs, 21
- Mounts, 298
 construction, 299
 in-line engine, 300
 radial engine, 299
 vibration isolation, 301
- N
- Naphthenes, 197, 201
- Neutralization number, 221
- O
- Octane, 200
 number, 205
 rating, 205
- Oil consumption, 254, 391
- Oil cooler, 388
 data for, 455
- Oil cooling, 231
- Oil dilution systems, 395
- Oil flat, 229

- Oil flow, 237
 - effect of inlet temperature, 238
 - effect of pressure, 237
 - effect of rpm, 237
 - Oil groove, 228
 - Oil inlet temperature, effect of, on
 - cooler size, 240
 - on heat rejection, 240
 - on oil, 195, 218, 241
 - on oil flow, 238
 - Oil lines, 393
 - pressure drop in, 394
 - Oil pressure, 232, 234
 - fluctuation of, 394, 412
 - relief valve, 231, 237
 - Oil pump, 231
 - Oil separators, 397
 - Oil sludge, 222, 223, 255, 393
 - Oil systems, 386
 - filters, 396
 - gauges, 396
 - layout, 386
 - starting provisions, 395
 - temperature regulation, 390
 - vents, 388, 395
 - warm-up provisions, 395
 - Oil tanks, 391
 - hopper type, 392
 - size requirements, 391
 - Oil temperature rise, 238
 - Oiliness, 230
 - Oils, 195
 - asphalt base, 197
 - paraffin base, 197
 - physical and chemical tests, 217
 - viscosity, 217
 - Olefins, 197, 200
 - Oxidation number, 222
- P
- Paraffins, 197
 - Peak pressure, 56
 - Performance charts, engine, 91, 3, 95
 - Petroleum refining, 203
 - cracking, 203
 - distillation, 203
 - Petroleum refining, flow sheet, 205
 - fractionation, 203
 - solvent extraction, 204
 - Pick-up, 246
 - Piston, 26
 - acceleration, 182
 - Piston displacement, 55
 - Piston pin, 26
 - Piston rings, 27
 - feathering, 244
 - scuffing, 244
 - seating, 245
 - types, 27
 - wear, 245
 - Pitting, 251
 - Polymerization, 204
 - Ports, exhaust, 26
 - intake, 26
 - valve, 26
 - Pour point, 220
 - Power, correction, 101
 - cruising, 4
 - limitations on, 88
 - rated, 4
 - take-off, 3
 - Power capacity, 85
 - effect of altitude, 92
 - Power enrichment, 119
 - Power loading, 3
 - Power output, 55
 - effect of air flow, 86
 - effect of altitude, 92
 - effect of atmospheric conditions, 101
 - effect of compression ratio, 50
 - effect of cylinder-head temperature, 105
 - effect of exhaust back pressure, 361
 - effect of fuel, 195, 212
 - effect of fuel-air ratio, 53, 104, 108
 - effect of humidity, 102
 - effect of manifold pressure, 54, 72, 90
 - effect of octane number, 212
 - effect of piston displacement, 55
 - effect of ram, 338
 - effect of rpm, 87

- Power output, effect of spark timing, 50
 effect of supercharger, 54, 71, 87, 96
 effect of valve timing, 51
 effect of wear, 106
 full throttle, 89
 limitations on, 63, 88, 212
- Power-plant unit, 294
- Power-recovery test stand, 266
- Power section, 35
- Pratt and Whitney engines, 11, 14, 23, 26, 33, 34, 35
- Precipitation number, 220
- Preignition, 59
- Preignition rating, 153
- Pressure, boost, 56
 brake mean effective, 55
 indicated mean effective, 56
 intake manifold, 56, 76, 90
 mean effective, 55
 oil, 232
 peak, 56
- Pressure coefficient, 77
- Pressure drop, air effect of density, 118
 fuel, 381
 oil, 394
- Prestone (*see* Glycol)
- Priming systems, 138
- Propeller blade, angle, 421
 cuff, 438
 shank, 421
 tip, 421
- Propeller coefficients, 427
 effective pitch ratio, 427
 power, 429
 progression factor, 427
 speed-power, 429
 thrust, 428
- Propeller diameter, 421
- Propeller efficiency, 422, 426, 429
 effect of airplane speed, 423, 432
 effect of altitude, 423, 434
 effect of blade angle, 431
 effect of blade thickness, 434
 effect of body interference, 434
 effect of diameter, 423
- Propeller efficiency, effect of number of blades, 435
 effect of pitch distribution, 432
 effect of thrust, 423
 effect of tip speed, 433
 ideal, 423, 426
 net, 434
 propulsive, 434
- Propeller icing, 447
- Propeller inspection, 449
- Propeller pitch, 422
 effective, 422
 geometric, 422
- Propeller servicing, 448
- Propeller shaft, 35
 extension drive, 296
 spline designations, 438
- Propeller theory, 422
- Propellers, balancing, 449
 construction, 436
 Curtiss, 445
 electric, 445
 Hamilton Standard, 439
 hydromatic, 442
- Pumps, feathering, 444
 fuel, 376
 governor, 442
 hydraulic, 400
 oil, 231
 vacuum, 400
 wobble, 377
- Push rod, 30
- R
- Radiator, 330
 coolant, 335
 glycol, 335
 heated duct, 331
 location, 335
 oil, 389
 thrust, 330
- Ram, 102, 338
- Ranger engines, 43, 284
- Rear, 21
 Rear cover, 19
 Rear section, 21
 Rear supercharger housing, 20
- Reduction gear, 33
 torque meter, 401

Reference fuel, 212
 Reid vapor pressure, 215
 Rings, hydro transfer, 34
 piston, 26
 side clearance, 254
 Rocker arm, 26, 30
 Rocker bearing, 30
 Rocker bolt, 30
 Rocker box, 26
 Rods, connecting, 21, 39, 182
 Rough operation, 59, 72, 109, 154
 Run-in, 259
 Run-out, 260

S

Safety fuel, 223, 375
 Saybolt universal seconds, 218
 Scavenge pump, 234
 Scavenging, 234, 241
 Scoring, 245
 Scuffing, 244
 Scupper, 395
 Seizing, 246
 Sleeve valve, 12, 29
 Sludge, 222, 223, 255, 393
 Sniffer valve, 327
 Solvent extraction, 204
 Spark advance, 47, 65
 Spark effectiveness, 139
 Spark over, 149
 Spark plug, 150
 ceramic, 150
 fouling, 151, 153
 gap, 139
 mica, 150
 misfiring, 152
 testing, 153
 Spark timing, 47
 effects, 47, 65, 66
 Spline, propeller, 35, 438
 Springs, valve, 29
 Starter shaft, 31
 Starters, 398
 Starting procedure, dynamometer,
 457
 engine, 276
 test stand, 275
 Stopping procedure, 278
 Stroke, 55

Sump, 35, 42
 dry, 231
 wet, 231
 Supercharger, 72
 auxiliary stage, 99
 ductwork, 350
 installation specifications, 352
 weight of, 289
 coefficients, 77
 density, 79
 load, 79
 pressure, 77
 pressure ratio, 77
 temperature, 78
 effect on power output, 54, 71, 73, 98
 efficiency, 77
 exhaust turbo, 99, 350, 362
 gear-driven, 96, 350
 power input, 75, 77
 pressure rise, 73
 single stage, 96
 surging, 82
 temperature rise, 76, 83, 358
 two speed, 96, 98
 two stage, 98
 Surging, 82
 Synchronizers, gun, 401
 propeller, 407

T

Tappet, 30
 Temperature, atmospheric, 451
 coefficient, 78
 effect on power, 101, 105
 hot day, 414, 456
 induction system, 351
 installation, allowable, 410, 411
 mean gas, 157
 (See also Coolant; Cylinder
 head; Oil inlet temperature)
 Test club, 262
 Test stands, 262
 cable, 263
 dynamometer, 264
 equipment, 268
 operation, 275
 power recovery, 266
 Tests, engine, 259
 endurance, 261

- Tests, engine, final, 259
 green run, 259
 penalty, 260
 run-in, 259
 single cylinder, 262
 take-off, 261
 type, 5, 261
 Tests, flight, 408
 fuel, 205, 213
 installation, 408
 oil, 217
 spark plug, 153, 154
 vibration, 189, 914
 Thermal efficiency, 56
 Timing, magneto, 146
 spark, 47
 effects, 41, 110
 valve, 46, 51, 110
 Timing circle, 46
 Torching, 279
 Torque, harmonic components, 185
 variation, 184
 Torque meter, 401
 Torsional vibration, 173
 cause, 183
 dampers, 186
 isolation, 302
 Tower shaft, 40
 Transfer tube, propeller oil, 35
 Trimethyl pentane, 200
 Trouble shooting, 154, 278
 True-motion connecting rods, 182
 Turbosuperchargers, exhaust, 99,
 362
 installation, 363
 Type test, 5, 261
- U
- Unbalance, dynamic, 179
 mass, 188
 propeller, 188
 static, 179
 Unsaturated hydrocarbons, 200
- V
- Valve, corrosion, 247
 operating temperatures, 28
 poppet, 12, 27
 sleeve, 12, 29
 Valve clearance, 36
 Valve floating, 87
 Valve guide, 26
 bellmouthing, 254
 Valve overlap, 46, 110.
 Valve seat, 26
 Valve springs, 29
 Valve timing, 46, 51, 110
 Vapor lock, 371, 375
 Vapor separators, 130, 133, 376
 Varnish, 254
 Velocity enrichment, 117
 Vents, fuel tank, 380
 oil system, 395
 Vibration, 172
 aircraft, 178, 301
 amplitude of, 178
 crankshaft, 175
 damping, 172, 186
 degrees of freedom, 175
 engine, 191
 engine mount, 301
 exciting forces, 178
 engine, 178, 186
 propeller, 188
 forced, 177
 free, 173
 harmonics, 175, 191
 human sensitivity, 301
 isolation, 301
 mode, 174, 186
 natural frequency, 172
 node, 175
 period of, 172
 pick-ups, 189, 194
 propeller, 192
 test equipment, 189, 194
 tests, 191
 Viscosimeter, 218
 Viscosity, 217
 effect of, on lubrication, 228
 Viscosity index, 219
 Volatility, fuel, 213
 Volumetric efficiency, 56
- W
- Water brake, 272, 274
 Wear, 244
 Wright engines, 11, 21, 26, 34, 234